

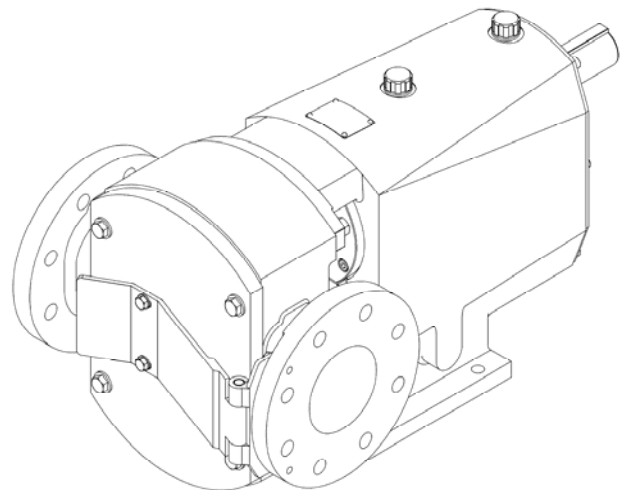

Series D

Ductile Iron Positive Displacement Rotary Lobe Pumps

Operating Manual



EC Declaration of Incorporation

The designating company

Alfa Laval Eastbourne, Alfa Laval Limited
Company Name

Birch Road, Eastbourne, East Sussex BN23 6 PQ
Address

Phone: (01323) 412555 Fax: (01323) 412515
Phone and Fax No.

We hereby declare that the following machinery conforms to the machinery directive 98/37/EC and to the following other relevant directives. The machinery has been designed and manufactured in accordance with the transposed harmonised European standards; European and national standards as listed:

Machine Description: Rotary Lobe Pump
Type/Size: _____ Serial Number: _____
Date of Manufacture: _____

This machinery has been designed and manufactured in accordance with the following transposed harmonised European Standards:

EN809: 1998 Pumps and pump unit for liquids - common safety requirements
ISO9001: 2000 Quality Management System

A technical construction file for this machinery is retained at the above address.

Signed:  Date: _____
P.Sweet _____ Quality/H&S Manager _____



EC Declaration of Conformity

The designating company

Alfa Laval Eastbourne, Alfa Laval Limited
Company Name

Birch Road, Eastbourne, East Sussex BN23 6 PQ
Address

Phone: (01323) 412555 Fax: (01323) 412515
Phone and Fax No.

We hereby declare that the following machinery conforms to the machinery directive 98/37/EC and to the following other relevant directives. The machinery has been designed and manufactured in accordance with the transposed harmonised European standards; European and national standards as listed:

Machine Description: **Rotary Lobe Pump - Motorised**

Type/Size: _____ Serial Number: _____
Date of Manufacture: _____
Other Applicable Directives: **Electrical Equipment Low Voltage 73/23/EEC**

Electromagnetic Compatibility 89/336/EEC

This machinery has been designed and manufactured in accordance with the following transposed harmonised European Standards:

EN809: 1998 Pumps and pump unit for liquids - common safety requirements

ISO9001: 2000 Quality Management System

A technical construction file for this machinery is retained at the above address.

Signed: *P. Sweet* _____ Date: _____
P.Sweet _____ **Quality/H&S Manager** _____



Contents

	Page No
1.0 General	
1.1 Pump Limits of Application or Use	1
1.2 Duty Conditions	1
1.3 Noise Levels	1
1.4 Utility Requirements	1
1.5 Safety Precautions	2
1.6 Health and Safety Information	3
2.0 Unpacking, Handling and Storage	
2.1 Documents	4
2.2 Unpacking	4
2.3 Handling	4
2.4 Pump Storage	5
3.0 Description of Pump or Pump Unit	
3.1 General Pump Description	6
3.2 Principle of Operation	6
3.3 Pump Dimensions	7
3.4 Pump and Pump Unit Weights	8
3.5 Pump Displacement and Capacities	9
4.0 System Design and Installation	
4.1 System Design Advice	10
4.2 Pump and Base Foundations	11
4.3 Installation	11
4.4 Coupling Misalignment	12
4.5 Pulley Belt Tension Adjustment	13
4.6 Pipework	14
5.0 Commissioning	
5.1 Recommended Lubricants	15
5.2 Lubricating the Pump	15
5.3 Flushed Seal Arrangements	16
5.4 Connecting the Flush	16
5.5 Flushing Pipework Layout	17
5.6 Flushed Seal Housing Connections	18
5.7 Flushing Fluid	18
5.8 Flushing Pressure and Flow Rate	18

Contents

	Page No
6.0 Start up, Shut Down and Cleaning in Place	
6.1 Start up Checklist	19
6.2 Pump Shut Down Procedure	20
6.3 Direction of Rotation	20
7.0 Maintenance and Inspection	
7.1 Maintenance Schedule	21
7.2 Recommended Spare Parts	21
7.3 Urethane Rotors	21
7.4 Maintenance Tools	22
8.0 Rotor Retention	
8.1 Torque Locking Assembly - Mounting Instructions	23
8.2 Torque Locking Assembly - Release Instructions	23
8.3 Rotor Retention - Torque Locking Assembly	24
9.0 General Maintenance	
9.1 Before Dismantling the Pump	25
9.2 Removing the Rotors	26
9.3 Removing the Rotorcase	27
9.4 Replacing the Front Gearcase Seals	28
9.5 Fitting and Shimming the Rotorcase	29
9.6 Front Cover Reversal	29
9.7 Removal of Rear Gearcase Cover and Replacement of Seals	30
9.8 Refitting the Rotors	30
9.9 Wearplates	31
10.0 Gearbox Components	
10.1 Timing Gears	
10.2 Timing Adjustment	32
10.3 Timing Gear Removal	33
10.4 Lipseal - Removal and Fitting	33
10.5 Fitting the Timing Gears	33
10.6 Shaft Removal	33
10.7 Bearings General	34
10.8 Bearings Removal	34
10.9 Fitting Bearings to the Shaft	34
10.10 Shaft Replacement	34
	35

Contents

	Page No
11.0 Product Seal, Removals and Fittings	
11.1 Single Mechanical Seal	36
11.2 Single Flushed Mechanical Seal	37
11.3 Double Mechanical Seal	38
11.4 Packed Gland	39
11.5 Packed Gland with Flush	40
11.6 Cartridge Mechanical Seal	41
12.0 Faults, Causes and Remedies	42
13.0 Technical Data	
13.1 Pump Information Chart	43
13.2 Seal Specification Chart	43
13.3 Torque Specification Chart	44
14.0 Exploded Drawings and Parts List	
14.1 Priming Adaptor Ports	45
14.2 D4 Pump	46
14.1 D5 Pump	48
14.2 D6 Pump	50

Operating Manual

1.0 General

1.1 Pump Limits of Application or Use

This range of pumps has been designed to offer a wide span of transfer duties throughout industry where the use of stainless steel for pumphead components is not essential.

Pressures of up to 15 bar, speeds to 750rpm and temperatures to 200°C can be obtained on this range of pumps depending on pump model/size. These conditions cannot always be obtained simultaneously. The model type/size will be shown on the nameplate positioned on the pump.

The pump/pump unit will have been selected from the pump users specific application when known and the pump serial number will relate to this.

If the user has not specified the pumping application or needs to change it, it is important to confirm that the materials of construction and product seals are compatible with the pumping application and that adequate NPSH is available

It is therefore strongly recommended that the user contact the supplier quoting :- pump model/size, serial number and system details (e.g. product, pressure, flow rate).

1.2 Pump Duty Conditions

The pump should only be used for the duty for which it has been specified. The operating pressure, speed and temperature limits have been selected at the time of order and MUST NOT be exceeded for the pump. These details are stated on the original documentation and if not available may be obtained from your supplier quoting :- pump model and serial number.

1.3 Noise Levels

Under certain operating conditions pumps and / or drives and / or the systems within which they are installed can produce sound pressure levels in excess of 85dB [A]. When necessary personal protection against noise should be taken to safeguard the hearing of persons who are likely to be in close proximity to the equipment.

Please contact SSP Pumps for further information if necessary.

1.4 Utility Requirements

Electrical Supply :-

This pump may be supplied bare shaft or coupled to a drive unit for which a drive unit/electrical supply will be required.

Note : The pump may be also driven by a diesel drive unit.

Water Supply :-

Additional water supplies may be required if the pump is fitted with a product seal flushing arrangement. Consult your supplier for flush fluids compatible with products pumped.

1.5 Safety Precautions

All warnings in this manual are summarised on this page.

Pay special attention to the instructions below so that severe personal injury or damage to the pump can be avoided.

Personnel performing installation, operation and maintenance of the pump must have the relevant experience required.

Warning Signs :



General safety instructions are preceded by this symbol.



Electrical safety instructions are preceded by this symbol.



Take great care when using caustic agents.

Installation



: **Always** observe the technical data.



: The pump **must** be electrically connected by authorised personnel. (See the motor instructions supplied with the drive unit).



: **Never** start in the wrong direction of rotation with liquid in the pump.



: **Never** put your hands or fingers inside the port connections

Operation



: **Always** observe the technical data.



: **Never** touch the pump or the pipelines when pumping hot liquids.



: **Never** stand on the pump or pipelines.



: **Never** run the pump with the suction side or the pressure side blocked.



: **Always** handle toxic and acidic liquids with great care.



: **Never** put your hands or fingers inside the port connections.



: In certain circumstances the gearbox and pump may become very hot. **Never** touch the pump without wearing protective clothing

Maintenance



: **Always** observe the technical data.



: **Always** disconnect the pump from the drive unit and power supply when servicing the pump.



: The pump must **never** be hot when servicing it.



: The pump and pipelines must **never** be pressurised when servicing the pump.



: **Never** put your hands or fingers inside the port connections.

Study this manual carefully

Operating Manual

1.6 Health and Safety Information

Potential Safety Hazards

The following section gives information on handling, storage and disposal of parts and materials used in the pumps which may be considered hazardous to health.

Please pass this information on to your Safety Officer, he may need it to comply with Health and Safety, and COSHH regulations.

Electric motors - the pump may have an electric motor fitted, ensure that the relevant fire equipment is available.

The information contained here is brief.

General First Aid

If potentially hazardous substances are accidentally inhaled, or skin or eyes contaminated, then the following basic precautions should be taken

- Inhalation - Remove to fresh air
- Skin - Wash with soap and water
- Eyes - Flush with water, seek medical attention

In all cases, if symptoms persist, seek medical attention.

Material	Use	Major Hazard
SILICON SEALANT	GEARBOX SEAL RETAINERS, REAR COVER, GENERAL SEALANT.	RELEASES VAPOUR AT ROOM TEMPERATURE.
SEALANT (RED HERMETITE)	GEARBOX SEAL RETAINERS, REAR COVER, GENERAL SEALANT.	RELEASES VAPOUR AT ROOM TEMPERATURE, HIGHLY FLAMMABLE, TREAT AS FIRE HAZARD.
ANTI-SEIZE COMPOUNDS	BEARINGS	APPLIED FROM AEROSOL. RELEASES VAPOUR. DISPOSE OF CONTAINER AS IF PRESSURISED.
ADHESIVES (E.G. PERMABOND)	BEARING NUTS, ADJUSTMENT NUTS.	RELEASES VAPOUR AT ROOM TEMPERATURE.
OIL AND GREASE	OIL - GENERAL LUBRICATION GREASE - PRODUCT SEALS, TIMING GEARS, GENERAL LUBRICATION.	SKIN AND EYE IRRITANT.
PLASTIC COMPOUNDS (PTFE, POLYPROPYLENE, PVC)	PTFE - 'O' RINGS, LIP SEALS, GLAND PACKING. POLYPROPYLENE - GLAND GUARDS. PVC - GLAND GUARDS.	RELEASES FUMES WHEN HEATED.
ELASTOMERIC COMPOUNDS (EP, VITON, NITRILE, NEOPRENE)	ALL - 'O' RINGS, LIP SEALS. NITRILE, POLYURETHANE - ROTORS (KNOWN AS RUBBER AND URETHANE).	RELEASES FUMES WHEN HEATED.
ARAMID FIBRE	GLAND PACKING.	EMMITS HARMFUL DUST. RELEASES FUMES WHEN HEATED.
PAINT	EXTERNAL PUMP SURFACES.	RELEASES DUST AND FUMES IF MACHINED. TREAT AS A FIRE HAZARD.

2.0 Unpacking, Handling and Storage

To avoid any problems, on receipt of your pump always use the following procedure:-

2.1 Documents

1. Check the delivery note against the goods received.
2. If the pump has been delivered with an electric motor check that the motor instructions are available.

2.2 Unpacking

Care must be taken when unpacking the pump, and the following stages must be completed:-

1. Inspect the packing for any possible signs of damage in transit.
2. Carefully remove the packing away from the pump.
3. Inspect the pump for any visible signs of damage.
4. Clean away the packing from the pump port connections.
5. Ensure that any additional equipment such as seal flushing pipework is not damaged.

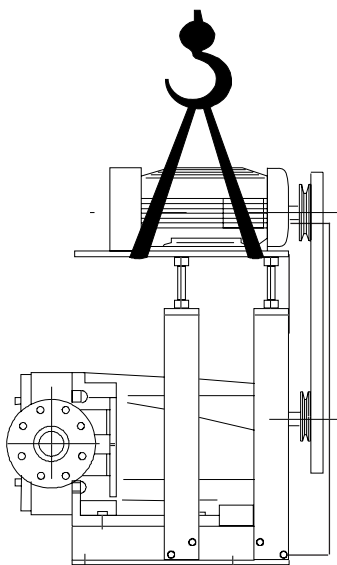

Pump Pedestal Mounted

2.3 Handling

Refer to the pump weights guide, prior to using any lifting gear. Use the correct lifting slings for the pump weight (or pump and drive if applicable).

The following details show how the pumps should be lifted.

Bareshaft Pump :- the slings should be wrapped around the ports and the drive shaft.

Pump with in-line Drive Unit:- the slings should be positioned around the pump rotorcase and under the motor.

Note :- To stop the slings slipping always cross the slings on the lifting hooks.

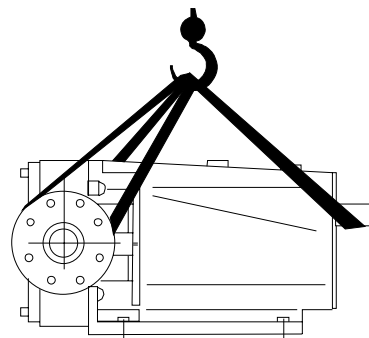

Bareshaft Pump

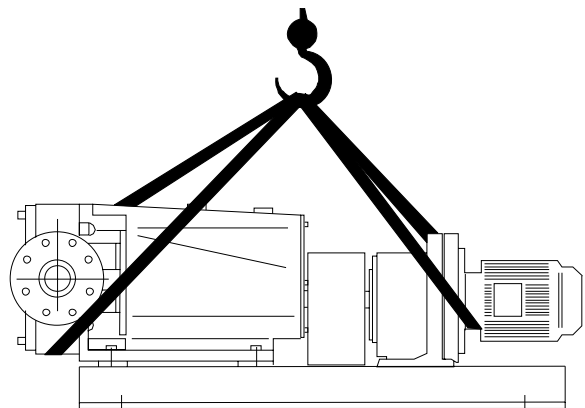

Pump with in-line Drive Unit

Operating Manual

2.4 Pump Storage

After receipt and inspection if the pump is not to be installed immediately the pump should be repacked and placed in suitable storage. The following points should be noted:-

1. Plastic or gasket type port covers should be left in place.
2. Pumps received wrapped with corrosion inhibiting treatment material should be rewrapped.
3. A clean, dry, vibration free location should be selected. If stored in a moist atmosphere, further protect the pump or unit with a moisture repellent cover until it is to be installed.
4. Rotate pump/pump unit by hand, weekly, to prevent bearing and gear damage.
5. All associated ancillary equipment should be treated similarly.
6. If the pump is fitted with a diesel/petrol engine it is advisable to disconnect the pump and run the engine every two months.

Operating Manual

3.0 Description of Pump or Pump Unit

3.1 General Pump Description

The pump supplied is a positive displacement pump, which may be supplied with or without a drive unit (see below). The drawing below indicates various parts of the pump.

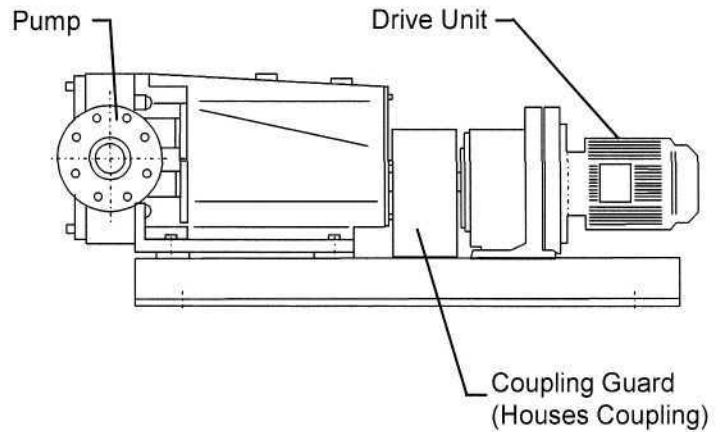
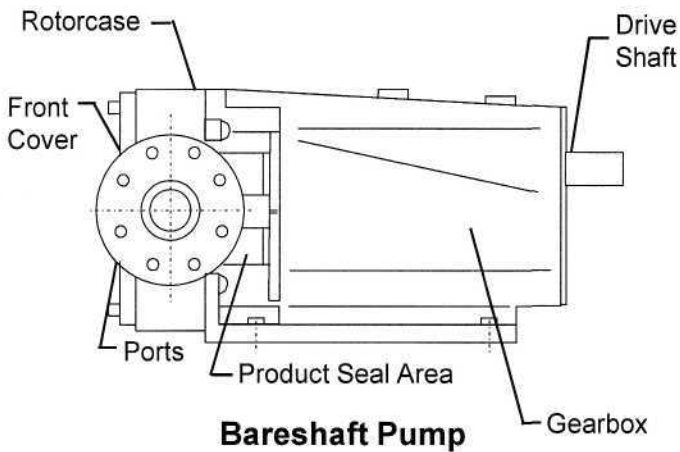

3.2 Principle of Operation

The rotors are timed such that when they rotate no contact occurs. The direction of flow is reversed by changing the direction of rotation of the pump drive shaft. The pumping principle is as follows :

The rotors have just come out of mesh creating a reduction in pressure in the chamber which is then filled with product.

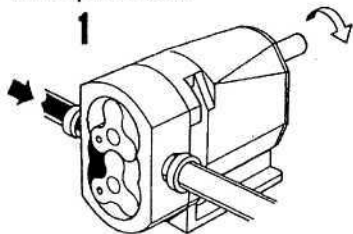

The product is contained in the rotorcase chamber.

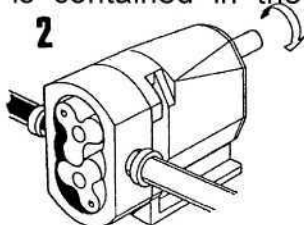

As the rotors continue to rotate the product is transferred around the outside of the rotorcase to the discharge side.

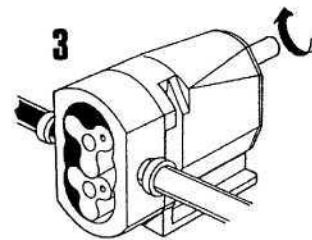

The rotors lobes go into mesh and the product is discharged from the pump.

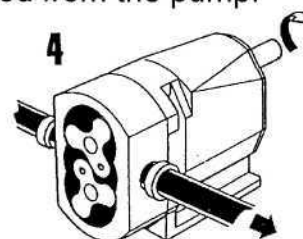

Operating Manual

3.3 Pump Dimensions

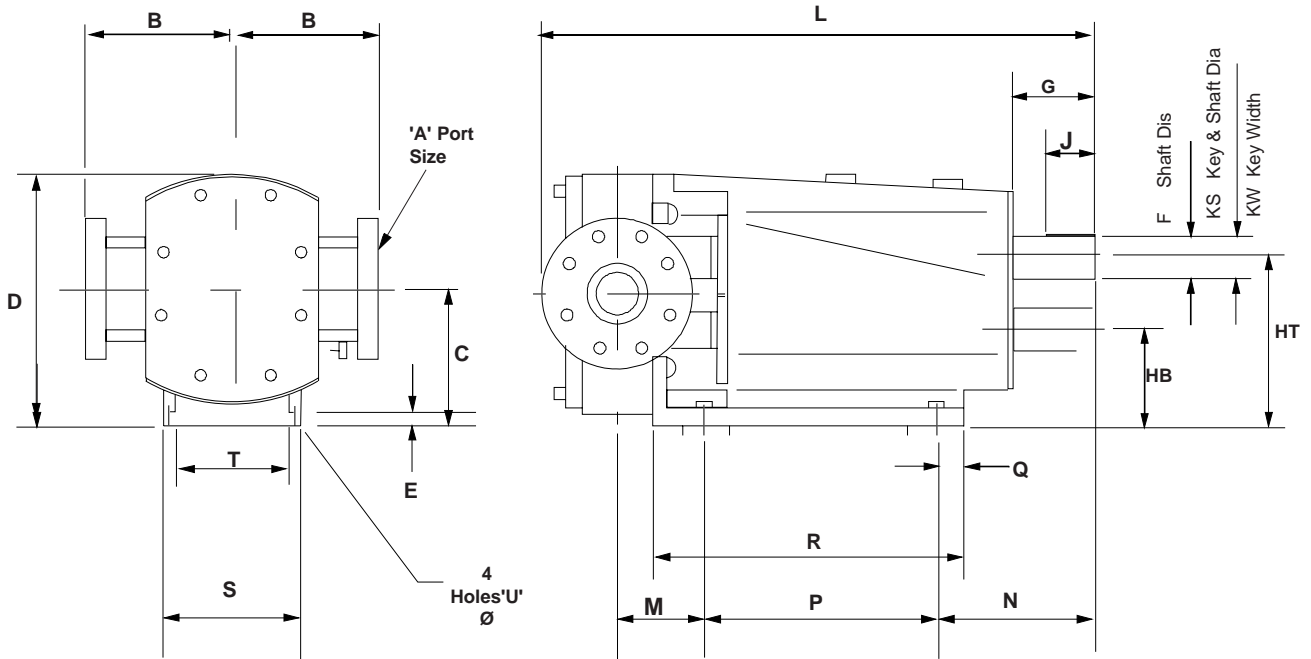

All dimensions in mm

PUMP MODEL	A	B	C	D	E	F	G	HB	HT	J	KS	KW	L	M	N	P	Q	R	S	T	U
D4-0095	75	170	163	307	20	38	80	115	211	63	41	10	597	122	225	150	35	255	184	150	14
		520*	338*																		
D4-0140	100	170	163	307	20	38	80	115	211	63	41	10	628	138	225	150	35	255	184	150	14
		530*	338*																		
D5-0200	100	190	195	371	20	45	110	135	255	70	48.5	14	699	125	279	180	35	275	210	180	14
		550*	315*																		
D5-0290	100	190	195	371	20	45	110	135	255	70	48.5	14	719	145	279	180	35	275	210	180	14
		550*	315*																		
D5-0290	150	190	195	371	20	45	110	135	255	70	48.5	14	747	145	279	180	35	275	210	180	14
D6-0420	150	225	225	429	20	48	110	155	295	70	51.5	14	832	163	266	260	40	370	220	190	14
D6-0600	150	225	225	429	20	48	110	155	295	70	51.5	14	857	188	266	260	40	370	220	190	14

* = Dimensions when priming adaptors are fitted

The above dimensions are for guidance only and should not be used for installation purposes. Certified dimensions are available upon request.

3.4 Pump and Pump Unit Weights

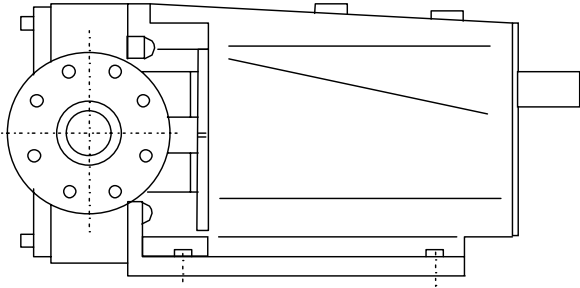

Bareshaft Pump

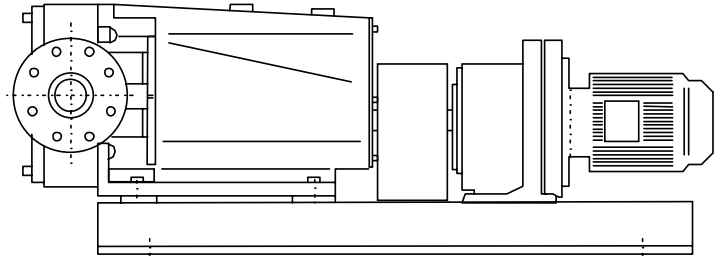

Pump Unit - Pump complete with Drive Unit

Pump Model	Bareshaft Pump KG	Pump with Drive Unit KG
D4-0079	110	147
D4-0095	113	150
D4-0140	130	220
D5-0168	170	264
D5-0200	176	270
D5-0290	192	350
D6-0353	281	392
D6-0420	289	400
D6-0600	300	530

The above weights are for guidance only and will vary depending upon the specification of the pump, baseplate and drive unit.

Operating Manual

3.5 Pump Displacement and Capacities

The following table details the pump capacities for the pump models. This figure will change depending upon speed, pressure, temperature and product being pumped.

Pump Ref	Displacement litres/rev	Maximum Speed Water (rpm)	Maximum Capacity at Maximum Speed m³/hr
D4-0079	0.79	750	35.6
D4-0095	0.95	500	28.5
D4-0140	1.40	500	42.0
D5-0168	1.68	600	60.5
D5-0200	2.00	500	60.0
D5-0290	2.90	500	87.0
D6-0353	3.53	500	106.0
D6-0420	4.20	500	126.0
D6-0600	6.00	500	180.0

Operating Manual

4.0 System Design and Installation

4.1 System Design Advice

When designing the pumping system :-

- Do** - confirm with the supplier the Net Positive Suction Head (NPSH) requirements for the pump, as this is crucial for ensuring the smooth operation of the pump and preventing cavitation.
- Do** - avoid suction lifts and manifold/common suction lines for two pumps running in parallel, as this may cause vibration or cavitation.

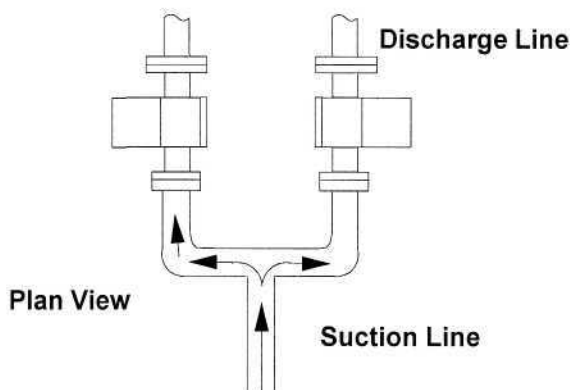

- Do** - protect the pump against blockage from hard solid objects e.g. nuts, bolts etc. Also protect the pump from accidental operation against a closed valve by using one of the following methods :- relief valves, pressure switch, current monitoring device.
- Do** - Install a motor current sensing device which automatically reverses the pump when an overload or jam is detected.

Note : This is not recommended when non return valves are fitted.

- Do** - fit suction and discharge pressure gauges to monitor pressures for diagnostic purposes.
- Do** - install non-return valve to prevent turbinng when high pressures are applied to the pump whilst it is not in use. Valves are also recommended if two pumps are to be used on manifold/common discharge lines.
- Do** - make the necessary piping arrangements if flushing is required for the seal.
- Do** - provide a hose cleaning facility to assist maintenance, ensuring the drive unit meets the specification for hose cleaning.

Operating Manual

4.2 Pump and Base Foundations

Depending on your requirements the pump and drive (if supplied) may arrive mounted on a baseplate. Our standard baseplates have pre-drilled fixing holes to accept base retaining bolts.

To provide a permanent, rigid support for securing the pump unit a foundation is required, this will also absorb vibration, strain or shock on the pumping unit.

Foundation Size

The foundation should be approximately 150mm longer and wider than the mounting base of the unit. The depth of the foundation should be proportional to the size of the pump unit (pump complete with drive and baseplate). For example, a large pump unit foundation depth should be at least 20 times the diameter of the foundation bolts.

Bolt Location Dimensions

The location and sizes of the relevant bolting down holes can be provided on a certified drawing from your supplier.

Typical Foundations Bolts

The drawing below shows two methods for foundation bolt retaining. The sleeve allows for 'slight' lateral movement of the bolts after the foundation is poured. Use rag or paper to prevent the concrete from entering the sleeve while the foundation is poured. A minimum of 14 days is required to allow the curing of the concrete prior to operation.

D = Diameter of foundation bolts

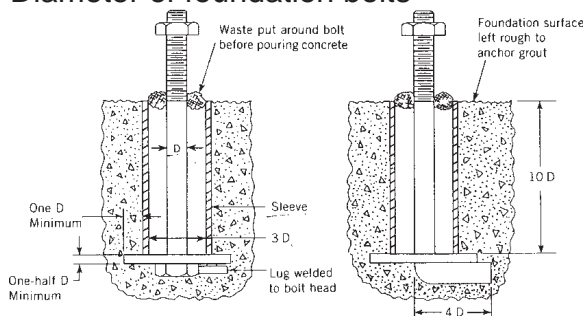

4.3 Installation

Before the pump is installed it is advisable to consider the following:

Always - Ensure that the mounting surface is flat to avoid distortion of the baseplate. This will cause pump/motor shaft misalignment and pump/motor unit damage.

Check - **pump shaft to motor shaft alignment** once the baseplate has been secured and adjust as necessary.

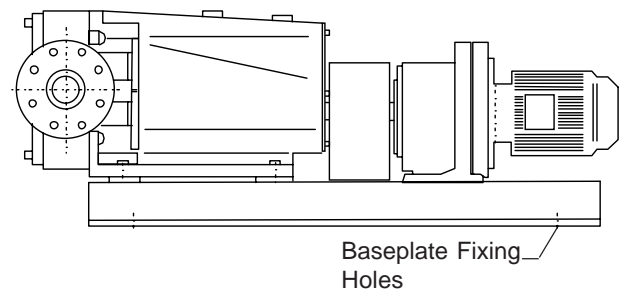

Note : Always allow at least one metre for pump access/maintenance all around the pump.

Weight - Consider the weight of the pump, drive and lifting gear requirements.

Electrical Supply - Ensure that there is an adequate electrical supply close to the pump drive unit. This should be compatible with the electric motor selected.

4.4 Coupling Misalignment

When installing the pump and drive unit, it is **essential** to ensure that the coupling is **not** twisted during installation. The main cause of misalignment is by fitting the baseplate to an uneven surface.

Check the maximum angular and parallel allowable misalignments for the couplings before operating the pump.

Parallel Misalignment

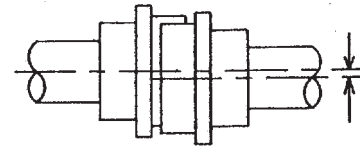

Angular Misalignment

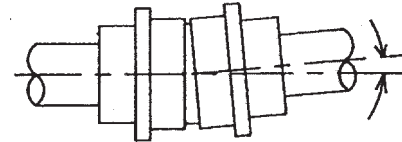

Coupling Type	Recommended Maximum Parallel Misalignment		Maximum Angular Misalignment
	Size	mm	Degrees
David Brown Nylicon Flexible	1	0.2	± 1.5° (Per Gear in Mesh)
	2	0.3	
	3	0.4	
William Kenyon Flexilok	FL63	0.25	0.75°
	FL80		
	FL112	0.3	1.0°
	FL125	0.4	
	FL160	0.5	
Fenaflex Flexible Tyres	F40	1.1	4°
	F50	1.3	
	F60	1.6	
	F70	1.9	
	F80	2.1	
	F90	2.4	

Note : The above table indicates the common coupling types used on the pump ranges. Details for other coupling types will be available on request.

Operating Manual

4.5 Pulley Belt Tension Adjustment

An **incorrectly tensioned belt** will cause belt slip and short belt life. An **excessively tensioned belt** will overload both belts and bearings. **Always use a belt tension gauge** fo setting up.

Isolate the drive unit and pump from all power and control supplies before attempting to work on adjusting the belts.

1. Measure the span length.
2. Calculate the required deflection: ('x')
 100mm span length = 1mm deflection
 therefore :
 400mm span length = 4mm deflection
3. Refer to the table for recommended minimum and maximum deflection force for small pulley diameter range.

To convert Newtons to **pounds force** multiply by 0.2248.

To convert Newtons to **kilogrammes force** multiply by 0.1020.

4. Use a belt tension gauge with the figures to determine the belt adjustment required.
5. Belt tension adjustment is achieved by adjusting the nuts on the pedestal frame.
6. Finally check that all nuts are re-tightened and the belts can move 'freely' by hand (depending upon pump size and system design).
7. Ensure the pulleys are kept vertically and horizontally to each other and aligned as per diagrams (A) and (B).

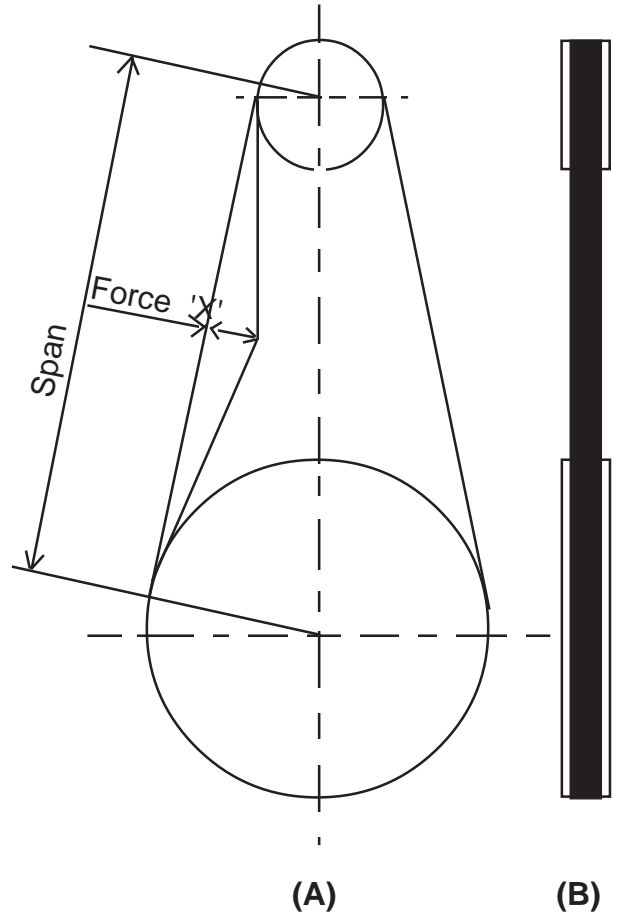

Belt Section	Small Pulley Diameter Range	Recommended Deflection Force Newtons	
		min	max
XPZ SPZ	56	7	11
	60-63	8	13
	67-71	9	14
	75-80	10	15
	85-95	11	16
	100-125 132-180	13 16	19 24
XPA SPA	80-125	18	27
	132-200	22	31

Note : The above table indicates the common pulley types used on the pump ranges. Details for other pulley types will be available on request.

4.6 Pipework

All pipework **must** be supported. The pump **must not** be allowed to support any of the pipework weight.

Remember - Pipework supports must also support the weight of the product being pumped.

Always :-

Have - Short straight suction lines to reduce friction losses in the pipework thereby improving the NPSH available.

Use - Long radius bends wherever possible.

Provide - Isolating valves on each side of the pump to isolate the pump when necessary.

Keep - Pipework horizontal where applicable to reduce air locks. Include eccentric reducers on suction lines.

Check - Coupling alignment during installation to highlight pipework alignment/support problems.

Install - A liquid trap around to pump to assist in priming. (See below)

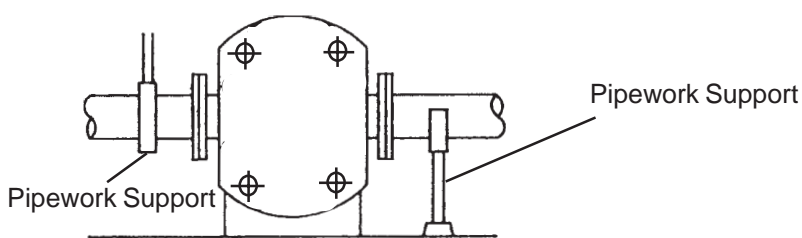
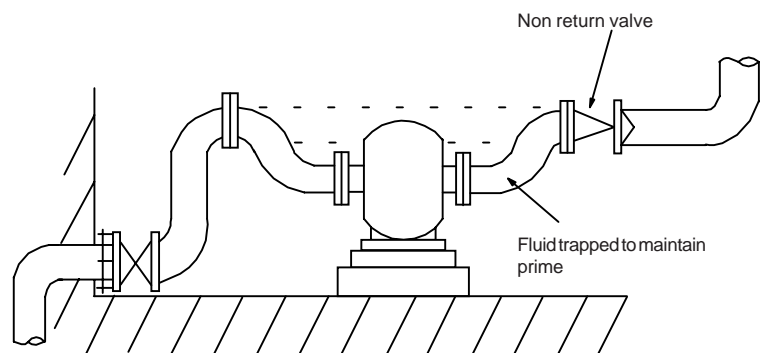

Operating Manual

5.0 Commissioning

5.1 Recommended Lubricants

Pumps specified oil filled :-

The pump will **not** be supplied with oil therefore the table below must be used to select a recommended oil.

Oil Filled
-20° C to +130° C
BP Energol GR - XP150 Castrol Alpha SP150 Mobil Gear 629 Shell Omala 150 Texaco Meropa 150 Esso Spartan EP150

5.2 Lubricating the Pump

Changing the Oil :-

First change - After 150 hours of operation.

Next change - Every 3000 hours of operation.

Only use the oil types recommended by your supplier.

Oil Filling -

Fill with oil through the filler plug to the level indicated in the sight glass.

Pump Model	Top Chamber Litres	Bottom Chamber Litres	Total
D4	0.35	0.75	1.10
D5	0.62	1.38	2.00
D6	1.30	2.30	3.60

Note : Ensure all ancillary drive units are lubricated according to the manufacturers instructions.

5.3 Flushed Seal Arrangements

A flushed seal arrangement is fitted in order to cool the seal area.

It is **important** that:-

- The flush is correctly **connected**. (See overleaf).
- A **compatible** flushing **fluid** is used.
- The fluid is supplied at the **correct pressure** and **flow** rate.
- The flush is **turned on** at the **same time/ prior to starting** the pump, and turned off at the same time/after stopping the pump.

5.4 Connecting the Flush

The following equipment is **strongly recommended** when using a flushing system.

- **Control valve** and **pressure gauge**, to enable the correct flushing pressure to be obtained and monitored. (A constant flow valve can be used).
- **Isolation valve** and **check valve**, so that the flush can be turned off, and to stop any unwanted substances flowing in the wrong direction.
- A method of visibly indicating flushing fluid flow e.g. using a **tun dish**.

Operating Manual

5.5 Flushing Pipework Layout

This suggested arrangement is for **single mechanical seals**. If the pump is fitted with **double mechanical seals** or **packed glands** the **pressure gauges** and **control valves** should be fitted on the **outlet side** of the system.

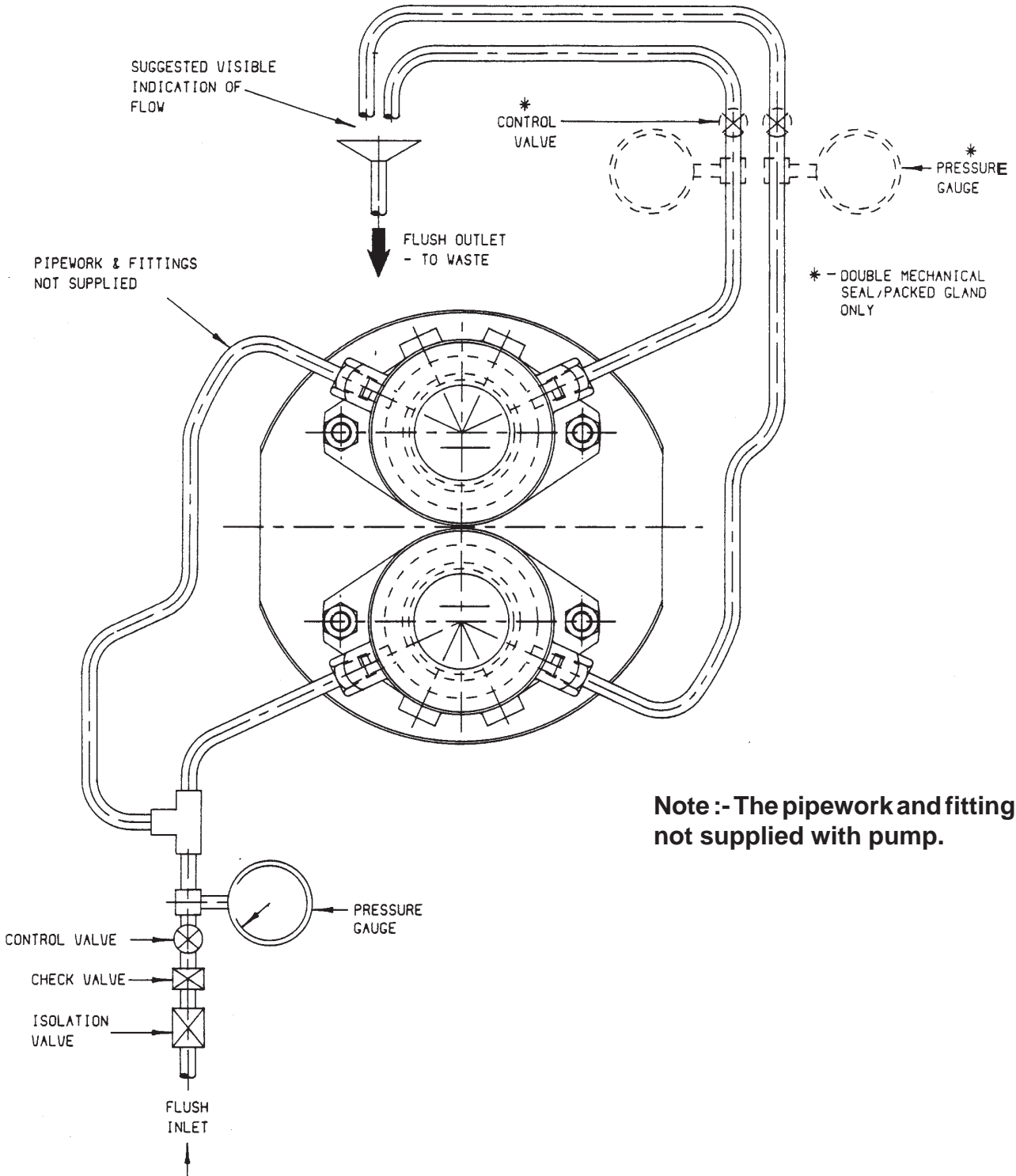

Note :- The pipework and fittings are not supplied with pump.

5.6 Flushed Seal Housing Connections

Pump Model	Single/Double Mech. Seal	Packed Gland
D4	1/8"	1/4"
D5	1/8"	1/4"
D6	1/8"	1/4"

All connections BSPT or NPT as specified at the time of order.

5.7 Flushing Fluid

The choice of flushing fluid is dependant upon the pumping media and duty conditions i.e. pressure and temperature. Usually water is used for cooling or flushing water soluble products. For advice on selecting a suitable flushing fluid please contact the supplier.

5.8 Flushing Pressure and Flow Rate

Single Mechanical Seal - 0.5 Bar maximum. Any further increase in pressure will result in lip seal failure.

Double Mechanical Seal/Packed Gland Seal
 - 1.0 bar higher pressure compared to the discharge pressure of the pump. If the discharge pressure fluctuates set the flushing pressure to suit the maximum condition.

For guidance the pressure at the seal is approximately $\frac{2}{3}$ of the pumping pressure.

The flushing **flow rate** must be adequate to ensure that the temperature limitation of the seals is not exceeded. Contact your supplier for further information on the recommended flow rate for the product seal fitted.

Operating Manual

6.0 Start up, Shut Down and Cleaning in Place

6.1 Pump Start-up Checklist	Yes	No
1. Is the location of the 'stop' button clear?	<input type="checkbox"/>	<input type="checkbox"/>
2. Has the pipework system been flushed through to purge welding slag and any other hard solids?	<input type="checkbox"/>	<input type="checkbox"/>
3. Have all obstructions been removed from the pipework or pump?	<input type="checkbox"/>	<input type="checkbox"/>
4. Are the pump connections and pipework joints tight and leak-free ?	<input type="checkbox"/>	<input type="checkbox"/>
5. Is there lubrication in the pump and drive unit?	<input type="checkbox"/>	<input type="checkbox"/>
6. If your product seals require flushing has the flushing supply been fitted?	<input type="checkbox"/>	<input type="checkbox"/>
7. Are the pipework valves open ?	<input type="checkbox"/>	<input type="checkbox"/>
8. Are all safety guards in place?	<input type="checkbox"/>	<input type="checkbox"/>
9. Start then stop the pump, is the product flowing in the correct direction ?	<input type="checkbox"/>	<input type="checkbox"/>
10. Are the pump speed/pressure settings below the pump maximum limitations?	<input type="checkbox"/>	<input type="checkbox"/>

All answers should be 'Yes' before proceeding.

If there are any pumping problems refer to the fault finding chart.

6.2 Pump Shut Down Procedure

1. Turn the pump off.
2. Isolate the pump/drive unit from all power and control supplies.
3. Close the pipework valves to isolate the pump.
4. If the pump is to be dismantled refer to the dismantling section.

6.3 Direction of Rotation

The direction of flow is dictated by the direction of rotation of the drive shaft. Reversing the direction of rotation will reverse the flow direction. Top and bottom shaft drive pumps have opposite flow directions as illustrated.

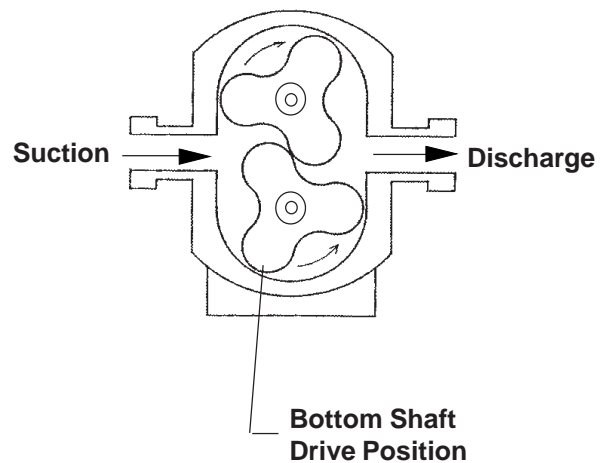
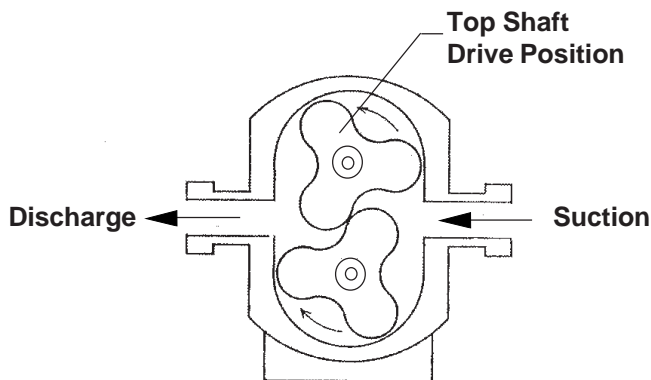

Operating Manual

7.0 Maintenance and Inspection

7.1 Maintenance and Schedule

It is advisable to install pressure gauges either side of pump so that any problems within the pump/pipework will be highlighted.

Your weekly schedule should include:

- Checking the **oil level** in the gearcase
- Checking the **mechanical seals** for leakage and replacing as necessary.
- Geasing the mechanical sewage seal (if fitted).
- Adjusting the **packed glands** to control leakage.
- Checking the **oil seals** for leakage.
- Check **pumping pressures**.

7.2 Recommended Spare Parts

The following table details the recommended spare parts which should be retained within your maintenance stock.

Part Description	Quantity
Lip Seal Drive End	2
'O' Ring Front Cover	1
Lip Seal Gland End	2
Rotors	2
'O' Ring Rotor Sealing	2
'O' Ring Rotor Cap	2
Product Seals	2

7.3 Urethane Rotors

For pumps fitted with urethane covered rotors, please ensure that the rotors are not left immersed in pumped media inside the pump head for long periods (20 days max), without the pump being used or rotated.

Failure to adhere to this could lead to rotor swelling, thereby causing possible rotor jamming in the pump head and poor pump performance. It should be noted that urethane rotors should not be allowed to come into any contact with any hydrocarbons, ketones or ethers, as these products will cause rotors to swell.

7.4 Maintenance Tools

Dismantling and Assembly of the Pumphead

You will need - Allen keys
Spanners
Socket set
Wooden wedge
Soft mallet
Cleaning hose
Silicon grease
Torque wrench
Rotor clamp tool (supplied with pump)

Dismantling and Assembly of the Gearbox

You will need - A Work Shop equipped with:

- A heavy duty vice
- A press and pressing tools
- Lifting gear
- Induction heater
- A method of lubrication collection
- Lever soft ended
- Wooden wedge
- 'C' spanner
- Liquid gasket
- Permabond 145 (or equivalent)
- Torque wrench

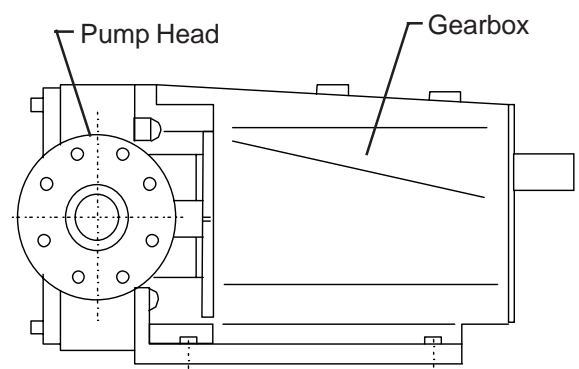

Operating Manual

8.0 Disassembly

Rotor retention on all pumps in the Series D range is by Torque Locking Assembly (TLA) with flush fitting rotor caps. The rotor spline area is sealed with three O'rings per rotor (A, B, & C), one (A) between the shaft and rotor, and two (B & C) seated in the rotor cap. The rotor caps are retained by socket head cap screws. The TLA's should be tightened to the recommended torque values.

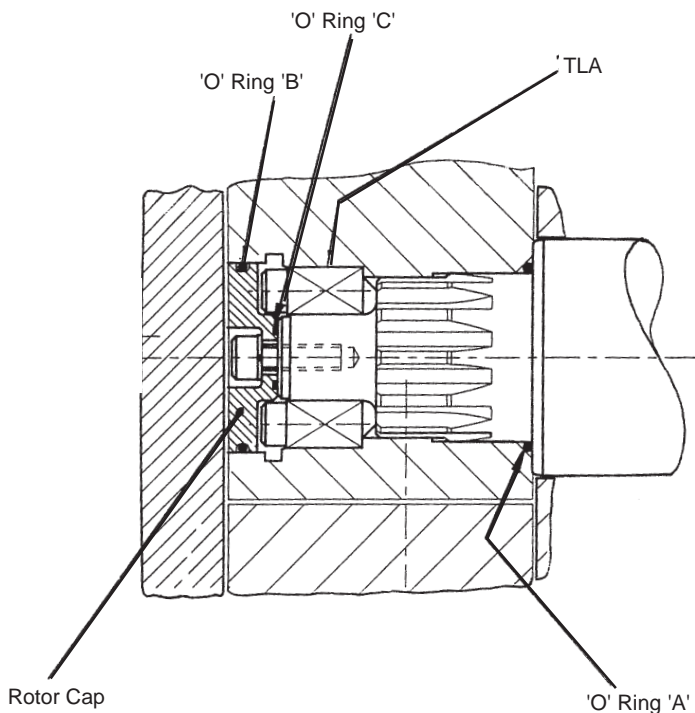

Note : 'O' ring 'A' is fitted in a recess on pumps D5 and D6.

8.1 TLA Mounting Instructions

When fitting a TLA it is recommended that :-

1. The TLA is lightly oiled on all surfaces to assist in achieving the correct torque value and to aid its release when removing.
2. Once fitted into its working position and before tightening, a temporary rotor clamp, supplied with the pump, should be used to ensure the rotor with TLA is positively abutted against the shaft shoulder. This will ensure that rotor clearance on both its front and rear are maintained.

3. Using the rotor clamp with the rotor correctly positioned on the shaft and the TLA in place, a suitable screw is put through the centre hole in the clamp and tightened into the end of the shaft. This will hold the rotor in place and the TLA screws may now be tightened through the access slots in the clamp.
4. With the rotor clamp secured in place the TLA screws can be torqued up to the correct settings. To obtain best results it is recommended the screws are tightened in a diametrically opposed pattern, repeating until correctly set.

8.2 TLA Release Instructions

Loosen the socket head cap screw and remove the rotor cap ensuring that the two sealing O'rings are not lost. If the rotor cap does not release easily it can be removed by gently screwing a suitable screw into the thread in the centre hole of the rotor cap.

Loosen the TLA in several stages and in a diametrically opposite sequence. The loosened TLA can now be removed.

To extract the TLA from the rotor, only remove the two screws which are fitted with washers, carefully screw 8mm x 50mm bolts into the holes (these holes have only 3-5 threads) and pull out the TLA.

8.3 Rotor Retention: Torque Locking Assembly

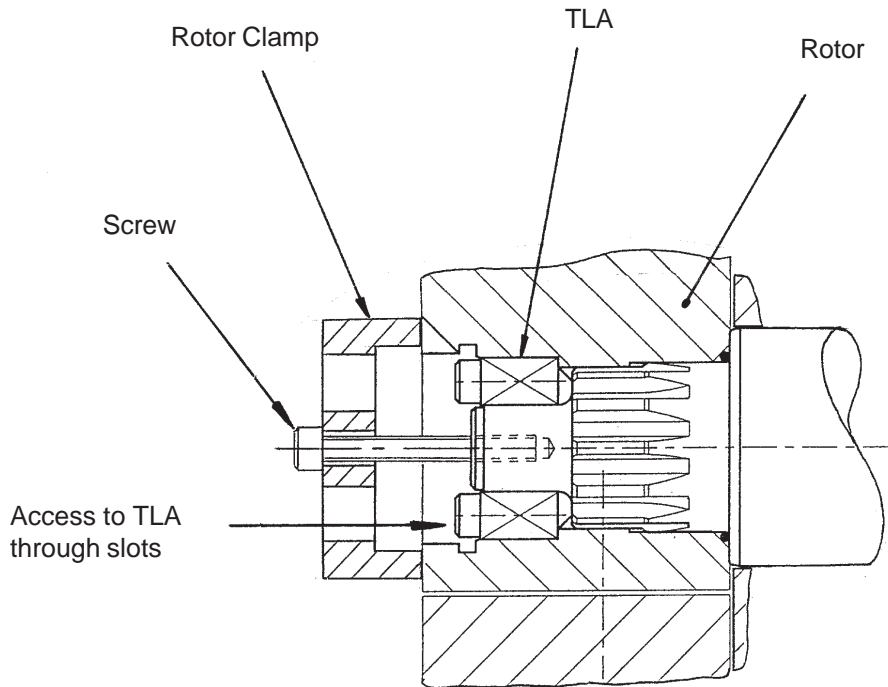

Torque Values for Rotor Torque Locking Assemblies

Pump	Torque Nm (lbft)	Key Size mm
D4	4.1 (3.0)	3
D5	8.5 (6.3)	4
D6	14.0 (10.3)	5

Operating Manual

9.0 General Maintenance

9.1 Before Dismantling the Pump

Before starting to dismantle the pump

Always:-



Purge -

the pump and system if any noxious products have been pumped.



Isolate -

pump/drive unit from all power and control supplies.

Close -

pipework valves to isolate the pump



Disconnect -

the pump from the drive unit.

**Read this section first before
continuing to dismantle the pump**

9.2 Removing the Rotors

1. Before starting to dismantle the pumphead isolate the driver/pump from all power and control supplies, purge the system if any noxious products have been pumped. Read the safety section carefully.
2. Ensure isolating valves to the pump are closed.
3. Carefully loosen the front cover retaining screws, there may still be residual pressure in the system.
4. Remove the front cover retaining screws and take off the cover. D5 and D6 pumps may have hinges fitted to the front covers. Having removed the front cover retaining screws the cover can be swung to one side.
5. Flush out the pumphead with a suitable cleaning agent before continuing.
6. Remove the rotor cap and torque locking assemblies.
7. Before removing the rotors their position should be noted such that they can be replaced easily. Mark the master rotor lobe, which centre line corresponds with the rotor spline teeth. See below.
8. Extract the rotors which should slide out from the splines. An internal groove is provided in the front of the rotor into which a suitable tool may be inserted to aid extraction. An illustration of a typical tool is shown below.

Typical rotor extraction tool

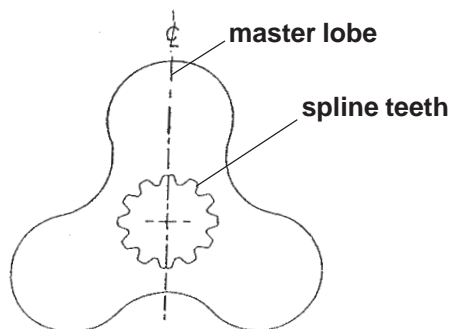
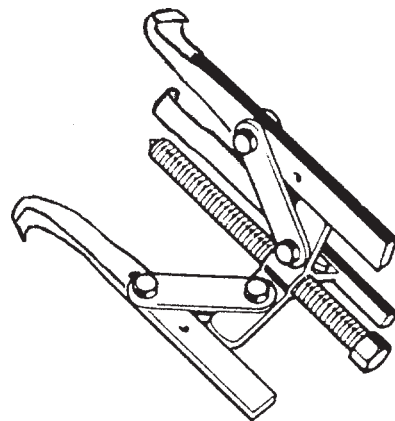

Operating Manual

9.3 Removing the Rotorcase

1. Before proceeding disconnect the suction and discharge piping.
2. Remove the rotors as described previously. On pumps D5 and D6 shut the hinged front cover (where fitted) and loosely fasten with front cover screws.
3. Loosen gland followers or when fitted with a flushed seal arrangement remove the housing retaining nuts and ease the housing away from the rotorcase.
4. Remove the rotorcase retaining nuts, and tap the rotorcase forwards with a soft mallet until it clears the locking dowels. If the pump is fitted with mechanical seals, care must be taken to support the rotorcase as it comes off the dowels otherwise the mechanical seals may be damaged.

5. Between the rotorcase and gearcase, preshaped plastic shims are used to adjust the rotor clearances. These must be replaced exactly as removed, otherwise excessive wear or damage may occur to the rotors and/or rotorcase.
6. Once the rotorcase is removed the seals/gland packing can be examined.

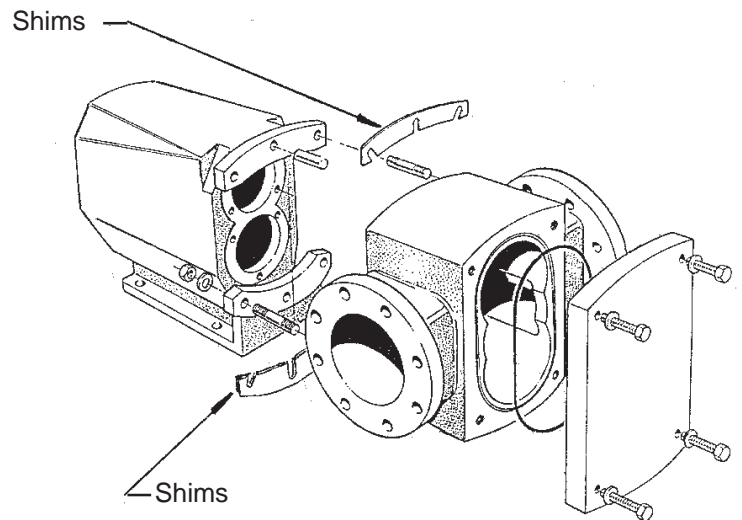

9.4 Replacing the Front Gearcase Seals

1. Follow the procedure for the removal of rotors and rotorcase.
2. Remove the product seal.
3. Three socket head screws retain the seal carrier, once removed the carrier can be extracted. As silicon sealant or a gasket is used to seal the faces the carrier may have to be eased off carefully with a lever.
4. Once the carriers are removed from the pump the seals can be pressed out and replacements pressed in using a suitable dolly.
5. Ensure the surface area which the seal will run on is free from scratches, if the surface is scratched clean up damaged area with a fine grade abrasive cloth. Ensure that all traces of abrasive material are cleaned away before refitting the new oil seals.
6. Before replacing the seal carriers, clean the old silicon sealant (if used) from the rear face of the carrier and from the front face of the gearcase. Coat the rear face of the carrier with new liquid gasket, slide into position and replace the three socket head screws. It must be noted that one of the three screws is longer, this should be inserted in the hole which aligns with the largest hole in the gearcase. Tighten the screws evenly to the recommended torque value.
7. Reassemble the seals and rotorcase, see the relevant sections for refitting procedure.

Note : It is advisable at this point to check for bearing end play, as this may be the cause of the seals leaking.

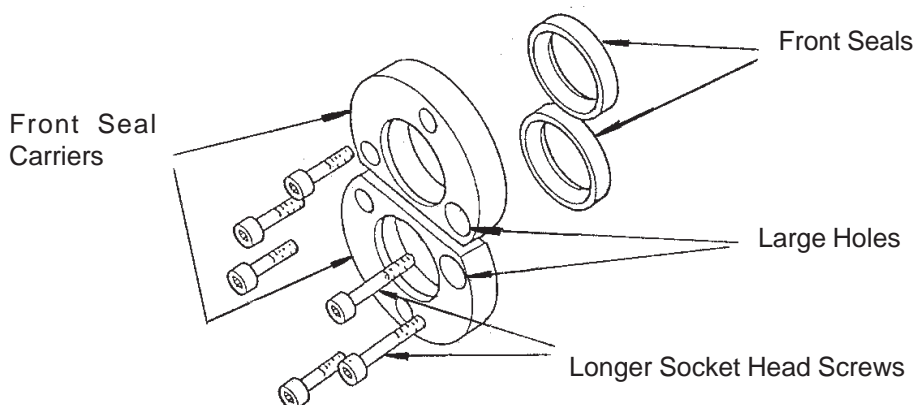

Operating Manual

9.5 Fitting and Shimming the Rotorcase

When fitting a rotorcase correct shimming is critical. Shims are fitted between the rotorcase and gearcase and are used to control the back clearances between the rotor and rotorcase. Plastic colour coded shims are used on all series D pumps. If the pump has previously been shimmed, the old shims may be reused provided they are replaced in their original positions. It is essential that equal shimming is used both top and bottom of the rotorcase to ensure that equal clearances are maintained across the rotor faces.

To reassemble the rotorcase the following step by step procedure should be used :-

- Check the seals are correctly fitted.
- If the rotorcase has previously been shimmed, replace the old shims in their original positions.
- Alternatively, if new shims are to be fitted the shimming process commences with 'too few' shims. Fit the rotorcase and torque up the gearcase nuts, fit the rotors and tighten to the recommended torque. With 'too few' shims fitted measure the back clearances (the clearance between the back of the rotors and rotorcase), and determine the additional shimming required to bring the clearance within tolerance.

Note : For the correct clearance dimensions please contact your supplier.

- Fit the additional shims, and recheck the clearances. If necessary repeat the above exercise until the clearances come within tolerance.

Care should be taken when sliding the rotorcase over the shafts so as not to damage the mechanical seals if fitted. When fitting the shims ensure that similar clearances are achieved both top and bottom of the rotorcase.

9.6 Front Cover Reversal

The front cover of all pumps in the series D range is of a flat and symmetrical design thus making it reversible. Therefore, when the inside face of the front cover becomes worn it may be reversed. In due course both sides will become worn and the cover will have to be replaced.

Isolate the driver/pump from all power and control supplies. If any noxious products have been pumped, the system should be purged.

Ensure isolating valves to the pump are closed. Loosen and remove the front cover retaining screws and remove the front cover.

In the case of D5 and D6 pumps loosen and remove the screws which hold the front cover to the hinge. Be sure to retain the washers fitted under the screw heads. Thoroughly clean the front cover. Inspect 'O' ring and replace if necessary.

Before replacing front cover simply reverse it such that the unworn side faces the pump. In the case of the D5 pumps ensure that the cover is orientated such that the hinge fixing holes line up with the hinge.

In the case of D5 and D6 pumps refit the hinge to the cover by refitting the hinge retaining screws, make sure that the washers are refitted under the screw heads. Ensure that the ends of the hinge retaining screws are flush with the inside of the front cover when fully tightened.

Fit front cover and tighten retaining screws to the recommended torque values.

9.7 Removal of Rear Gearcase Cover and Replacement of Seal

1. Isolate the motor, remove any coupling or Vee belt guards.
2. If the pump is direct coupled it will be necessary to disconnect the coupling and remove the pump from the baseplate before removing the gearcase cover.
3. If the pump is belt driven, release the tension on the belts and remove them, remove the pulley and drive key.
4. Drain the oil from the pump.
5. Remove the retaining screws and then remove the gearcase cover by sliding it along the drive shaft. As the cover is sealed to the gearcase with a liquid gasket it may require a sharp tap with a mallet and punch to break the joint.
6. With the cover removed, press out the oil seal from the cover and replace with a new seal.
7. Clean the faces of both the gearcase and the end cover, coat the faces with a suitable liquid gasket and refit the end cover. Replace the retaining screws then centralise the lipseal on the shaft before tightening to the recommended torque value.
8. Refill the pump with oil.

9.8 Refitting the Rotorcases

1. All rotors in the series D pump range have sealing 'O' rings as described previously. Check the condition of the 'O' rings and fit new rings if necessary.
2. Rotors are fully interchangeable. When refitting the rotors correct timing is achieved by replacing the rotors in exactly the same positions as when removed. If the gears have been removed or the

gearbox dismantled the pump will have to be retimed as described in the timing adjustment section.

To refit the rotors the recommended procedure is as follows :-

- rotate the drive shaft until the keyway's uppermost (not essential).
- find the master lobe of the rotor which centre line is the same as that of the spline teeth. See below.

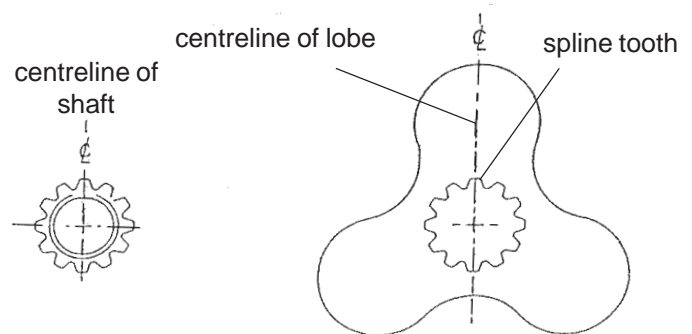

- line the master lobe up with the shaft spline and slide the rotor onto the shaft.
- find the master lobe of the remaining rotor as previously done.
- slide the rotor on so that both rotors are in the position shown below.

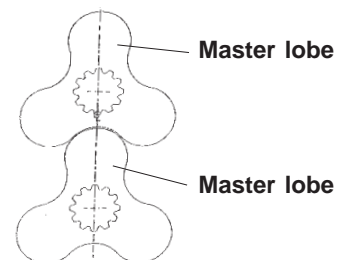

Correct timing has been achieved when the pump rotates freely without contact taking place between the rotors, this should always be checked prior to running the pump.

3. Replace the 'torque locking assemblies'. Refer to section 8.1 on page 23 for full details.
4. Before refitting the front cover examine the 'O'ring and replace it if damaged. Fit front cover and tighten the nuts up to the recommended torque values.

Operating Manual

9.9 Wearplates

Replacing Wearplates

All pumps in the series D range can be fitted with wearplates. When worn the wearplates can be replaced thus increasing the life of the pump.

Wearplates can be replaced without removing the rotorcase, but access to the wearplate retaining nuts may be increased if the rotorcase is removed.

Removing Old Wearplates

1. Remove the front cover and rotors as described. If considered necessary, remove rotorcase.
2. Loosen and remove the wear plate stud retaining nuts from the rear of the rotorcase.
3. Next the wearplates, with the studs still attached, may be removed from the front of the rotorcase where the wearplates will be seated.

1. Before fitting new wearplates thoroughly clean the inside of the rotorcase where the wearplates will be sealed. In addition wipe clean the rear face of the new wearplates.
2. The new wearplates will be supplied with the studs already attached.
3. Just prior to fitting the wearplates apply silicon sealant, or similar, to the wearplate studs.
4. Insert the new wearplates through the front of the rotorcase ensuring that the studs pass through the holes in the rear of the rotorcase.
5. Assemble nuts to the studs at the rear of the rotorcase and tighten to a torque of 8Nm (5.9 lbft).

Fitting New Wearplates

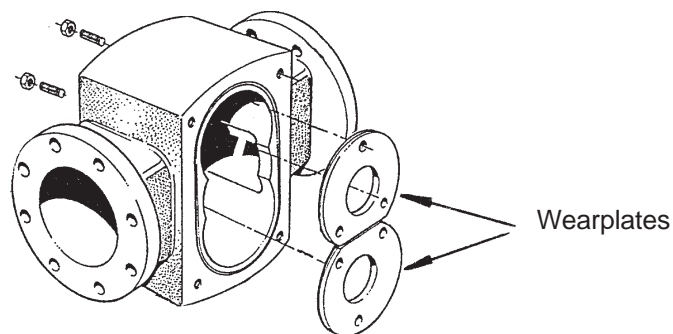

10.0 Gearbox Components

10.1 Timing Gears

Each pump is fitted with a pair of timing gears, which are located in the rear of the gearcase and ensure synchronisation of the rotors, such that under normal working conditions they will not contact one another.

The timing gears on pumps in the D range are retained using Torque Locking Assemblies (TLA) similar to those used to retain the rotors. The method of correctly tightening the TLA's is the same as for the rotors as previously described.

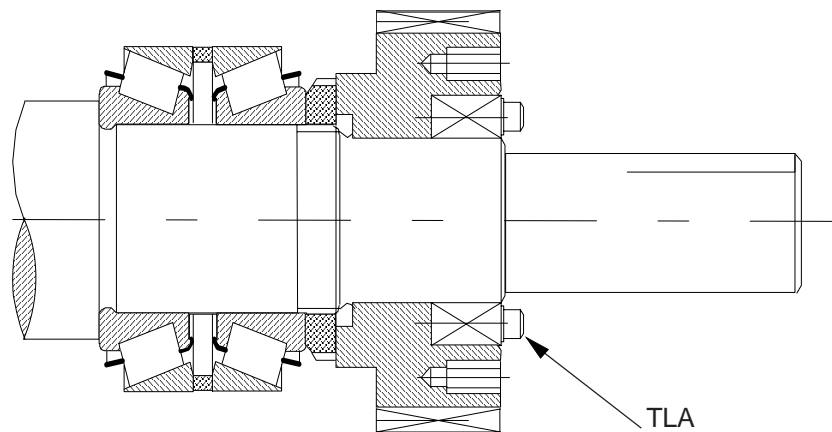

Timing Gears

Pump	Torque Nm (lb/ft)	Key Size mm
D4	14 (10)	5
D5	35 (26)	6
D6	35 (26)	6

Operating Manual

10.2 Timing Adjustment

The rotor timing (synchronisation) is set-up in the factory. If the rotors become unsynchronised, they may be retimed using the following procedure.

The cause of the fault should be established and eliminated before proceeding.

To adjust the timing of the rotors, first remove the gearcase end cover, once the cover is removed the timing gears will be exposed.

To retime the rotors, only one of the timing gear retainers need to be released sufficiently, to allow the rotors to be tapped into a position where they are synchronised. The rotors are correctly synchronised when the clearances at the measurement points are equal.

Diagram of Rotors Showing Timing

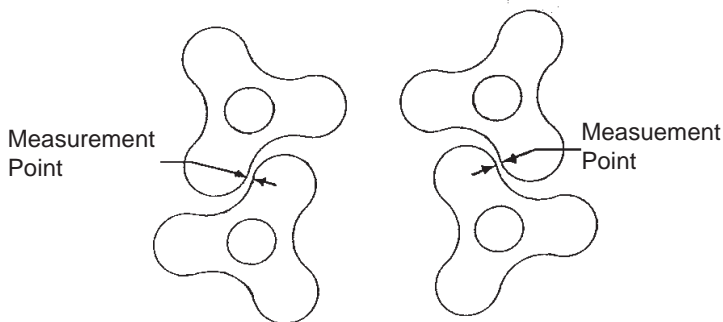

Use feeler gauges to measure the clearances at the positions illustrated, and adjust until equal, the pump is then correctly timed. Tighten the screws of the torque locking assembly to the correct values and replace the gearcase cover.

10.3 Timing Adjustment

Removing the timing gears is a reasonably simple operation though difficulty may be experienced in sliding the gears off the shaft. If this is the case an extractor tool may be required. For this purpose threaded holes are provided in the gears.

To remove the timing gears the following procedure is recommended.

1. Drain lubricant.
2. Remove rear gearcase cover.
3. Release torque locking assemblies. (refer to page 23 - 8.2)
4. An extractor tool may be required to pull the gear off. Because the gearcase has twin lubricated chambers lubricant may drain out when the top gear is removed.

10.4 Lip Seal - Removal & Refitting

The bearing lip seal fits behind the top shaft rear bearing housing. The lip seal runs on a boss at the back of the timing gears, and prevents the top chamber lubricant from draining into the bottom chamber. If the lip seal is to be reused care should be taken when extracting it not to damage the sealing edge, otherwise a new lip seal should be fitted. To refit a seal, it should be pressed evenly into the hole, and a flat plate or dolly used to drive it home.

10.5 Fitting the Timing Gears

1. Fit the rotors to the shafts to establish the timing.
2. Check that the bearing lip seal is fitted. Check that the boss on the back of the gear is smooth, and smear some lubricant onto it.
3. Slide on the gears. Where gears are marked as pairs they should be refitted with the timing marks aligned.
4. Fit the torque locking assemblies, and torque 'one' of them up. Adjust the timing, before tightening up of the last gear.

10.6 Shaft Removal

1. Remove rotorcase front cover, rotor and rotorcase.
2. Remove product seals.
3. Remove the gearcase rear cover, timing gears and drain lubricant.
4. Remove the gearcase front seal retainers and seals.
5. The shaft assemblies can now be removed through the front end of the gearbox, a soft faced mallet may be used to tap them out. The top chamber can now be completely drained. Ensure that the spacer located in the front bottom shaft bearing housing is retained for refitting.

10.7 Bearings - General

The series D range of pumps utilise taper roller bearings which are arranged in two sets of double bearings front and back, assembled with individual spacers. Refer to the exploded diagrams at the rear of the manual.

10.8 Bearings Removal

To remove the bearings, undo the notched bearing nut using a C- spanner, the bearing assembly can now be dismantled. The bearing cones are shrunk onto the shaft and will require pressing off.

10.9 Fitting Bearings to Shaft

1. Load shaft into vice in a vertical position and apply anti-seize compound to the bearing diameters.
2. Working first on the front set of bearings, use an induction heater or oil bath to heat the front bearing cone to 110°C. Pass the bearing over the rear bearing diameter and ensure a positive fit on the front bearing diameter against the shaft shoulder. The bearing taper should be towards the gear end of the shaft.

3. Locate outer shell of bearing onto the cone just fitted.
4. Locate bearing spacer onto shell just fitted.
5. Locate rear bearing shell, of front set of bearings, onto the spacer.
6. Heat rear bearing cone to 110°C and fit to bearing diameter. The taper should be towards the rotor end of the shaft.
7. Allow bearings to cool.
8. Locate shaft in vice in horizontal position.
9. Apply Permabond grade 145 sealant or equivalent to the shaft front lock nut thread and screw front lock nut onto the shaft. Whilst continuously rotating both bearings and spacer, torque up the bearing lock nut until the spacer cannot be moved radially (off the shaft centre line) by finger pressure alone, but can be moved with a light blow of a hammer.
10. Repeat the above procedure for the rear set of bearings, but in this case torque up the lock nut until the spacer can be just moved by finger pressure alone.

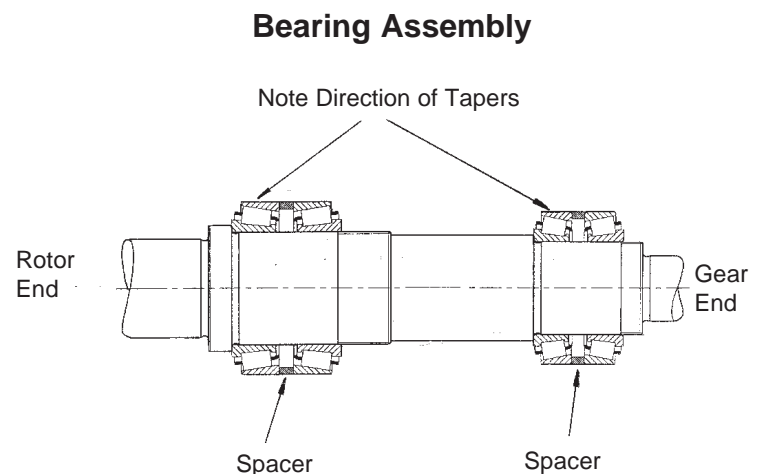

Operating Manual

10.10 Shaft Replacement

Gearboxes are assembled with the top shaft bearing located against a machined surface in the bearing housing, and the bottom shaft bearings butting against a spacer fitted into the front bearing housing. When a new gearbox is being built this spacer is initially oversized, such that the axial displacement in the rotor abutment shoulders can be measured and the appropriate spacer fitted, or the existing spacer ground to suit. When rebuilding a used gearbox the axial displacement should be checked, however, it will normally be within tolerance, 0.012mm.

Rotor Abutment Alignment

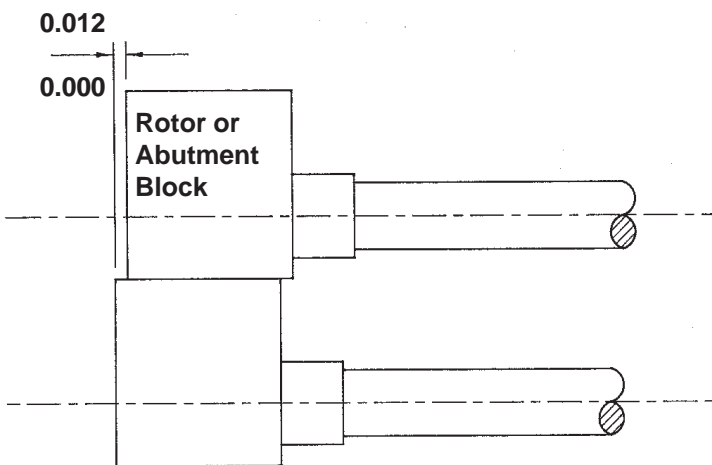

Note : The axial displacement can be in either direction as long as it is within tolerance.

1. Replace shaft abutment spacer into the front bottom bearing housing of the gearcase, between the front bearing and the housing.
2. Fit auxiliary shaft into gearcase.
3. Fit drive shaft into gearcase.
4. Fit seal retainers to the gearcase without silicon sealant at this stage, and torque the cap screws to their recommended value.
5. Fit rotors or shaft abutment blocks to the shafts and torque the rotor torque locking assemblies to the recommended value.
6. Using a depth micrometer measure from the front face of the bottom rotor to the front face of the top rotor, and record the axial displacement of the rotor abutment shoulders. When measuring off a pair of rotors it is important to compensate for any small differences there may be in the rotor lengths.
7. The axial displacement should be less than 0.012mm, if it is not the bottom shaft should be removed and the spacer ground or an appropriate spacer fitted to give a axial displacement of not greater than 0.012mm.
8. Once both shaft shoulders are within tolerance of each other, remove both seal retainers, fit the front oil seals, apply silicon sealant to the retainer face and torque up. Recheck to ensure alignment.
9. With the shafts installed the timing gears and front end of the pump can be refitted. The pump should now be timed, as previously described.

11.0 Product Seals Removal and Fitting

11.1 Single Mechanical Seal

Item	Description
1	Stationary Face 'O' Ring
2	Stationary Face
3	Rotary Face
4	Shaft 'O' Ring
5	Wave Spring
6	Drive Ring

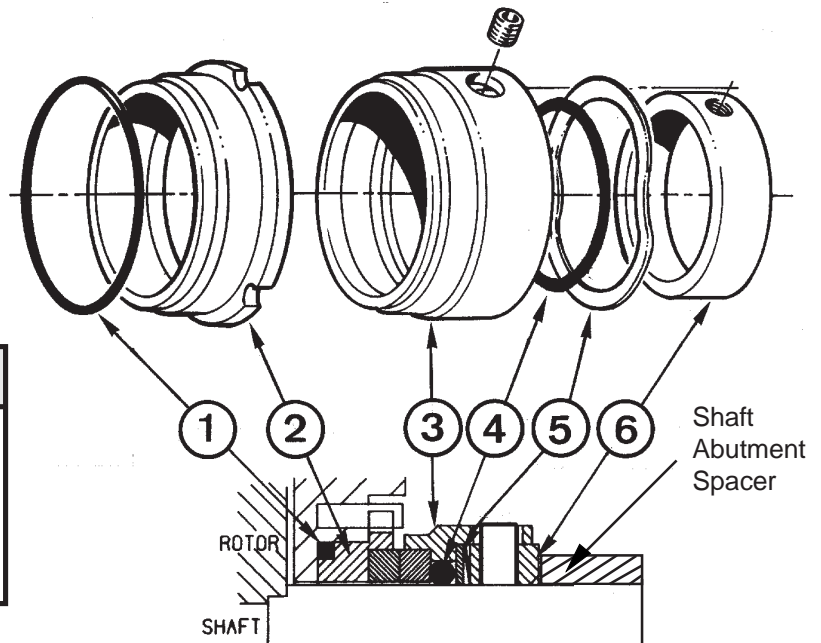

The seal comprises of a rotary face which is sealed to the shaft by an 'O' ring. A wave spring(s) provide a force to maintain face to face contact. Rotation is provided by socket set screws which are tightened onto the shaft. The stationary face is located in the rotorcase and is prevented from rotating by three pins.

**Seal faces are extremely brittle.
Take extreme care when handling.**

Removing the Single Mechanical Seal

1. To release the seal from the shaft loosen the socket set screws.
2. Remove the rotorcase with the stationary sealing face still within its bore, taking care not to chip the face.
3. Carefully remove the remaining part of the seal from the shaft.

Fitting the Single Mechanical Seal

1. Use a solvent to wipe the lapped surface of the seal faces until perfectly clean, being extremely careful not to scratch the faces.
2. Lightly lubricate the 'O' ring and shaft end with a silicon grease (food quality if necessary).
3. Firmly press the stationary face 'O' ring onto the stationary face edge and locate within the rotorcase bore over the roll pins.
4. Mark the shaft to indicate the seal setting length.
5. Push the 'O' ring within seal assembly face bore and gently slide the seal onto the shaft until it reaches the setting position.
6. Tighten the socket set screws.

Operating Manual

11.2 Single Flushed Mechanical Seal

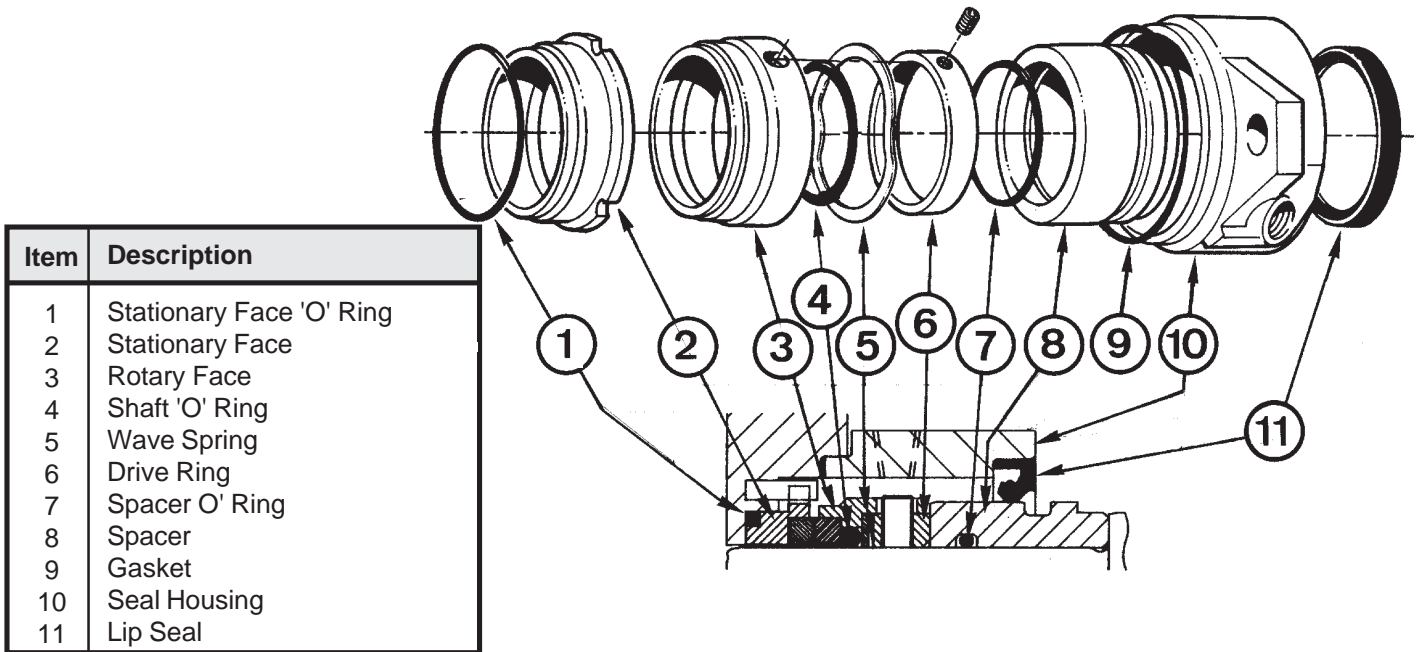

The seal comprises of a rotary face which is sealed to the shaft by an 'O' ring. A wave spring(s) provide a force to maintain face to face contact. Rotation is provided by socket set screws which are tightened onto the shaft. The stationary face is located in the rotorcase and is prevented from rotating by three pins. A seal housing with lip seal encloses the seal and runs on a shaft sleeve.

**Seal faces are brittle.
Take exteme care when handling.**

Removing the Single Flushed Mechanical Seal

1. To release the seal from the shaft loosen the socket set screws through the flushing connection.
2. Remove the seal housing retaining nuts and pull it away from the rotorcase.
3. Remove the rotorcase with the stationary sealing face still within its bore, taking care not to chip the face.
4. Carefully remove the remaining part of the seal from the shaft followed by the seal housing, lip seal and spacer.

Fitting the Single Flushed Mechanical Seal

1. Press the lip seal into the seal housing.
2. Lubricate spacer 'O' ring, fit into spacer and push onto the shaft.
3. Carefully guide the seal housing with lip seal over the spacer.
4. Use a solvent to wipe the lapped surface of the faces until perfectly clean, being extremely careful not to scratch the faces.
5. Lightly lubricate the 'O' ring and shaft end with a silicon grease (food quality if necessary).
6. Firmly press the stationary face 'O' ring onto the stationary face and locate them within the rotorcase bore over the roll pins.
7. Push 'O' ring within seal face bore and gently slide the seal onto the shaft until it reaches the spacer.
8. Tighten the socket set screws through the flushing holes.
9. The rotorcase can now be refitted whilst at the same time locating and tightening the seal housing nuts.

11.3 Double Mechanical Seal

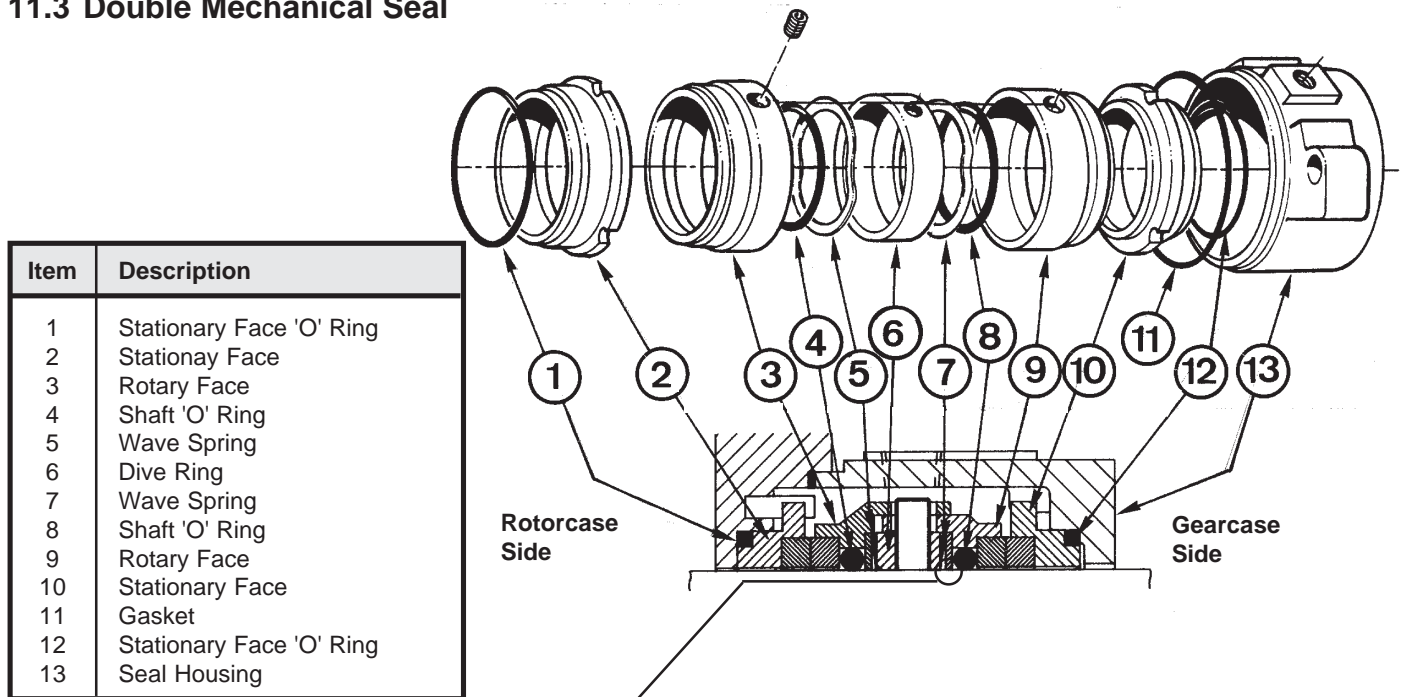

Note:- The drive ring chamfer must be on the gearcase side of the shaft.

The seal consists of two rotary faces which are sealed to the shaft by 'O' rings. Rotation is provided by socket set screws which tighten onto the shaft. The two stationary faces are located in the rotorcase and seal housing bores. Rotation is prevented by pins and cast lugs. Wave spring(s) provide a face to maintain face to face contact. As seal housing attached to the rotorcase encloses and sets the seal.

**Seal faces are brittle.
Take extreme care when handling.**

Fitting the Double Mechanical Seal

1. Use solvent to wipe the lapped surface of the seal faces **perfectly** clean, being extremely careful not to scratch the faces.
2. Lightly lubricate the 'O' rings and shaft end with silicon grease (food quality if necessary).
3. Firmly press on the 'O' rings to the stationary faces and locate them within the rotorcase bore and seal housing.
4. Locate 'O' rings into rotary faces.
5. Carefully fit the seal housing with stationary face onto the shaft.
6. Push the rotary assembly onto the shaft until it sets against the seal housing stationary face.
7. Fit new seal housing gasket.
8. Carefully fit the rotorcase and tighten the seal housing nuts.
9. Tighten each of the seal socket set screws through the seal housing flushing holes.

Removing the Double Mechanical Seal

1. Using the flushing holes loosen each of the socket set screws.
2. Remove the seal housing retaining nuts and pull back the seal housing away from the rotorcase.
3. Carefully remove the rotorcase with the stationary face still fitted.
4. Slide the rotary faces off the shaft followed by the seal housing with remaining stationary face.

Operating Manual

11.4 Packed Gland Arrangements

Packed Gland

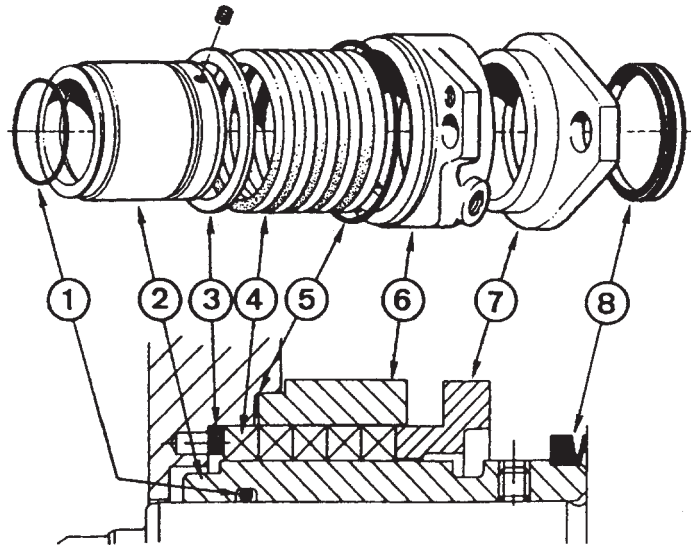

Item	Description	Item	Description
1	Shaft Sleeve O' Ring	5	Gasket
2	Shaft Sleeve	6	Gland Housing
3	Spacer	7	Gland Follower
4	Packing Rings	8	Ring Slinger

Drip leakage is essential to prevent overheating of the gland area which will cause seal failure.

The packing rings are located within the gland housing and are tightened onto the shaft sleeve by adjusting the gland follower. On flushed packed glands a lantern ring replaces the middle ring of packing. The shaft sleeve is retained to the shaft by three socket set screws and is sealed by an 'O' ring.

Removing the Packed Gland

1. Release and pull back the gland follower.
2. Remove the rotorcase with gland housing, packing and gland follower still assembled.
3. Loosen the shaft sleeve socket set screws and extract the sleeve from the shaft.
4. Inspect and replace the packing and shaft sleeve if necessary.

Fitting the Packed Gland

1. Lubricate the 'O' ring, locate in shaft sleeve and slide onto the shaft.
2. Tighten up the socket set screws, ensuring that the drilled dimples are aligned with the grub screws. Permabond A130 or equivalent should be used to secure grub screws in their positions.
3. Fit gland spacer, gasket and gland housing to the rotorcase.
4. Insert the packing rings and lantern ring (if flushed packed gland). Make sure they are in the correct order and positioned with the scarf joints 120° apart.
5. Loosely locate the gland follower and nuts.
6. Refit the rotorcase with packed assembly over the shaft sleeves.
7. Adjust the packed gland see next page.

11.5 Packed Gland Adjustment

Packed Gland with Flush

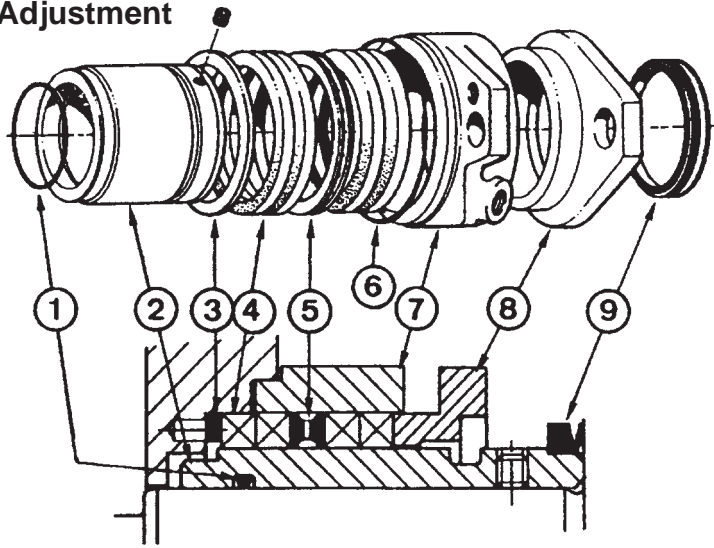

Item	Description	Item	Description
1	Shaft Sleeve 'O' Ring	6	Gasket
2	Shaft Sleeve	7	Gland Housing
3	Spacer	8	Gland Follower
4	Packing Rings	9	Ring Slinger
5	Lantern Ring		

Adjusting the Packed Gland

Drip leakage is essential to prevent overheating of the gland area which will cause seal failure.

Important :

Stop and remove gland guard for checking temperature of housing and observing leakage. **Always replace the guard before re-starting.**

1. Lightly tighten up the gland follower.
2. Flood the pumphead and determine if the gland leakage is acceptable. Tighten the gland follower nuts until an acceptable leakage is achieved.
3. Start the pump and allow to run for 10 minutes. If the gland becomes significantly hotter than other parts of the pump, the gland is too tight.

4. Stop the pump and allow it to cool then repeat the above until the gland temperature is stable and gland slightly weeping.
5. Run the pump at 10 minute intervals tightening the gland follower nuts by a $\frac{1}{6}$ of a turn until the leak is at an acceptable rate.

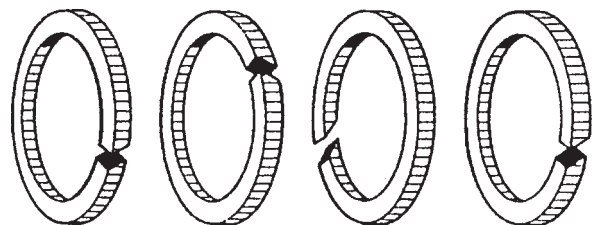

Operating Manual

11.6 Cartridge Mechanical Seal

The ACS type cartridge single mechanical seal is a bespoke seal for use mainly in arduous applications. The mechanical seal should not be disassembled without the use of special tools. The assembly is pre-loaded and incorrect disassembly may cause personal injury as well as invalidate any warranty.

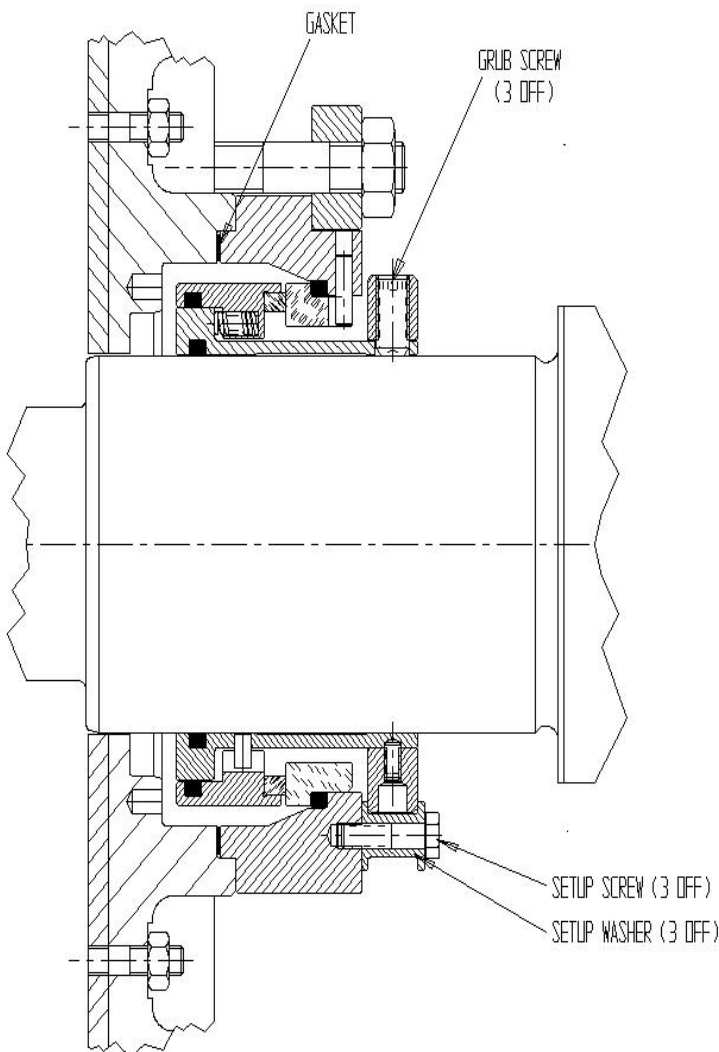

Note:

When seals are retro-fitted to replace AES units, the spacer must be removed so the ACS seal can be fitted direct to the pump casing.

Fitting Instructions:

1. Check the seal has the gasket fitted.
2. Slide seal onto shaft of pump as far back as it can go.
3. Repeat above for second shaft.
4. Assemble pump body to gearbox housing and tighten retaining bolts fully.
5. Slide one seal towards the pump body and ensure seal spigot enters seal area recess in pump body squarely.
6. Fit M10 nuts and spring washers to studs and tighten seal body to pump body.
7. Tighten seal to shaft by 3 x M8 (75mm unit) or M5 (45/55mm units) grub screws in drive collar (centralise sleeve to shaft by lightly tightening grub screws as first operation, then re-tighten to final torque of 15 Nm for M8 or 4.5 Nm for M5).
8. Undo setup screws and remove completely with setup washers (retain washers and screws for future maintenance use on pump).
9. Repeat steps 5 to 9 for second seal.

Seal Removal:

Removal of the seal assembly should be carried out in reverse order to fitting of the seal.

12.0 Faults, Causes and Remedies

No Discharge	Under Capacity	Irregular Discharge	Prime lost after starting	Pump stalls when starting	Pump overheats	Motor overheats	Excessive power absorbed	Noise & vibration	Pump element wear	Excessive gland seal wear	Product loss through gland	Seizure	CAUSES	REMEDIES
*													Increased direction of rotation.	Reverse motor.
*													Pump un-primed.	Expel gas from supply line and pumping chamber and introduce liquid.
*	*	*	*					*					Insufficient NPSH available.	Increase supply line diameter. Increase suction head. Simplify supply line configuration and reduce length. Reduce speed
*	*	*	*					*					Product vapourising in supply line.	Decrease product temperature - check effect of increased viscosity on available and permitted power inputs.
*	*	*	*					*					Air entering supply line.	Remake pipework joints. Adjust or repack gland.
*	*	*	*					*					Gas in supply line.	Expel gas from supply line and pumping chamber and introduce liquid.
*	*	*	*					*					Insufficient head above supply vessel outlet.	Raise product level. Lower outlet position. Increase submergence of supply line.
*	*	*	*					*					Foot valve strainer obstructed or blocked.	Service fittings.
*	*	*	*					*					Product viscosity above rated figure.	Decrease pump speed. Increase product temperature.
*	*	*	*					*					Product viscosity below rated figure.	Increase pump speed. Decrease product temperature.
*	*	*	*					*	*				Product temperature above rated figure.	Cool the product pumping chamber.
*	*	*	*					*	*				Product temperature below rated figure.	Heat the product pumping chamber. (Check with pump maker).
*	*	*	*					*	*				Unexpected solids in product.	Clean the system. Fit strainer to supply line.
*	*	*	*					*	*				Delivery pressure above rated figure.	Check for obstructions. Service system and revise to prevent problem recurring. Simplify delivery line.
*	*	*	*					*	*				Gland over-tightened.	Slacken and re-adjust gland.
*	*	*	*					*	*				Gland under-tightened.	Adjust gland. See not on packed glands under 'Installation and Maintenance' heading.
*	*	*	*					*	*				Gland flushing inadequate.	Check that fluid flows freely into gland. Increase flow rate.
*	*	*	*					*	*				Pump speed above rated figure.	Decrease pump speed.
*	*	*	*					*	*				Pump speed below rated figure.	Increase pump speed.
*	*	*	*					*	*				Rotorcase strained by pipework.	Check alignment of pipes. Fit flexible pipes or expansion fittings. Support pipework.
*	*	*	*					*	*				Belt drive slipping.	Re-tension to maker's recommendations.
*	*	*	*					*	*				Flexible coupling misaligned.	Check flange alignment and adjust mountings accordingly.
*	*	*	*					*	*				Insecure pump driver mountings.	Fit lock washers to slack fasteners and re-tighten.
*	*	*	*					*	*				Shaft bearing wear or failure.	Refer to pump maker for advice and replacement parts.
*	*	*	*					*	*				Worn un-synchronised timing gears.	Refer to pump maker for advice and replacement parts.
*	*	*	*					*	*				Gearcase oil quantity incorrect.	Refer to pump maker's instructions.
*	*	*	*					*	*				Metal to metal contact of pumping element.	Check rated and duty pressures. Refer to pump maker.
*	*	*	*					*	*				Worn pumping element.	Fit new components.

DIAGNOSIS WILL BE GREATLY ASSISTED BY TAKING ON-STREAM PRESSURE READINGS AT THE PUMPS INLET AND OUTLET PORTS

Operating Manual

13.0 Technical Data

13.1 Pump Information Chart

Pump Model	Displacement			Suction & Discharge Connections		Differential Pressure		Max Speed (Sludge)	Max Speed (Water)	Max Capacity (Water)	
	Litres/rev.	l gal/100 rev.	US gal/100 rev.	Connection Size international stds		bar	lbf/in	rev/min	rev/min	m³/h	l/sec
				mm	inches						
				mm	inches						
D4-0095	0.95	20.9	25.0	75	3	5.0	72	350	500	28.5	7.9
D4-0140	1.40	30.8	36.8	100	4	5.0	72	350	500	42.0	11.6
D5-0200	2.00	44.0	52.6	100	4	5.0	72	350	500	60.0	16.6
D5-0290	2.90	63.8	76.3	100 150 optional	4 6 optional	5.0	72	350	500	87.0	24.1
D6-0420	4.20	92.4	110.5	150	6	5.0	72	350	500	126.0	35.0
D6-0600	6.00	132.0	157.8	150	6	5.0	72	350	500	180.0	50.0

13.2 Seal Specification Chart

Pump Model	Mech Seal	Packed Glands					
		Standard			USA		
	Seal Size	Gland Packing Section (Square) mm	Number of Rings per Seal		Gland Packing Section (Square) mm	Number of Rings per Seal	
			Without Flush	With Flush		Without Flush	With Flush
D4	45	8	4	3	6.5	5	3
	45	8	4	3	6.5	5	3
D5	55	8	4	3	6.5	5	3
	55	8	4	3	6.5	5	3
D6	75	8	5	4	8	5	3
	75	8	5	4	8	5	3

13.3 Torque Specification Chart

Pump Model	Front Cover Screws		Rotor TLAs				Gearcase Nuts			Timing Gears TLAs		
	Torque		Spanner Size	Torque		Key Size	Torque		Spanner Size	Torque		Key Size
	Nm	lbft	mm	Nm	lbft	mm	Nm	lbft	mm	Nm	lbft	mm
D4	39	29	17	4.1	3	3	64	47	19	14	10	5
D5	39	29	17	8.5	6.3	4	64	47	19	35	26	6
D6	64	47	17	14	10.3	5	175	129	24	35	26	6

Front Seal Carriers and Rear Covers

Torque 25 Nm (19 lbft) - Key Size 6mm

Wearplates

Torque 8 Nm (5.9 lbft) - Spanner Size 10mm

Shaft Sleeve Retaining Screws

D4 Torque 4 Nm (2.9 lbft) - Key Size 3mm

D5 & D6 Torque 14 Nm (10.3 lbft) - Key Size 4mm

Operating Manual

14.0 Exploded Pump Drawing and Parts List

14.1 Priming Adaptor Ports

D4-0140 Priming Adaptor Option	
Item No	Description
61	Priming Adaptor
62	Gasket
63	Bolt
64	Washer
65	Nut
66	Blanking Plug

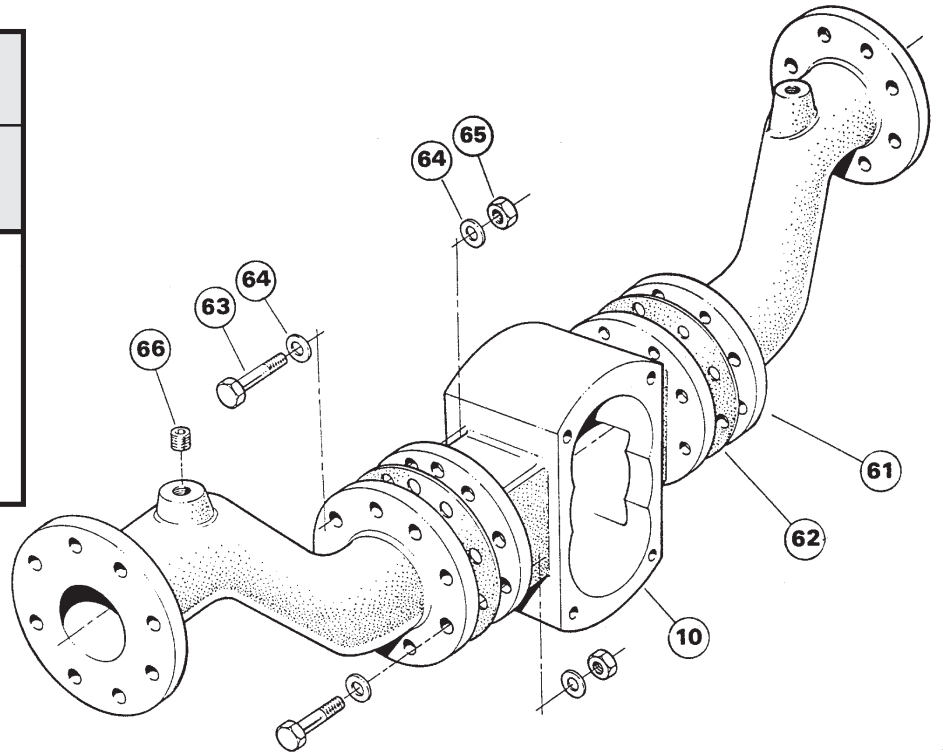

D4-0095 Priming Adaptor Option	
Item No	Description
71	Priming Adaptor
72	Gasket
73	Bolt
74	Washer
75	Nut
76	Rotorcase - Rectangular Ports

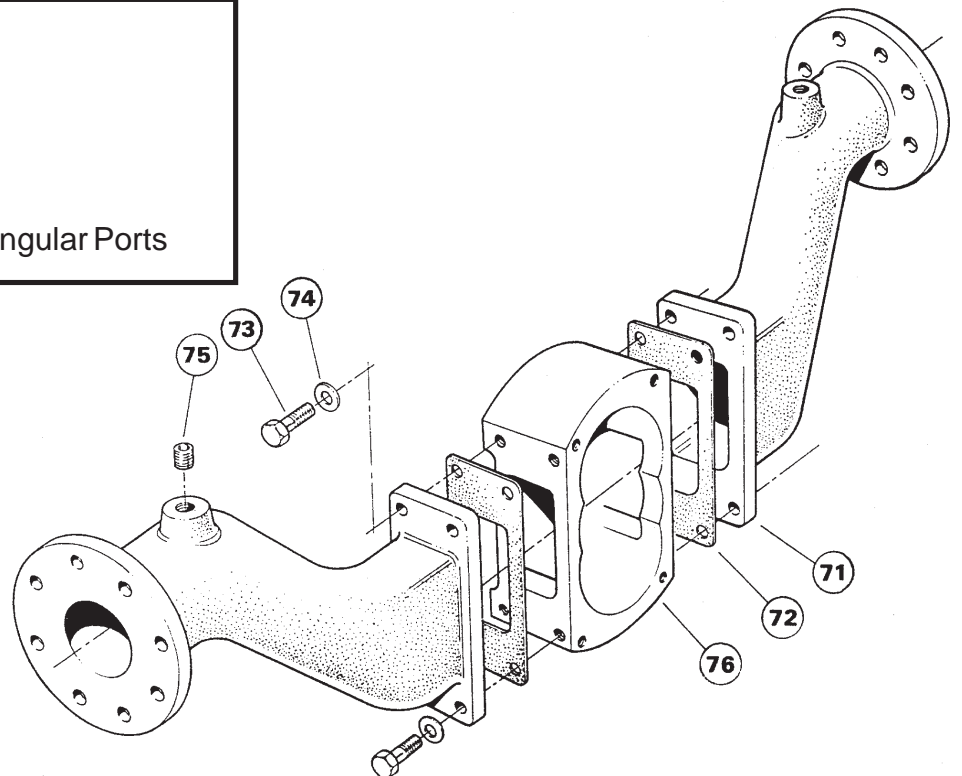

Exploded Pump Drawing and Parts List

14.2 D4

Item	Description	Item	Description
1	Gearcase	46	Plug
2	Dowel	47	Sight Level
3	Stud, Gearcase	48	Gasket
4	Nut, Gearcase Stud	49	Filler Plug, Oil
5	Washer, Gearcase Stud	50	Gasket
6	Cover, Gearcase		
7	Screw, Rear Cover		
8	Lip Seal (Drive End)		
9	Shim		
10	Rotorcase		
11	Wearplate		
12	Stud, Wearplate		
13	Nut, Wearplate		
14	'O' Ring, Front Cover		
15	Cover, Rotorcase		
16	Hex Head Screws, Front Cover		
17	Washer, Front Cover		
22	Screws, Front Seal Carrier, Short		
23	Screws, Front Seal Carrier, Long		
24	Lip Seals, Gland End		
25	Rotors		
26	'O' Ring, Rotor Sealing Shaft End		
27	Torque Locking Assembly		
28	Rotor Cap		
29	'O' Ring, Rotor Cap, Small		
30	'O' Ring, Rotor Cap, Large		
31	Screw and Washer, Rotor Cap		
32	Key		
33	Shaft, Drive		
34	Shaft, Auxiliary		
35	Bearing/s, Front		
36	Spacer, Bearing		
37	Spacer, Rotor Alignment		
38	Nut, Bearing		
39	Bearing/s, Rear		
40	Spacer, Bearing		
41	Nut, Bearing		
42	Lip Seal, (Bearing)		
43	Gear		
44	Torque Locking Assembly		
45	Plug		

Operating Manual

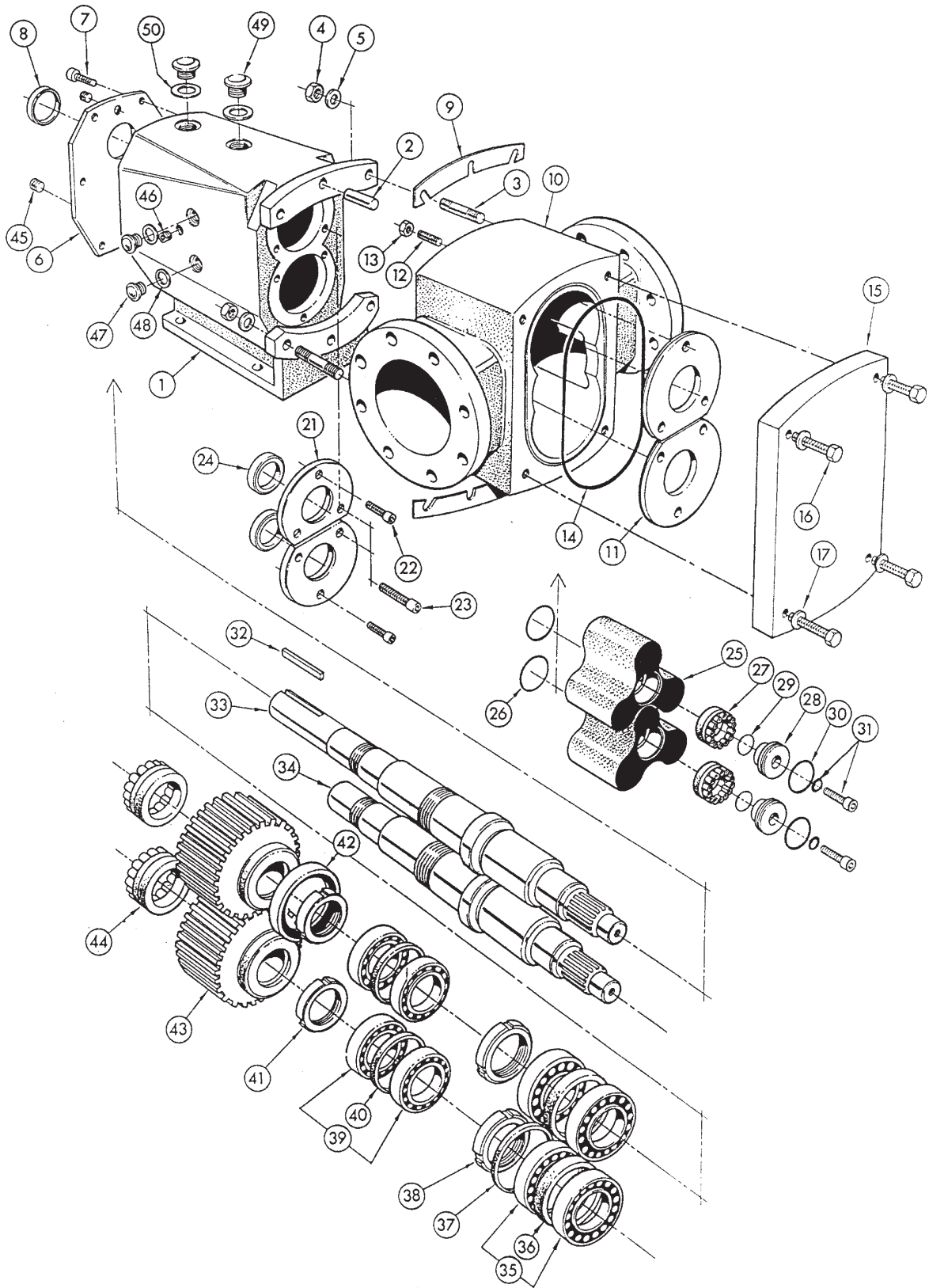

Exploded Pump Drawing and Parts List

14.3 D5

Item	Description	Item	Description
1	Gearcase	46	Plug
2	Dowel	47	Sight Level
3	Stud, Gearcase	48	Gasket
4	Nut, Gearcase Stud	49	Filler Plug, Oil
5	Washer, Gearcase Stud	50	Gasket
6	Cover, Gearcase		
7	Screw, Rear Cover		
8	Lip Seal (Drive End)		
9	Shim		
10	Rotorcase		
11	Wearplate		
12	Stud, Wearplate		
13	Nut, Wearplate		
14	'O' Ring, Front Cover		
15	Cover, Rotorcase		
16	Hex Head Screws, Front Cover		
17	Washer, Front Cover		
22	Screws, Front Seal Carrier, Short		
23	Screws, Front Seal Carrier, Long		
24	Lip Seals, Gland End		
25	Rotors		
26	'O' Ring, Rotor Sealing Shaft End		
27	Torque Locking Assembly		
28	Rotor Cap		
29	'O' Ring, Rotor Cap, Small		
30	'O' Ring, Rotor Cap, Large		
31	Screw and Washer, Rotor Cap		
32	Key		
33	Shaft, Drive		
34	Shaft, Auxiliary		
35	Bearing/s, Front		
36	Spacer, Bearing		
37	Spacer, Rotor Alignment		
38	Nut, Bearing		
39	Bearing/s, Rear		
40	Spacer, Bearing		
41	Nut, Bearing		
42	Lip Seal, (Bearing)		
43	Gear		
44	Torque Locking Assembly		
45	Plug		

Operating Manual

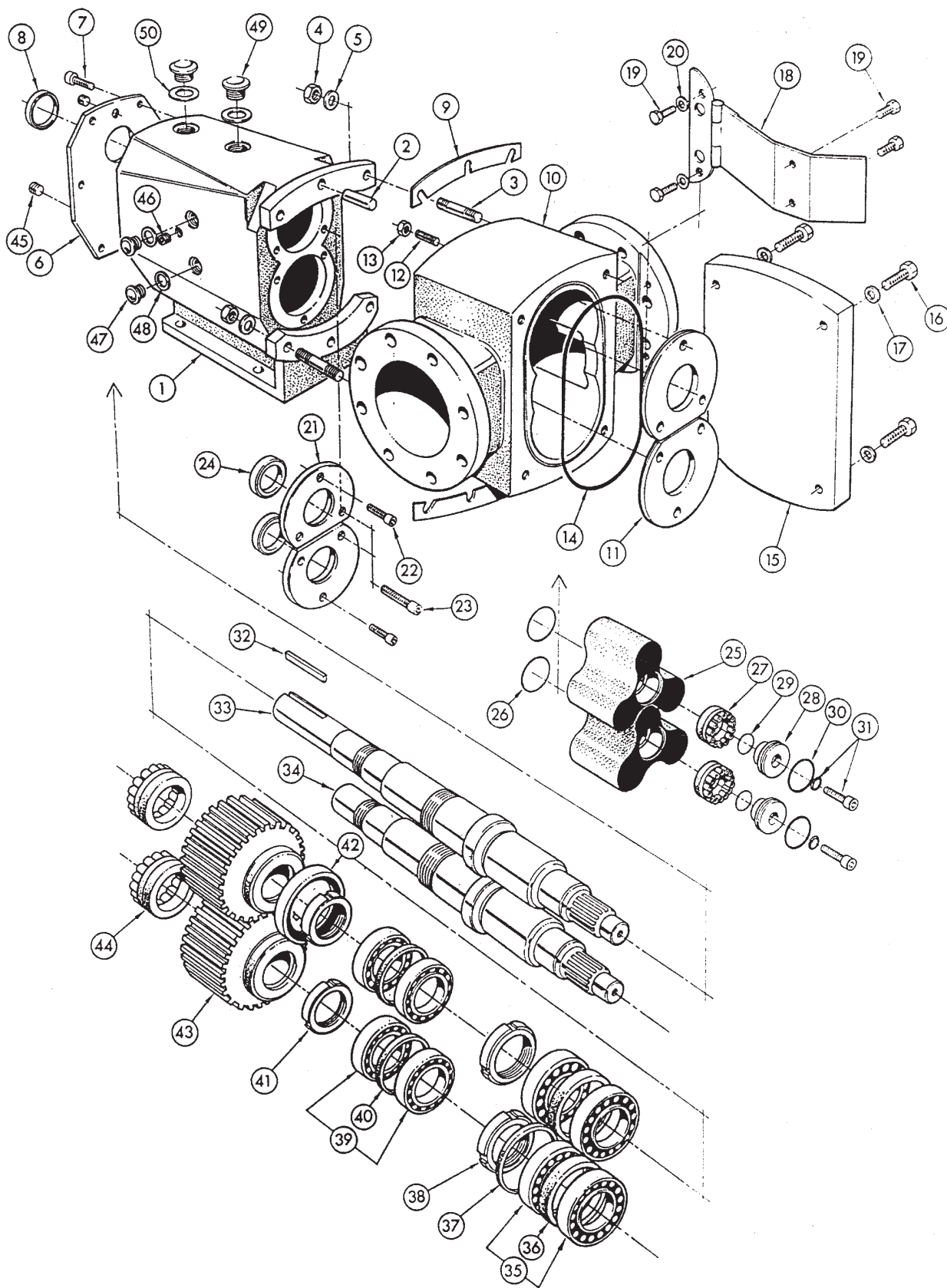

Exploded Pump Drawing and Parts List

14.4 D6

Item	Description	Item	Description
1	Gearcase	46	Plug
2	Dowel	47	Sight Level
3	Stud, Gearcase	48	Gasket
4	Nut, Gearcase Stud	49	Filler Plug, Oil
5	Washer, Gearcase Stud	50	Gasket
6	Cover, Gearcase		
7	Screw, Rear Cover		
8	Lip Seal (Drive End)		
9	Shim		
10	Rotorcase		
11	Wearplate		
12	Stud, Wearplate		
13	Nut, Wearplate		
14	'O' Ring, Front Cover		
15	Cover, Rotorcase		
16	Hex Head Screws, Front Cover		
17	Washer, Front Cover		
22	Screws, Front Seal Carrier, Short		
23	Screws, Front Seal Carrier, Long		
24	Lip Seals, Gland End		
25	Rotors		
26	'O' Ring, Rotor Sealing Shaft End		
27	Torque Locking Assembly		
28	Rotor Cap		
29	'O' Ring, Rotor Cap, Small		
30	'O' Ring, Rotor Cap, Large		
31	Screw and Washer, Rotor Cap		
32	Key		
33	Shaft, Drive		
34	Shaft, Auxiliary		
35	Bearing/s, Front		
36	Spacer, Bearing		
37	Spacer, Rotor Alignment		
38	Nut, Bearing		
39	Bearing/s, Rear		
40	Spacer, Bearing		
41	Nut, Bearing		
42	Lip Seal, (Bearing)		
43	Gear		
44	Torque Locking Assembly		
45	Plug		

Operating Manual

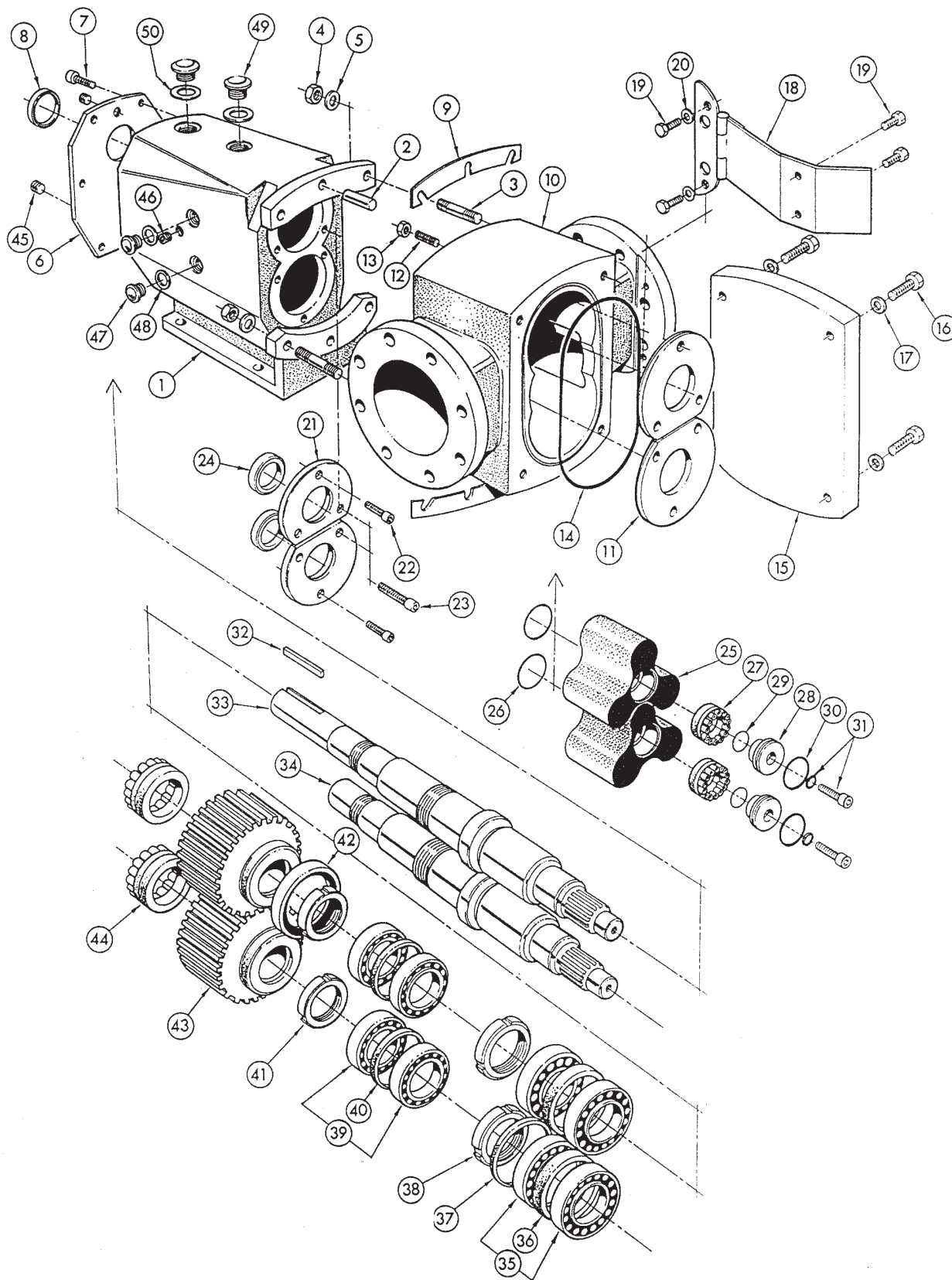

Alfa Laval Ltd
SSP Pumps
Birch Road, Eastbourne
East Sussex BN23 6PQ, England
Tel: +44 (0) 1323 414600
Fax: +44 (0) 1323 412515
www.ssppumps.com

The information contained herein is
correct at the time of issue but may be
subject to change without prior notice