

Poly-Sight Polysulfone Sight Glass



No Glass!



Matrix Process Solutions

ABN 28 097 144 897

ACN 097 144 897

VICTORIA:

Unit 1/25 Kilpa Rd,

Moorabbin 3189

Ph: (03) 9553 0928

Fax: (03) 9553 0987

SOUTH AUSTRALIA:

Unit 8/36 Birralee Rd,

Regency Park 5010

Ph: (08) 8244 1322

Fax: (08) 8244 1722

QUEENSLAND:

Unit 7/33 Meakin Rd,

Meadowbrook 4131

Ph: (07) 3200 3433

Fax: (07) 3200 2477

APPLICATION:

Inline sight glass designed for providing visual identification of product flow.
Polysulfone Lens material. (NO GLASS)

It can be effectively sanitized with standard CIP techniques and cleaning agents, remaining tough and durable in water, steam and chemically harsh environments.

High-performance thermoplastic resin is noted for its ability to resist deformation under load in a broad range of temperature and environmental conditions.

STANDARD DESIGN:

- Tri-Clamp connections
- Polysulfone Lens
- 10 Bar pressure rating
- 130 Deg C Max Internal Temperature. (Ambient external)
- EPDM Elastomers standard.
- 304 s/s or 316 s/s
- FDA, USDA and 3-A Dairy compliant
- Predrilled for quick and easy installation
- Indoor use only. Not suitable for high UV levels. (Outdoors)
 - Optional UV resistant guard available on request.

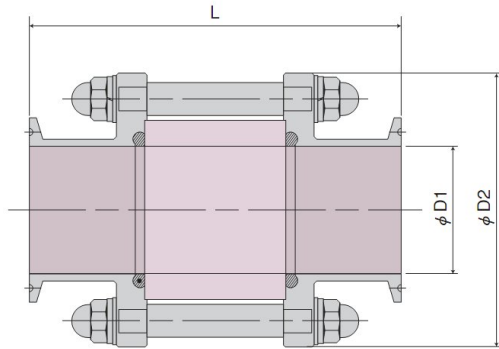

Part #		Size	Dimensions		
304s/s	316L s/s		D1	D2	L
			mm	mm	mm
025PS4	PSK0256	25	23	74	135
040PS4	PSK0406	38	35.7	88	135
050PS4	PSK0506	51	47.8	99	135
065PS4	PSK0656	63	59.5	114	160
080PS4	PSK0806	76	72.3	127	160
100PS4	PSK1006	101	97.6	155	160

