



Flow Transmitter

PD 340

Installation Guide

GB

© Copyright 2004 by **PROCES-DATA A/S**. All rights reserved.

PROCES-DATA A/S reserves the right to make any changes without prior notice.

P-NET®, **Soft-Wiring®** and **Process-Pascal®** are registered trademarks.

Contents

1	Installation of Transmitter	4
1.1	Choosing the best place for the PD 340 in the pipework	4
1.2	Power Supply	4
1.3	Connecting a PD 210 Display unit	5
1.4	Fitting the PD 210 into a control panel	5
1.5	Connecting a Pt-100 temperature sensor	6
1.6	Connecting to the P-NET	6
1.6.1	Electrical specification for P-NET	6
1.7	Connecting to PD 4000/340 Flowmeter-Display	6
2	Operating the PD 340 Flow Transmitter	7
2.1	Using Output 1	7
2.2	Using Output 2	7
2.3	Using Output 3	7
2.4	Using Input 1	8
2.5	Using the PD 340 in Test mode	8
2.5.1	Running Test mode from a PD 210	8
2.5.2	Running Test mode from a PD 4000/340	8
3	Service and specifications	9
3.1	Programming the PD 340	9
3.2	Program Enable switch	9
3.3	Dimensions and capacities	9

1 Installation of Transmitter

1.1 Choosing the best place for the PD 340 in the pipework

The Flow Transmitter should be installed within the pipework in such a way that the metering head is always filled with liquid. The PD 340 could interpret an empty pipe as if some liquid is flowing. If heavy vibrations occur in the pipework e.g. caused by resonance from pumps, or a pulsating pressure in connection with perhaps a homogenizer or a positive displacement pump, some vibration damping will be required, or the transmitter must be mounted somewhere else having less pressure variation. If the liquid contains air, an air eliminator should be mounted upstream of the Flow Transmitter.

The Flow Transmitter can be mounted horizontally as well as vertically. No air must be trapped in the metering head. An arrow on the metering head indicates the positive flow direction.

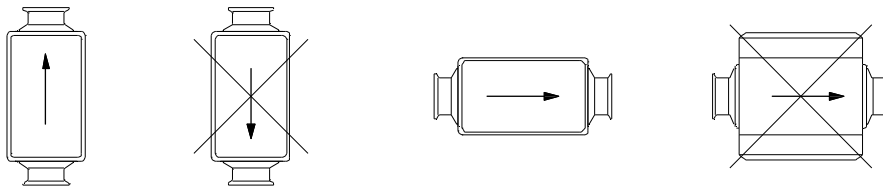

Vertical mounting

Horizontal mounting (seen from one side)

550 626 01

To create the best conditions for precise metering, a straight pipe run of at least three times the pipework diameter should be mounted upstream and downstream of the Flow Transmitter.

1.2 Power Supply

The figure below shows the terminal board with all the electrical connections for the Flow Transmitter.

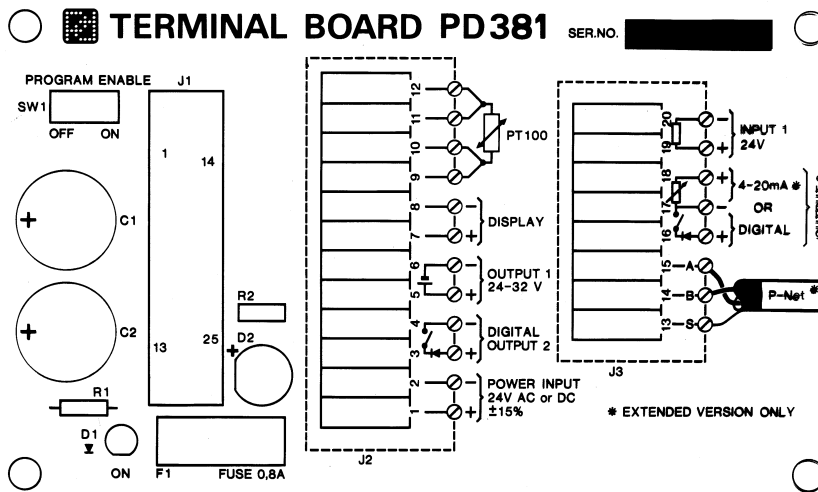

550 291 02

The Flow Transmitter requires 24 V DC or 24 V AC.

If the conductivity of the liquid is below 5 $\mu\text{S}/\text{cm}$, it may still be possible to measure the flow. To try this, the Flow Transmitter should be connected to a separate DC power supply and the -24 V DC terminal connected to the pipework. This will increase the sensitivity and flow measurement may be possible in spite of the low conductivity.

The Flow Transmitter should always be powered. This will prevent condensation in the electronics.

Power supply AC (50/60 Hz) or DC:	nom.	24.0 V
	min.	20.0 V
	max.	28.0 V
Fuse (time lag):		0.8 A
Power consumption:	max.	6.0 W

1.3 Connecting a PD 210 Display unit

Connect the two terminals on the back of the PD 210 Display unit, one marked "-", directly to the Flow Transmitter with a two-wire cable being up to 100 m long. The cable should be connected in the terminal box at terminal 7 (plus) and 8 (minus).

Using a shielded cable will improve the electrical noise immunity - especially when using a long cable. The shield must be connected to terminal 8 in the terminal box but should not be connected to the PD 210 Display unit.

1.4 Fitting the PD 210 into a control panel

The PD 210 is intended for panel mounting.

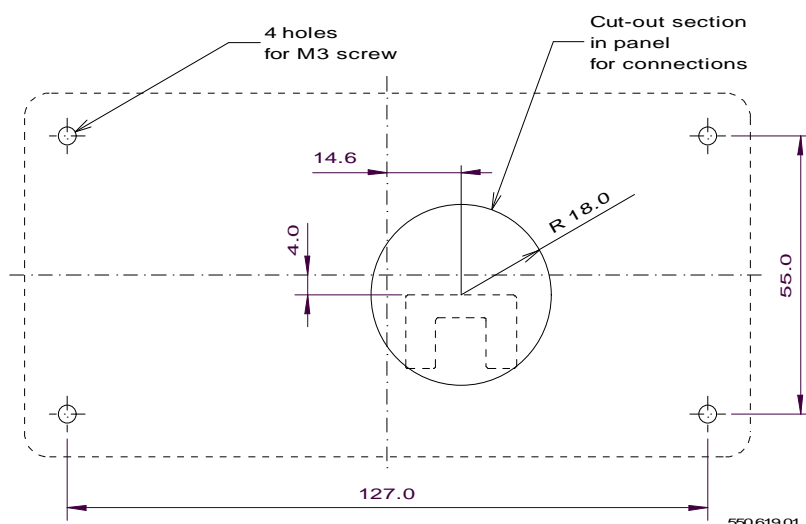

Note: Please observe that the M3 mounting screw holes are only 4 mm deep. Don't force the screws further down. This may damage the Display unit.

1.5 Connecting a Pt-100 temperature sensor

In the terminal box there are four terminals intended for connection of a standard Pt-100 temperature sensor. The temperature sensor must be connected with a 4-wire cable all the way from the sensor to the terminal box.

Note: When not using a temperature sensor, the terminals 9-10-11-12 must be short-circuited to avoid errors in the flow measurement.

1.6 Connecting to the P-NET

To connect to the P-NET, the PD 340 must be in extended version. To determine if the PD 340 is an extended version, unscrew the electronic module and check if the PC board inside has a label, which reads "Extended Version".

The PD 340 is connected to P-NET by means of three terminals in the terminal box marked S (13), B (14) and A (15).

Connecting several PD 340s together is performed by connecting A to A, B to B and S to S. The S terminal must not be connected to ground. If the total length of the cable is more than 100 m, the bus cable is required to be connected from field device to field device, to form a physical ring.

1.6.1 Electrical specification for P-NET

Bus structure: A physical ring without termination.

Medium: Shielded twisted pair cable with minimum 0.22 mm^2 area conductors and characteristic impedance of 100 - 200 ohm. For example TWINAX IBM part No. 7362211 with 105 +/- 5 ohms, 51 pF/m.

Bus length: Max. 1200 m (EIA RS 485).

1.7 Connecting to PD 4000/340 Flowmeter-Display

The connections are made between terminals 13, 14 and 15 in the terminal box and terminal 1, 2 and 3 on the back of the PD 4000/340. (See "Connecting to the P-NET").

2 Operating the PD 340 Flow Transmitter

The Flow Transmitter has three outputs and one input. The functions are briefly described below. For a more detailed description, please see the PD 340 manual 502010.

2.1 Using Output 1

Output 1 on the terminal board is a voltage supply, which can be used to supply an external counter circuit, relays or current devices (4-20 mA). The voltage at the output will vary, typically between 20 and 40 V DC depending on the supply voltage for the PD 340.

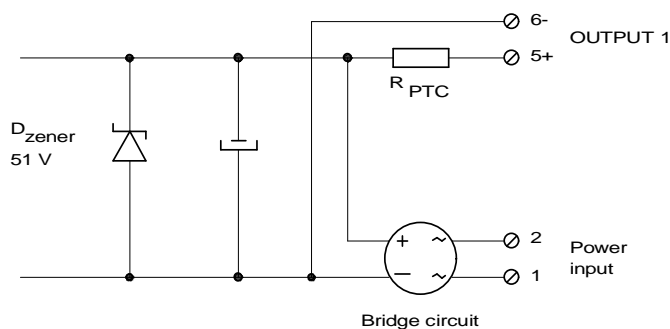

550 620 01

2.2 Using Output 2

The pulse signal from Output 2 has a pulse width of 40 ms. The frequency is variable from 0 to 10 Hz.

Connecting an electro-mechanical counter to Output 2:

Counter specification

Supply voltage:		20-40	VDC
Power consumption:	max.	2.5	W
Counting frequency:	min.	10	Hz
ON-time:	typ.	40	ms
OFF-time:	min.	60	ms

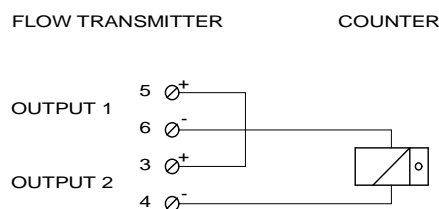

550 621 01

2.3 Using Output 3

Flow Transmitters in the standard version will generate pulses on Output 3 with a 50 - 50 % duty cycle and a frequency continuously variable from 0 to 1000 Hz. The output requires a voltage supply (Output 1 may be used).

Flow Transmitters in the extended version will generate either pulses on Output 3 with a 50 - 50 % duty cycle and a frequency continuously variable from 0 to 1000 Hz or a 4 - 20 mA current signal on Output 3. The output requires a voltage supply (Output 1 may be used).

2.4 Using Input 1

The input signal is galvanically isolated. To activate the input, a voltage of at least 18 V must be applied across the terminals 19 (+) and 20 (-). This voltage may be supplied either from the internal voltage supply or from an external power supply.

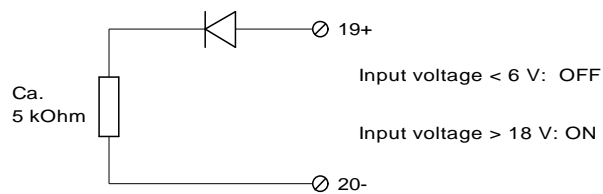

550 622 01

2.5 Using the PD 340 in Test mode

During installation and service, Test mode may be used to simulate flow in the pipe system. All output signals - pulses as well as the current signal - will act as if the liquid flow was present. This way, all internal functions, external signals and cable connections may be checked. In Test mode, you may key in the desired simulated flow in the flow register by pressing <FLOW>. Then key in the desired flow and press < = >. (Same procedure on PD 210 and PD 4000/340).

2.5.1 Running Test mode from a PD 210

To set the PD 340 in Test mode, first see "Program Enable switch". Then read out register E7 by pressing <E> followed by <7> on the PD 210. The display will now show "7" followed by a blank and six digits. Memorize the six digits. Key them in again but changing the fifth digit to "8". The Flow Transmitter is now in Test mode. To revert back to normal mode later, just key in the memorised six digits again into register E7.

2.5.2 Running Test mode from a PD 4000/340

To set the PD 340 (meter A) in Test mode first see "Program Enable switch". Then press <METER A>, <SETUP>, tick [MANUAL], press < = >, tick [CONFIG], press < = >, tick [FLOW], press < = >, tick [MODE], press < = >. Scroll with arrow buttons until the display reads "Test Mode" and press < = >. Finally press <METER A>. The display will now show "TEST MODE" on the bottom line.

3 Service and specifications

3.1 Programming the PD 340

For full details on programming the PD 340 please refer to the Flow Transmitter manual 502010.

3.2 Program Enable switch

The program enable switch SW1, located in the upper left corner of the terminal board, must be in position ON to enable configuration and calibration of the PD 340. After configuration and calibration the switch must be set in the OFF position.

3.3 Dimensions and capacities

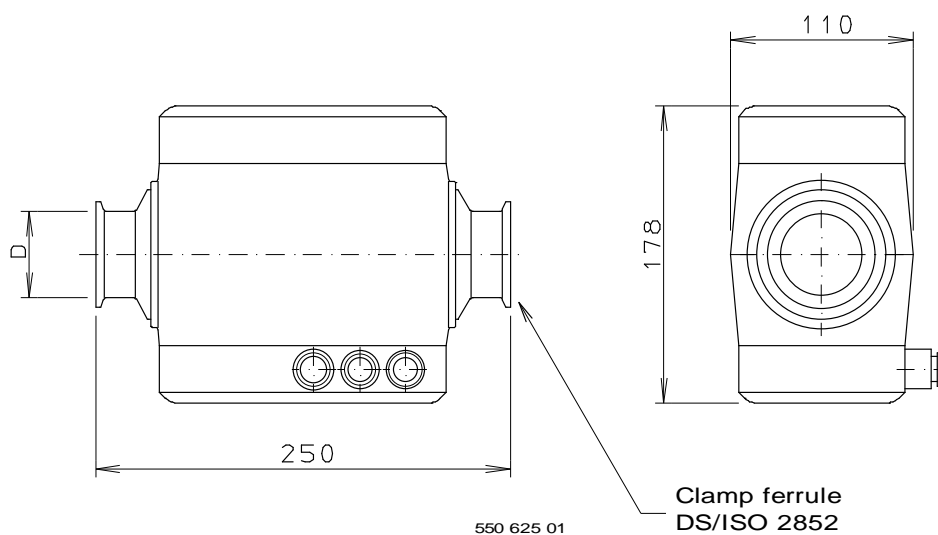

Meter size	Nom. size D in mm	Capacity m ³ /hour	Weight in kg
C 25	25.0	8	5
C 38	38.0	20	5
C 51	51.0	40	5
C 63	63.5	80	5
C 76	76.0	120	5