

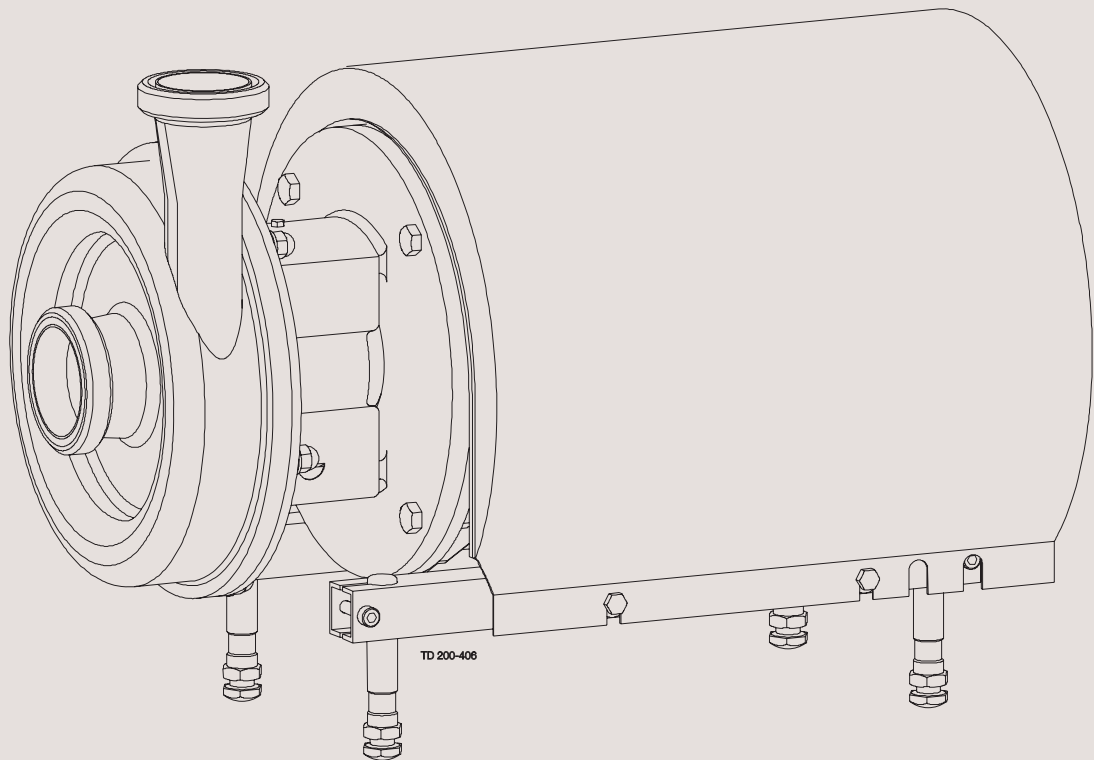

Instruction Manual

LKHI Centrifugal Pump for 16 bar Inlet Pressure



ESE00700-EN5

2015-03

Original manual

The information herein is correct at the time of issue but may be subject to change without prior notice

1. EC Declaration of Conformity	4
2. Safety	5
2.1. Important information	5
2.2. Warning signs	5
2.3. Safety precautions	6
3. Installation	7
3.1. Unpacking/delivery	7
3.2. Installation	8
3.3. Pre-use check - pump without/with impeller screw	10
3.4. Recycling information	11
4. Operation	12
4.1. Operation/Control	12
4.2. Trouble shooting	14
4.3. Recommended cleaning	15
5. Maintenance	16
5.1. General maintenance	16
5.2. Cleaning Procedure	18
5.3. Dismantling of pump/shaft seals	19
5.4. Assembly of pump/shaft seal	22
6. Technical data	25
6.1. Technical data	25
6.2. Relubrication intervals	26
6.3. Torque Specifications	29
6.4. Weight (kg)	29
6.5. Noise emission	30
7. Parts list and service kits	31
7.1. Drawings	31
7.2. LKHI - Wet end	32
7.3. LKHI - Motor dependent parts	34
7.4. LKHI - Shaft seal	36

1 EC Declaration of Conformity

Revision of Declaration of Conformity 2009-12-29

The Designated Company

Alfa Laval Kolding A/S

Company Name

Albuen 31, DK-6000 Kolding, Denmark

Address

+45 79 32 22 00

Phone No.

hereby declare that

Pump

Designation

LKHI-10, LKHI-15, LKHI-20, LKHI-25, LKHI-35, LKHI-40, LKHI-45, LKHI-50, LKHI-60

Type

From serial number 10.000 to 1.000.000

is in conformity with the following directive with amendments:

- Machinery Directive 2006/42/EC

The person authorised to compile the technical file is the signer of this document

QHSE Manager, Quality, Health and
safety & Environment

Title

Annie Dahl

Name

Kolding
Place

2013-12-03
Date



Signature



*Unsafe practices and other important information are emphasized in this manual.
Warnings are emphasized by means of special signs.
Always read the manual before using the pump!*

2.1 Important information

WARNING

Indicates that special procedures must be followed to avoid serious personal injury.

CAUTION

Indicates that special procedures must be followed to avoid damage to the pump.

NOTE

Indicates important information to simplify or clarify procedures.

2.2 Warning signs

General warning:



Dangerous electrical voltage:



Caustic agents:



2 Safety

All warnings in the manual are summarised on this page.

Pay special attention to the instructions below so that severe personal injury and/or damage to the pump are avoided.

2.3 Safety precautions

Installation:

Always read the technical data thoroughly. (See chapter 6 Technical data)

Always use a lifting crane when handling the pump.

Always remove the impeller before checking the direction of rotation.

Never start the pump if the impeller is fitted and the pump casing is removed.

Never start in the wrong direction of rotation with liquid in the pump.



Always have the pump electrically connected by authorised personnel.



Operation:

Always read the technical data thoroughly. (See chapter 6 Technical data)

Never touch the pump or the pipelines when pumping hot liquids or when sterilising.

Never run the pump with both the suction side and the pressure side blocked.

Never run the pump when partially installed or not completely assembled.

Necessary precautions must be taken if leakage occurs as this can lead to hazardous situations.



Always handle lye and acid with great care.

Never use the pump for products not mentioned in Alfa Laval pump selection program.

Alfa Laval pump selection program can be acquired from your local Alfa Laval sales company.



Maintenance:

Always read the technical data thoroughly. (See chapter 6 Technical data)

Never service the pump when it is hot.

Never service the pump if pressurized.

Always use Alfa Laval genuine spare parts.



Motors with grease nipples:

Remember lubrication according to information plate/label on the motor.

Always disconnect the power supply when servicing the pump.



Transportation:

Transportation of the pump or the pump unit:

Never lift or elevate in any way other than described in this manual

Always drain the pump head and accessories of any liquid

Always ensure that no leakage of lubricants can occur

Always transport the pump in its upright position

Always ensure that the unit is securely fixed during transportation

Always use original packaging or similar during transportation

3.1 Unpacking/delivery

Step 1



Always use a lifting crane when handling the pump.

CAUTION

Alfa Laval cannot be held responsible for incorrect unpacking.

WARNING:

Be aware that certain pump configurations can tilt, and thereby cause injuries to feet or fingers. The pump should be supported underneath the adaptor, when not installed in the process line.

Check the delivery for:

1. Complete pump.
2. Delivery note.
3. Motor instructions.

Step 2

Remove possible packing materials from the inlet and the outlet. Avoid damaging the inlet and the outlet. Avoid damaging the connections for flushing liquid, if supplied.

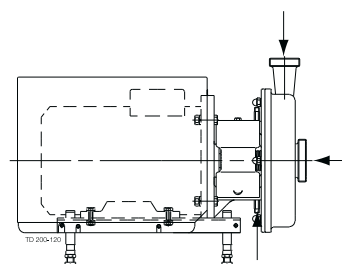

Remove packing materials!

Caution!

Step 3

Inspect the pump for visible transport damages.

Inspection!

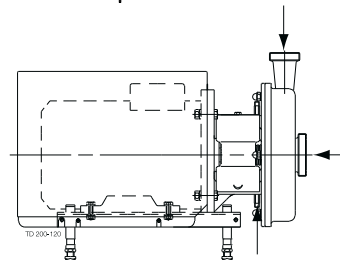

Step 4

Always remove the shroud, if fitted, before lifting the pump.

Remove the shroud before lifting!

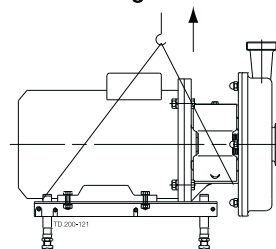

3 Installation

Study the instructions carefully and pay special attention to the warnings! Always check the pump before operation.
- See pre-use check in section 3.3 Pre-use check - pump without/with impeller screw .
The large pump sizes are very heavy.
Alfa Laval therefore recommends the use of a lifting crane when handling the pump.

3.2 Installation

Step 1



Always read the technical data thoroughly.
(See chapter 6 Technical data)



Always use a lifting crane when handling the pump.



Always have the pump electrically connected by authorised personnel. (See the motor instructions).

CAUTION

Alfa Laval cannot be held responsible for incorrect installation.

WARNING:

Alfa Laval recommend the installation of lockable repair breaker. If the repair breaker is to be used as an emergency stop the colors of the repair breaker must be red and yellow.

Caution:

The pump does not prevent back flow when intentionally or unintentionally stopped. If back flow can cause any hazardous situations precautions must be taken e.g. check valve to be installed in the system preventing above described.

Step 2

Ensure that there is sufficient clearance around the pump (min. 0.5 m) (1.6 ft).

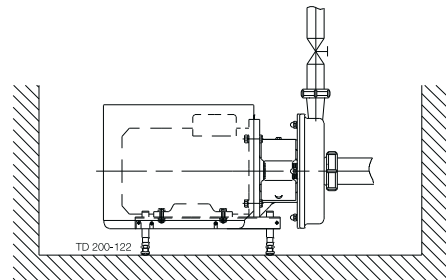

Step 3

Check that the flow direction is correct.

O: Outlet
I: Inlet

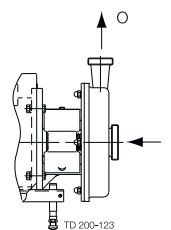

Correct!

Step 4

1. Ensure that the pipelines are routed correctly.
2. Ensure that the connections are tight.

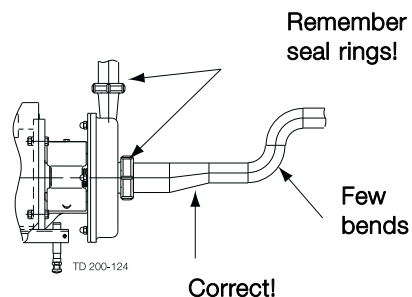

3 Installation

Study the instructions carefully and pay special attention to the warnings! Always check the pump before operation.

- See pre-use check in section 3.3 Pre-use check - pump without/with impeller screw .

The large pump sizes are very heavy.

Alfa Laval therefore recommends the use of a lifting crane when handling the pump.

Step 5

Avoid stressing the pump.

Pay special attention to:

- Vibrations.
- Thermal expansion of the tubes.
- Excessive welding.
- Overloading of the pipelines.

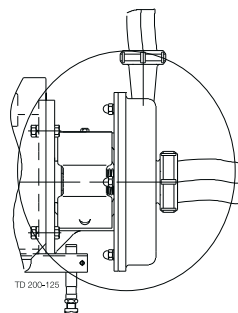

Note

In case of shaft seal leakage, the media will drip from the slot in the bottom of the adaptor. In case of shaft seal leakage, Alfa Laval recommends to put a drip tray underneath the slot for collecting the leakage.

3 Installation

Study the instructions carefully and pay special attention to the warnings!

The pump is without impeller screw as standard but can be supplied with one.

Check the direction of rotation of the impeller before operation.

- See the indication label on the pump.

3.3 Pre-use check - pump without/with impeller screw

Step 1



Always remove the impeller before checking the direction of rotation.



Never start the pump in the wrong direction of rotation with the impeller fitted.

1. Unscrew cap nuts (28) and remove washers (29) and pump casing (45).
2. Remove impeller (39) and the rotating part of the shaft seal (see also instruction 4 and 5 in section 4.2 Trouble shooting).

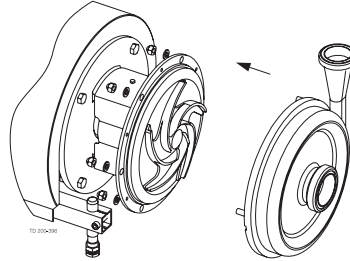

Step 2

1. Start and stop the motor momentarily.
2. Ensure that the direction of rotation of stub shaft (9) is **anticlockwise** as viewed from the inlet side.

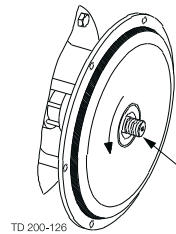

See the indication label!

Correct!

Stub shaft

Step 3

Fit and tighten impeller (39) and shaft seal.

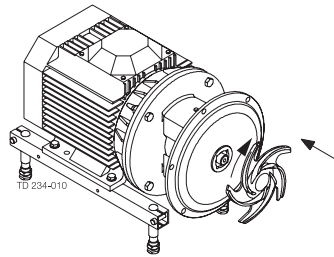

Step 4

1. Fit pump casing (45) on back plate (30).
2. Fit washers (29) and cap nuts (28) and tighten according to torque values in chapter 6 Technical data.

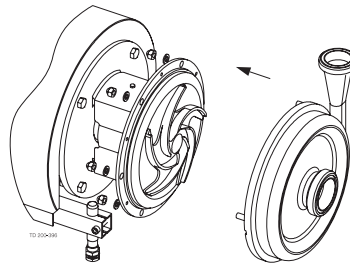

Step 1

Pre-use check - Pump with impeller screw



Never start in the wrong direction of rotation with liquid in the pump.

1. Start and stop the motor momentarily.
2. Ensure that the direction of rotation of the motor fan is **clockwise** as viewed from the rear end of the motor.

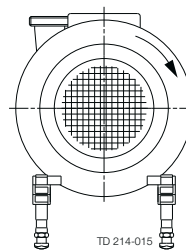

See the indication label!

Correct

View from rear end of the motor

3.4 Recycling information

- **Unpacking**

- Packing material consists of wood, plastics, cardboard boxes and in some cases metal straps.
- Wood and cardboard boxes can be reused, recycled or used for energy recovery.
- Plastics should be recycled or burnt at a licensed waste incineration plant.
- Metal straps should be sent for material recycling.

- **Maintenance**

- During maintenance oil and wear parts in the machine are replaced.
- All metal parts should be sent for material recycling.
- Worn out or defective electronic parts should be sent to a licensed handler for material recycling.
- Oil and all non metal wear parts must be taken care of in agreement with local regulations.

- **Scrapping**

- At end of use, the equipment shall be recycled according to relevant, local regulations. Beside the equipment itself, any hazardous residues from the process liquid must be considered and dealt with in a proper manner. When in doubt, or in the absence of local regulations, please contact the local Alfa Laval sales company.
-

4 Operation

Study the instructions carefully and pay special attention to the warnings!

4.1 Operation/Control

Step 1



Always read the technical data thoroughly.
See chapter 6 Technical data

CAUTION

Alfa Laval cannot be held responsible for incorrect operation/control.

Step 2



Never touch the pump or the pipelines when pumping hot liquids or when sterilising.

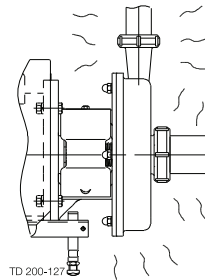

Danger of burns!



Step 3



Never run the pump with both the suction side and the pressure side blocked.

Danger of explosion!

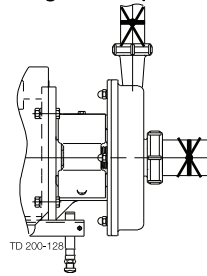

See warning label on pump.

Step 4

CAUTION!

- The shaft seal must **not** run dry.
- **Never** throttle the inlet side.

Do not allow to run dry

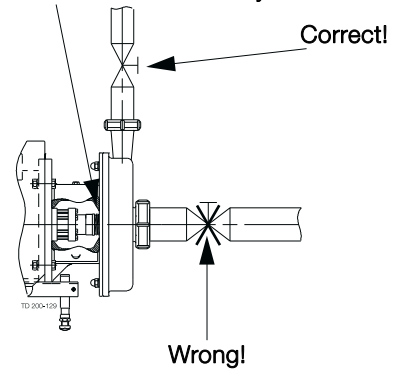

Step 5

Flushed shaft seal:

1. Connect the inlet of the flushing liquid correctly.
2. Regulate the water and steam supply correctly.
3. Observe the steam data.

O: Free outlet

I: Inlet

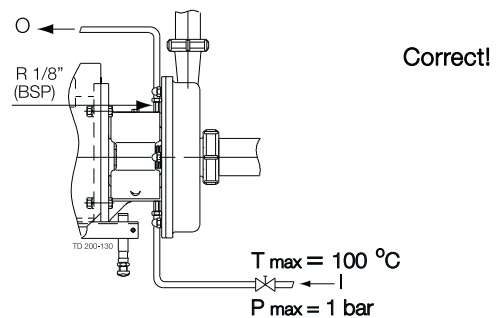

Study the instructions carefully and pay special attention to the warnings!

Step 6

Control:

Reduce the capacity and the power consumption by means of:

- Throttling the pressure side of the pump.
- Reducing the impeller diameter.
- Speed control of the motor.

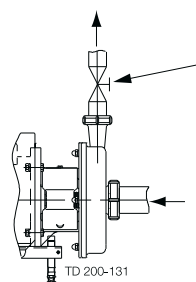

Throttling!

4 Operation

*Pay attention to possible faults.
Study the instructions carefully.*

4.2 Trouble shooting

NOTE

Study the maintenance instructions carefully before replacing worn parts.

Problem	Cause/result	Remedy
Overloaded motor	<ul style="list-style-type: none">- Pumping of viscous liquids- Pumping of liquids with high density- Low outlet pressure (counter pressure)- Lamination of precipitates from the liquid	<ul style="list-style-type: none">- Larger motor or smaller impeller- Higher counter pressure (throttling)- Frequent cleaning
Cavitation: <ul style="list-style-type: none">- Damage- Pressure reduction (sometimes to zero)- Increasing of the noise level	<ul style="list-style-type: none">- Low inlet pressure- High liquid temperature	<ul style="list-style-type: none">- Increase the inlet pressure- Reduce the liquid temperature- Reduce the pressure drop before the pump- Reduce speed
Leaking shaft seal	<ul style="list-style-type: none">- Dry run- Incorrect rubber grade- Abrasive particles in the liquid	Replace: All wearing parts If necessary: <ul style="list-style-type: none">- Select a different rubber grade- Select stationary and rotating seal ring in silicon carbide/silicon carbide
Leaking O-ring seals	Incorrect rubber grade	Change rubber grade

The pump is designed for cleaning in place (CIP). CIP = Cleaning In Place.
 Study the instructions carefully and pay special attention to the warnings!
 NaOH = Caustic Soda.
 HNO₃ = Nitric acid.

4.3 Recommended cleaning

Step 1



Always handle lye and acid with great care.

Caustic danger!



Always use
rubber gloves!



Always use
protective goggles!

Step 2



Never touch the pump or the pipelines when sterilising.

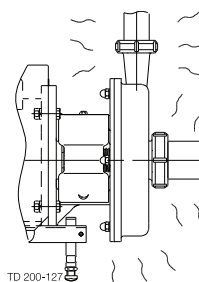

Danger of burns!



Step 3

Examples of cleaning agents: Use clean water, free from chlorides.

1. 1% by weight NaOH at 70°C (158°F).

1 kg (2.2 lb) NaOH	+	100 l (26.4 gal) water	= Cleaning agent.
-----------------------	---	---------------------------	-------------------

2.2 l (0.6 gal) 33% NaOH	+	100 l (26.4 gal) water	= Cleaning agent.
-----------------------------	---	---------------------------	-------------------

2. 0.5% by weight HNO₃ at 70°C (158°F).

0.7 l (0.2 gal) 53% HNO ₃	+	100 l (26.4 gal) water	= Cleaning agent.
---	---	---------------------------	-------------------

1. Avoid excessive concentration of the cleaning agent
 ⇒ Dose gradually!
2. Adjust the cleaning flow to the process.
 Sterilization of milk/viscous liquids
 ⇒ Increase the cleaning flow!

Step 4



Always rinse well with clean water after using a cleaning agent.

NOTE

The cleaning agents must be stored/disposed of in accordance with current regulations/directives.

Always rinse!



Water Cleaning agent

5 Maintenance

Maintain the pump carefully. Study the instructions carefully and pay special attention to the warnings!
Always keep spare shaft seals and rubber seals in stock.
See separate motor instructions.
Check the pump for smooth operation after service.

5.1 General maintenance

Step 1



Always read the technical data thoroughly.



Always disconnect the power supply when servicing the pump.

NOTE

All scrap must be stored/discharged in accordance with current rules/directives.

Step 2



Never service the pump when it is hot.

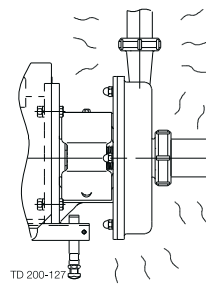

Danger of burns!

Step 3



Never service the pump with pump and pipelines under pressure.

CAUTION

Fit the electrical connections correctly if they have been removed from the motor during service.
See chapter 3.3 Pre-use check - pump without/with impeller screw
Pay special attention to the warnings!

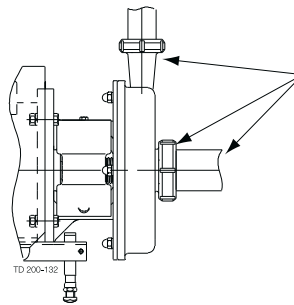

Atmospheric pressure required!

Step 4

Recommended spare parts:

Order Service kits from the Service kits list.
See chapter 7 Parts list and service kits

Ordering spare parts:

Contact your local Alfa Laval sales company.

Maintain the pump carefully. Study the instructions carefully and pay special attention to the warnings!
 Always keep spare shaft seals and rubber seals in stock.
 See separate motor instructions.
 Check the pump for smooth operation after service.

	Shaft seal	Rubber seals	Motor bearings
Preventive maintenance	Replace after 12 months: (one-shift) Complete shaft seal	Replace when replacing the shaft seal	
Maintenance after leakage (leakage normally starts slowly)	Replace at the end of the day: Complete shaft seal	Replace when replacing the shaft seal	
Planned maintenance	<ul style="list-style-type: none"> - Regular inspection for leakage and smooth operation - Keep a record of the pump - Use the statistics for planning of inspections Replace after leakage: Complete shaft seal	Replace when replacing the shaft seal	Yearly inspection is recommended <ul style="list-style-type: none"> - Replace complete bearing if worn - Ensure that the bearing is axially locked (See motor instructions)
Lubrication	Before fitting Lubricate the O-rings with silicone grease or silicone oil	Before fitting Silicone grease or silicone oil	See section 6.2 Relubrication intervals

Pre-use check

CAUTION

Fit the electrical connections correctly if they have been removed from the motor during service.
 See chapter 3.3 Pre-use check - pump without/with impeller screw

Pay special attention to the warnings!

1. Start and stop the motor momentarily.
2. Ensure that the pump operates smoothly.

5 Maintenance

5.2 Cleaning Procedure

Cleaning Procedure for Soiled Impeller Screw Tapped Hole:

1. Remove stub shaft (7) per section 4 of Service manual.
2. Submerge and soak Stub Shaft for 5 minutes in COP tank with 2% caustic wash
3. Scrub the blind tapped impeller screw hole vigorously by plunging a clean 1/2" diameter sanitary bristle pipe brush in and out of the hole for two minutes while submerged.
4. Soak Stub Shaft (7) in acid sanitizer for 5 minutes, then scrub blind tapped hole as described in step 3 above.
5. Rinse well with clean water and blow-dry blind tapped hole with clean air.
6. Swab test the inside of the tapped hole to determine cleanliness.
7. Should the swab test fail, repeat steps 2 thru 6 above until swab test is passed.

Should swab testing continue to fail, or time is of the essence, install a new (spare) Stub Shaft (7).

Study the instructions carefully.

The items refer to the drawings and the parts list on the pages 31 - .

Handle scrap correctly.

* : Relates to the shaft seal.

5.3 Dismantling of pump/shaft seals

Step 1

Unscrew cap nuts (28) and remove washers (29) and pump casing (45).

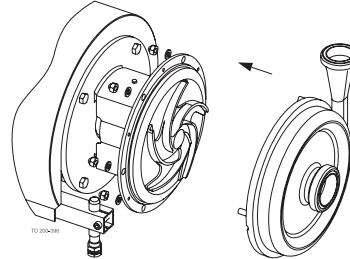

Step 2

Flushed shaft seal:

Unscrew tubes (23) using a spanner.

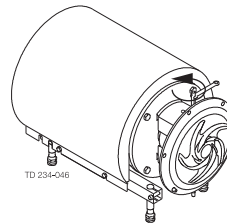

Step 3

Remove screw (14), washer (15) and safety guard (16).

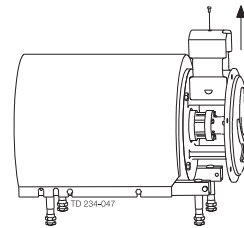

Step 4

1. If fitted, unscrew impeller screw (41) and pull off O-ring (42).
2. Remove impeller (39).
3. If necessary, loosen the impeller by tapping gently on the impeller vanes.

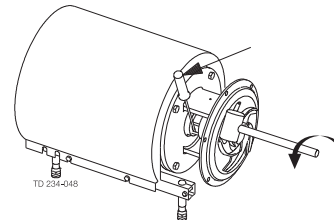

Counterhold with a screwdriver!

If necessary!

Step 5

Pull out impeller (39) and the rotating part of the shaft seal.

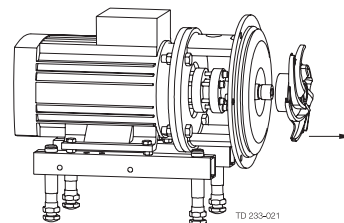

5 Maintenance

Study the instructions carefully.

The items refer to the drawings and the parts list on the pages 31 - .

Handle scrap correctly.

* : Relates to the shaft seal.

Step 6

Remove space ring (33) and the rotating part of the shaft seal from impeller (39).

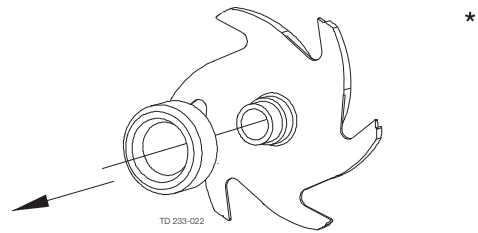

Step 7

Separate rotating seal ring (34) and quad rings (35, 38), from rotating seal housing (37).

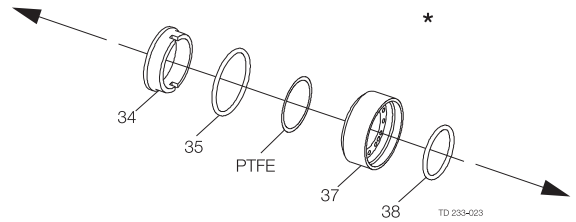

Step 8

1. Unscrew nuts (19) and remove washers (20) and back plate (30).
2. Pull off O-ring (43) from the back plate.

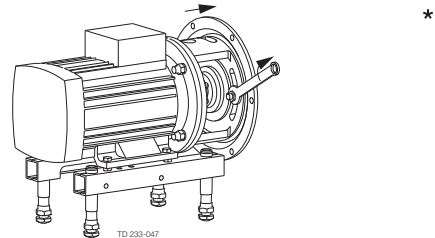

Step 9

1. Pull out stationary seal ring (32).
2. Remove O-ring (31) from the stationary seal ring.

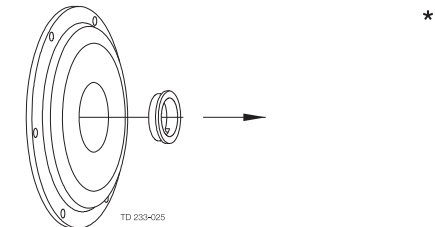

Step 10

Flushed shaft seal:

1. Remove screws (22) and seal housing (21).
2. Pull out lip seal (24) and O-ring (26) from the seal housing.
3. Slide off sleeve (27) from stub shaft (9).
4. Remove O-ring (25) from the sleeve.

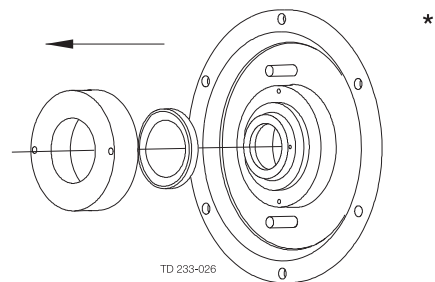

Step 11

1. Remove shroud (2).
2. Unscrew nuts (7) and remove washers (6), screws (18) and adaptor (17).

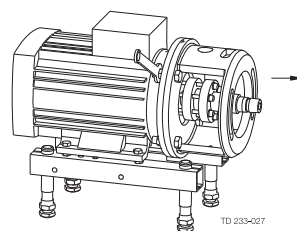

Study the instructions carefully.

The items refer to the drawings and the parts list on the pages 31 - .

Handle scrap correctly.

* : Relates to the shaft seal.

Step 12

1. Slide off stub shaft (9) together with compression rings (8, 12).

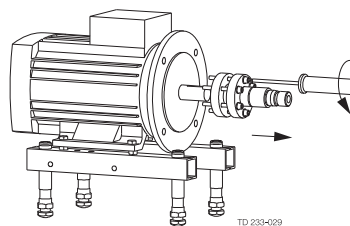

Step 13

- Separate screws (13), washers (13a) and compression rings (8, 12).

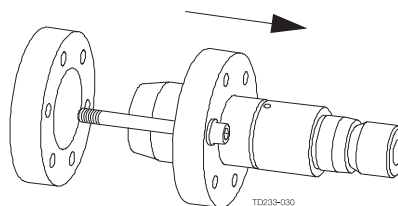

5 Maintenance

Study the instructions carefully.

The items refer to the drawings and the parts list on the pages 31 - .

Handle scrap correctly.

* : Relates to the shaft seal.

5.4 Assembly of pump/shaft seal

Step 1

1. Fit compression rings (8, 12), washers (13a) and screws (13) on stub shaft (9).
2. Slide the stub shaft onto the motor shaft.
3. Check the clearance between the end of the stub shaft and the motor flange (10-20 mm) (0.4 - 0.8 inch).

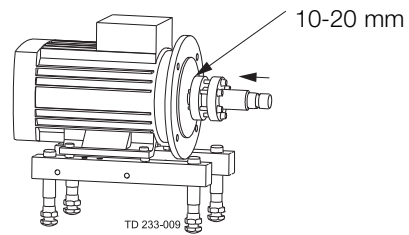

Step 2

1. Tighten screws (13) lightly and evenly.
2. Ensure that stub shaft (9) can be moved on the motor shaft.

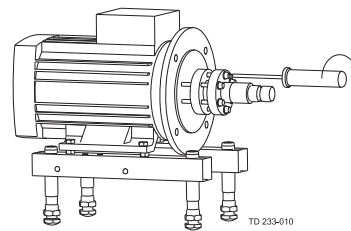

Step 3

Fit adaptor (17), screws (18), washers (6) and nuts (7) and tighten.

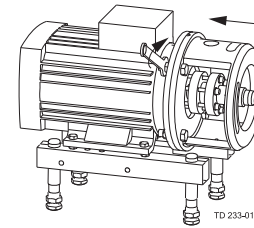

Step 4

Fit back plate (30), washers (20) and nuts (19) and tighten.

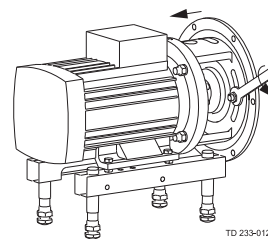

Step 5

Assemble the rotating part of the shaft seal as shown above.

CAUTION!

Ensure that the driver in the rotating seal housing (37) enters the notch in the rotating seal ring.

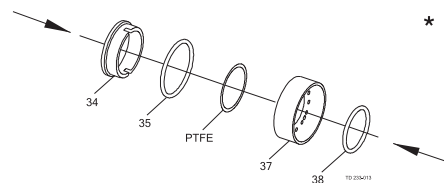

Step 6

Fit the rotating part of the shaft seal and the space ring (33) on the impeller (39).

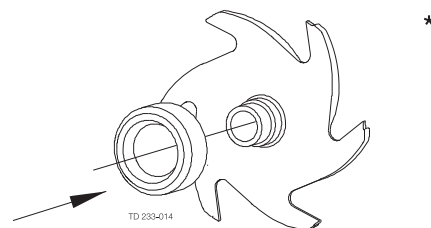

Study the instructions carefully.

The items refer to the drawings and the parts list on the pages 31 - .

Handle scrap correctly.

* : Relates to the shaft seal.

Step 7

1. Fit impeller (39) on stub shaft (9) by rotating clockwise.
2. Ensure that the clearance between the impeller and back plate (30) is 0.5 mm (0.02").

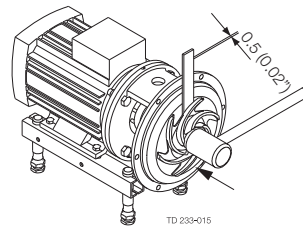

Step 8

1. Remove impeller (39) and back plate (30).
2. Tighten screws (13) evenly to 15 Nm (11 lbf-ft). Counterhold with a screwdriver

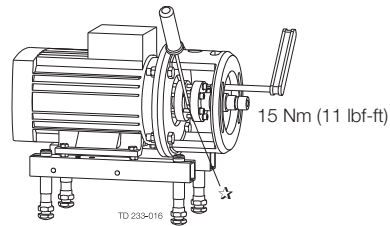

Step 9

1. Slide O-ring (31) onto stationary seal ring (32).
2. Press the stationary seal ring into back plate (30).

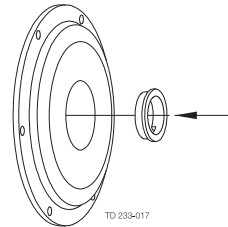

*

Step 10

Flushed shaft seal:

1. Fit lip seal (24) and O-ring (26) in seal housing (21).
 2. Fit the housing on back plate (30) and tighten the screws (22).
 3. Slide sleeve (27) with O-ring (25) onto stub shaft (9).
- Ensure that the connex pin (10) in the stub shaft (9) enters the notch in the sleeve (27).

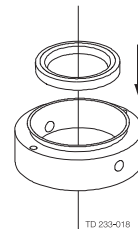

*

Step 11

1. Fit back plate (30), washers (20) and nuts (19) and tighten according to torque values in chapter 6 Technical data.
2. Fit O-ring (43) on the back plate.

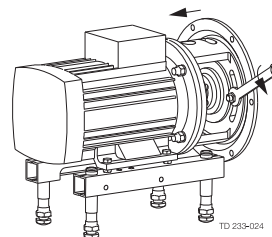

Step 12

1. Lubricate impeller hub (39) with silicone grease or oil.
2. Screw the impeller onto stub shaft (9).
3. If used, fit O-ring (42) and impeller screw (41).

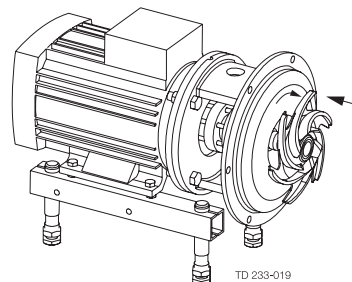

5 Maintenance

Study the instructions carefully.

The items refer to the drawings and the parts list on the pages 31 - .

Handle scrap correctly.

* : Relates to the shaft seal.

Step 13

1. Fit pump casing (45).
2. Fit washers (29) and cap nuts (28) and tighten according to torque values in chapter 6 Technical data.

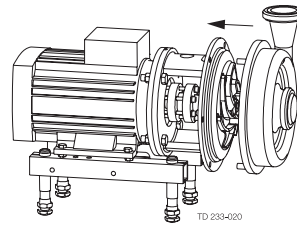

Step 14

1. Mount shroud (2).
2. Position safety guard (16), washer (15) and screw (14) and tighten.

If pump is not supplied with flush connections the holes in the adaptor shall be covered by the guard.

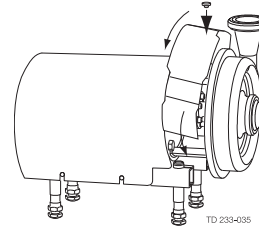

Step 15

Flushed shaft seal:

Fit tubes (23) in seal housing (21).

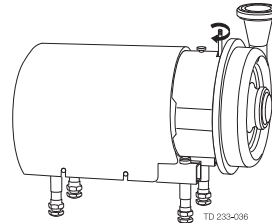

*It is important to observe the technical data during installation, operation and maintenance.
Inform personnel about the technical data.*

6.1 Technical data

The LKHI pump is highly efficient and economical centrifugal pump, specially designed for inlet pressures up to 16 bar. LKHI meets the requirements of sanitary and gentle product treatment and chemical resistance, and is available in the following sizes. LKHI -10, -15, -20, -25, -35, -40, -45, -50, -60. The instruction manual is part of the delivery. Study the instructions carefully. The large pump sizes are very heavy. Alfa Laval therefore recommends the use of a lifting crane when handling the pump.

Data			
Max. inlet pressure	1600 kPa	(16 bar)	(232 psi)
Temperature range	-10° C to +140° C	(EPDM)	(14 to 284°F)
Max. speed:	4000 rpm		
Materials			
Product wetted steel parts	AISI 316L		
Other steel parts	Stainless steel		
Finish	Semi-bright		
Product wetted seals	EPDM (standard)		
Other O-rings	EPDM		
Alternative seals	Nitrile (NBR), Fluorinated rubber (FPM)		
Shaft seal			
Seal types	Single internal or flushed seal		
Max. temperature flush media	70°C		
Max. water pressure (flushed seal)	Normally atmospheric	(max. 1 bar)	(max. 14.5 psi)
Water consumption (flushed seal)	0.25 - 0.5 l/min.	(0.07-0.13 gpm)	
Material, stationary seal ring	Silicon carbide		
Material, rotating seal ring	Carbon (standard) or silicon carbide		
Material, O-rings	EPDM (standard)		
Material comb.	Silicon carbide/carbon or silicon carbide/silicon carbide		
Motor			
Foot-flanged motor acc. to IEC metric standard			
2 poles = 3000/3600 rpm. at 50/60 Hz			
IP55 (with drain hole sealed with plug), insulation class F			
Motor types:	<ul style="list-style-type: none"> - Standard motor with ball bearings - Special motor with a fixed angular-contact ball bearing on drive side 		
Inlet pressure 0-10 bar	Standard motor		
Inlet pressure 10-16 bar	Special motor		
NOTE! The special motor must be ordered for inlet pressure 10-16 bar			
Motor sizes (kW), 50 Hz, 400 V	1.5 - 30 kW		
Motor sizes (kW), 60 Hz, 440 V	1.75 - 35 kW		

For further information - see PD sheet.

6 Technical data

It is important to observe the technical data during installation, operation and maintenance.
Inform the personnel about the technical data.

6.2 Relubrication intervals

The table is for an internal bearing temperature of 100°C. An increase in temperature of 15°C (ambient or internal in bearings), will reduce the greasing interval and bearing lifetime by 50%. The lubrication interval for vertically mounted pumps is half the value stated in the table.

ABB IEC motors, IE3

Motor power (kW)	LKH5 -90 LKH110 -60* LKH-110* LKHSP LKH UltraPure 50/60 Hz	LKHPF-10 -60 LKH1-10 -60 LKH-110 3300 Bearing 50/60 Hz	LKHPF-70 LKH-120 7200 Bearing 50/60 Hz	LKH-85 7300 Bearing 50/60 Hz
0.75	Permanently lubricated			
1.1	Permanently lubricated			
1.5	Permanently lubricated	Not available		
2.2	Permanently lubricated	Permanently lubricated		
3.0	Permanently lubricated	Not available		
4.0	Permanently lubricated	Permanently lubricated		
5.5	Permanently lubricated	3600h/3000h - DE/NDE:15g*		
7.5	Permanently lubricated	3600h/3000h - DE/NDE:15g*		
11	Permanently lubricated	3100h/2300h - DE/NDE:25g		
15	Permanently lubricated	3100h/2300h - DE/NDE:25g		
18.5	Permanently lubricated	3100h/2300h - DE/NDE:25g		
22	Permanently lubricated	2600h/2000h - DE/NDE:42g	4000h/2200h - DE/NDE:42g	
30	Permanently lubricated		4000h/2800h - DE/NDE:55g	8000h/ - - DE/NDE:40g
37	Permanently lubricated		4000h/2800h - DE/NDE:55g	8000h/ - - DE/NDE:40g
45	Permanently lubricated		2500h/1000h - DE/NDE:55g	8000h/ - - DE/NDE:40g
55	Permanently lubricated		2500h/1000h - DE/NDE:73g	8000h/3000h - DE/NDE:60g
75	Permanently lubricated		1500h/500h - DE/NDE:73g	4000h/1500h - DE/NDE:60g
90				4000h/2800h - DE/NDE:45g
110				4000h/2800h - DE/NDE:45g

* inlet pressure less than 10 bar (145 psi)

Recommended grease types:

LKHPF-10/-70 – LKH-110 - LKH-120:

Esso: Unirex N2 or N3 (Lithium complex base)
Mobil: Mobilith SHC 100 (Lithium complex base)
Shell: Shell Gadus S5 V100 2 (Lithium complex base)
Klüber: Klüberplex BEM 41-132 (Special Lithium base)
FAG: Arcanol TEMP110 (Lithium complex base)
Lubcon: Turmogrease L 802 EP PLUS (Lithium complex base)

*LKHPF-10/-60 – LKH-110

Klüber: Klüber Asonic HQ72-102 (Polyurea base)

LKH-85:

Klüber: Klüberplex Quiet BQH 72-102 (Polyurea base)
Lubcon: Turmogrease PU703 (Polyurea base)

WARNING: Polyurea-based grease must not be mixed with Lithium complex base grease and vice versa.

*It is important to observe the technical data during installation, operation and maintenance.
Inform the personnel about the technical data.*

WEG IEC Motors, IE3

Motor power (kW)	LKH-5 -70 LKHI-10 -60* LKH-110* LKHSP, LKH Evap LKH UltraPure 50/60 HZ
0.75	Permanently lubricated
1.1	Permanently lubricated
1.5	Permanently lubricated
2.2	Permanently lubricated
3.0	Permanently lubricated
4.0	Permanently lubricated
5.5	Permanently lubricated
7.5	Permanently lubricated
11	Permanently lubricated
15	Permanently lubricated
18.5	Permanently lubricated
22	10000/10000h - DE/NDE: 18g
30	10000/10000h - DE/NDE: 21g
37	10000/10000h - DE/NDE: 21g
45	Not available
55	5000/5000h - DE/NDE: 27g
75	5000/5000h - DE/NDE: 27g

* inlet pressure < 10 bar (145 psi)

Recommended grease types:

Mobil POLYREX EM 103

6 Technical data

*It is important to observe the technical data during installation, operation and maintenance.
Inform the personnel about the technical data.*

Table 1. Sterling Nema motors

Motor RPM	Frame VS. HP	Type of service Standard 8 hrs/day	Heavy duty 24 hrs/day
3600	143T - 286TS 1.5 - 30	*	*
	324TS - 455TS 40 - 150	6 Months	2 Months
1800	143T - 256T 1 - 20	*	*
	284T - 326T 25 - 50	4 Months	18 Months
	364T - 445T 60 - 150	9 Months	3 Months
1200	143T - 256T 0.75 - 10	*	*
	284T - 326T 15 - 30	4 Years	16 Years
	364T - 445T 40 - 125	1 Year	4 Months

* Motor of this size normally do not have bearings that can be re-lubricated.
These bearings should be replaced at least every 5 years for 8 hr/day service, or every 2 years for 24 hr/day service.

Warning: Bearing grease is Klüber NBU-15 - DO NOT SUBSTITUTE!

6 Technical data

*It is important to observe the technical data during installation, operation and maintenance.
Inform the personnel about the technical data.*

6.3 Torque Specifications

Below table specifies the tightening torques for the screws, bolts and nuts in this pump.
Always use below torques if no other values are stated. This can be a matter of personal safety.

Size	Tightening torque	
	Nm	lbf-ft
M8	20	14.8
M10	40	29.5
M12	67	49.0
M14	110	81.0

6.4 Weight (kg)

Pump Type: LKHI

Size	Motor										
	90		100	112	132		160		180	200	
	1.5kW	2.2kW	3kW	4kW	5.5kW	7.5kW	11kW	15kW	18.5kW	22kW	30kW
10	53	55	70	75							
15			73	78	95						
20	55	57	72	77	94	108					
25				81	98	112	171	185			
35				81	98	112	171	185			
40						115	174	188	206	225	
45				82	99	113	172	186			
50					101	115	174	188	206	225	
60					102	116	175	189	207	226	334

Weight can vary depending of configuration. Weight is only to be seen as a reference value during handling, transporting and packaging.

6 Technical data

*It is important to observe the technical data during installation, operation and maintenance.
Inform the personnel about the technical data.*

6.5 Noise emission

Pump Type	Sound pressure level (dBA)
LKH-5	60
LKH-10	69
LKH-15	72
LKH-20	70
LKH-25	74
LKH-35	71
LKH-40	75
LKH-45	70
LKH-50	75
LKH-60	77
LKH-70	88
LKH-75	79
LKH-85	86
LKH-90	75
LKH-112	70
LKH-113	69
LKH-114	68
LKH-122	75
LKH-123	77
LKH-124	80
SolidC-1	68
SolidC-2	72
SolidC-3	73
SolidC-4	72
MR-166	76
MR-185	82
MR-200	81
MR-300	82
GM	54
FM-OS	61

The above LKH noise levels are the same for LKHDPF, LKHDI, LKH UltraPure, LKH Evap, LKHHex
The above SolidC noise levels are the same for SolidC UltraPure

The noise measurements have been carried out with original motor and shroud, approximately at the Best Efficiency Point (BEP) with water at ambient temperature and at 50 Hz.

Very often the noise level generated by the flow through the process system (e.g. valves, pipes, tanks etc.) is much higher than what is generated by the pump itself. Therefore it is important to consider the noise level from the total system and take the necessary precautions with regards to personal safety if required.

7 Parts list and service kits

The drawing shows LKHI pump, sanitary version.

7.1 Drawings

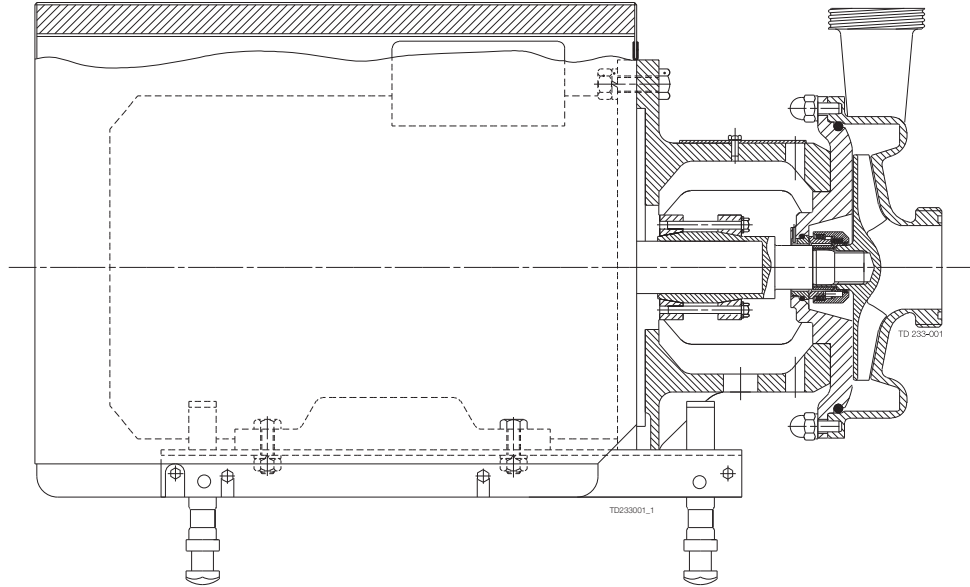

US legs are different to the ones shown. For further information see US Spare part.

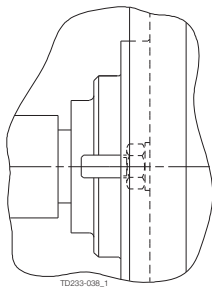

Fitting of back plate

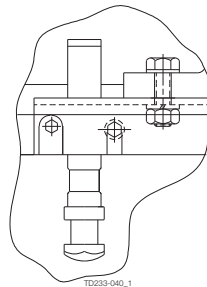

Only used for 5.5 - 30 kW

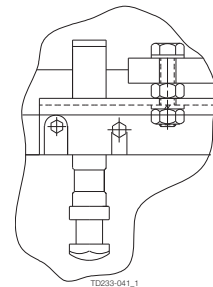

Fitting of legs
Only used for 3 kW

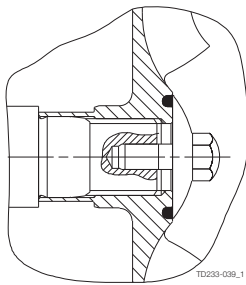

Impeller screw

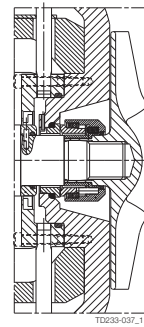

Flushed shaft seal

7 Parts list and service kits

The drawing shows LKHI pump, sanitary version.

7.2 LKHI - Wet end

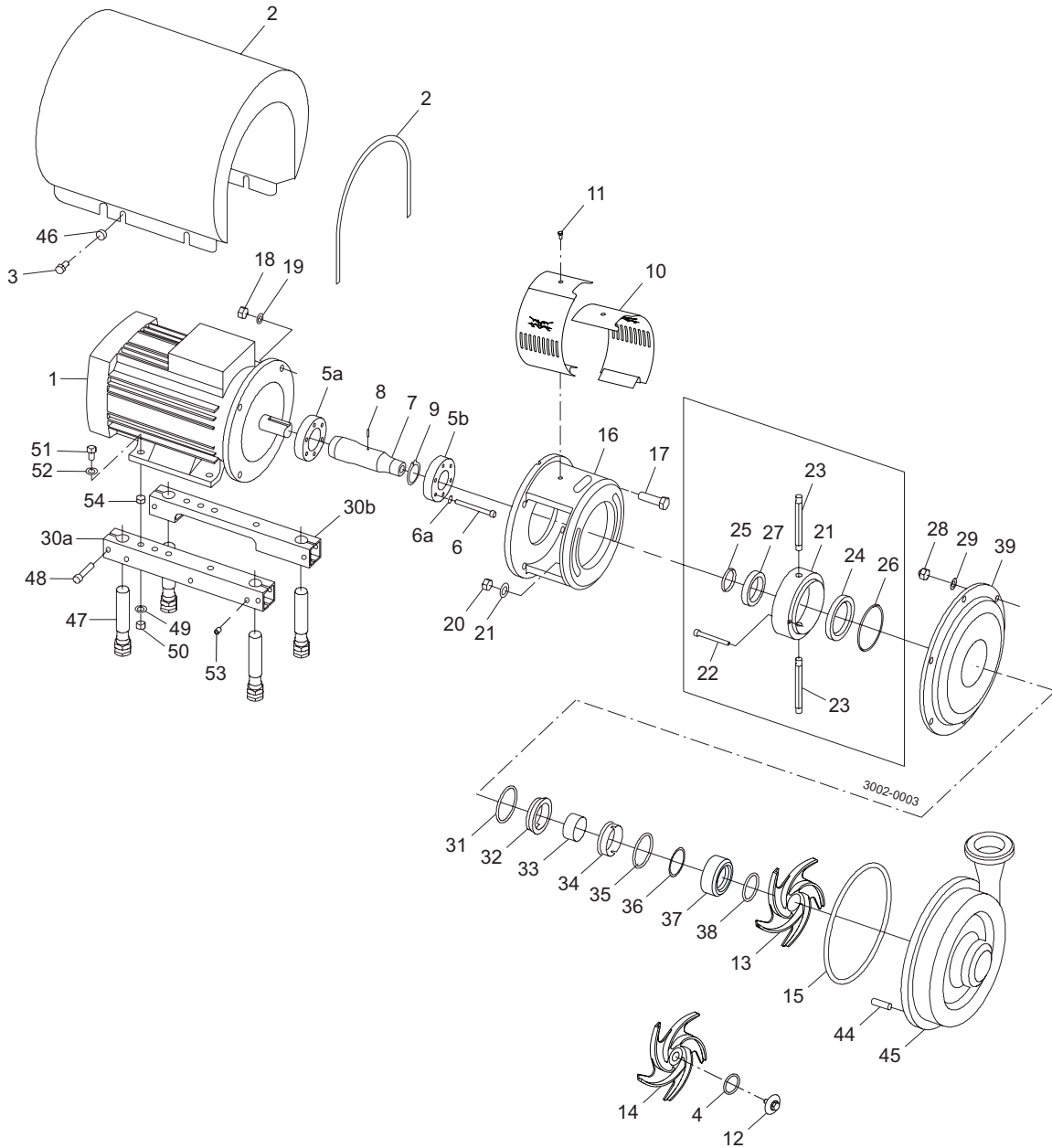

7 Parts list and service kits

The drawing shows LKHI pump, sanitary version.

Parts list

Pos.		Qty	Denomination
4	○■●◎	1	O-ring
12		1	Impeller screw
13		1	Impeller
14		1	Impeller for impeller screw
15	□◆○◇◆■ ●◎	1	O-ring
20		2	Nut
21		2	Washer
28		6	Cap nut
29		6	Washer
39		1	Back plate
44		6	Bolt
45		1	Pump casing

7 Parts list and service kits

The drawing shows LKHI pump, sanitary version.

7.3 LKHI - Motor dependent parts

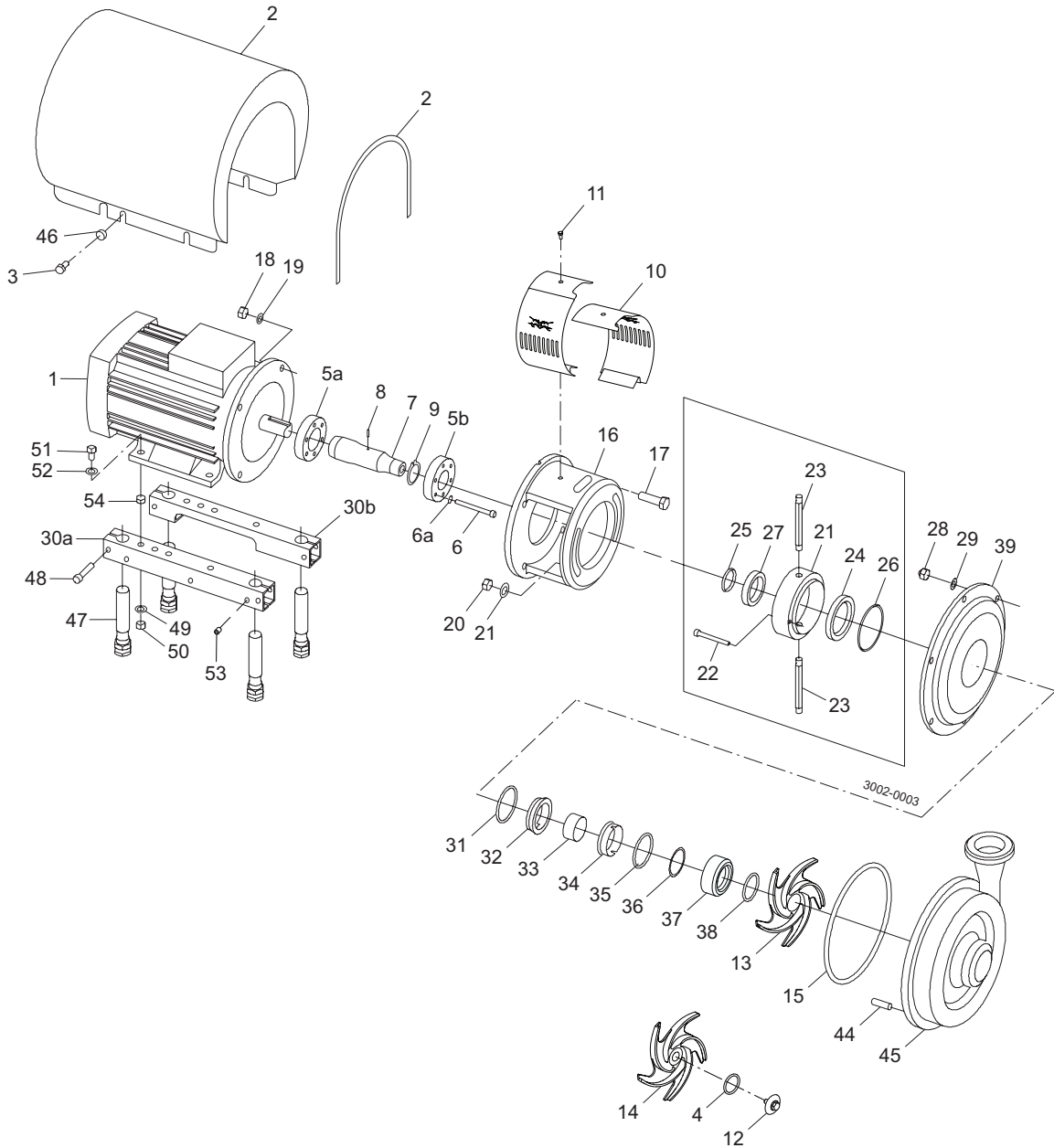

7 Parts list and service kits

The drawing shows LKHI pump, sanitary version.

Parts list

Pos.	Qty	Denomination
1	1	Motor ABB
2	1	Shroud
3	4	Screw
5a	1	Compression ring with thread
5b	1	Compression ring without thread
6	6	Screw
6a	6	Washer
7	1	Shaft incl. pin
8	1	Connex pin
9	1	Retaining ring
10	1	Safety guard set
11	1	Screw for safety guard
16	1	Adaptor
17	4	Screw for adaptor
18	4	Nut for adaptor
19	4	Washer for adaptor
30a	1	Support bar
30b	1	Support bar, left
46	4	Distance sleeve
47	4	Leg
48	4	Screw
49	4	Spring washer
50	4	Nut
51	4	Screw
52	4	Washer
53	4	Pivot screw
54	4	Nut

7 Parts list and service kits

The drawing shows LKHI pump, sanitary version.

7.4 LKHI - Shaft seal

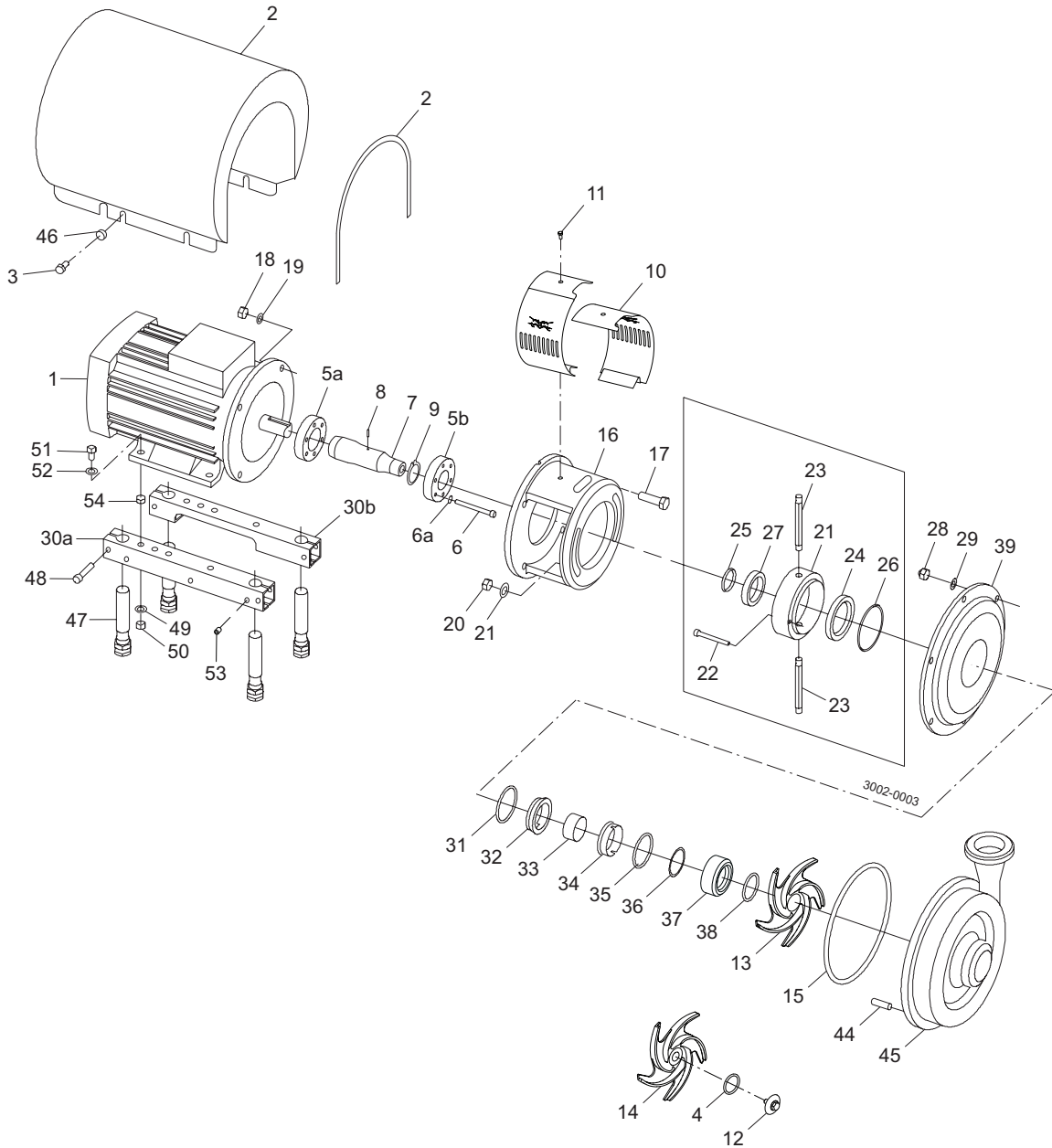

7 Parts list and service kits

The drawing shows LKHI pump, sanitary version.

Parts list

Pos.	Qty	Denomination
□○		Single shaft seal
◆●		Single shaft seal
◆■		Flushed shaft seal
◆◎		Flushed shaft seal
21	1	Seal housing
22	2	Screw
23	2	Tube
24	1	Lip seal
25	1	O-ring
26	1	O-ring
27	1	Sleeve
33	1	Spacing ring
37	1	Rotating seal housing

Service kits

Denomination	EPDM	NBR	FPM
Service kit for single shaft seal C/SIC (0-10 bar)			
□ Service kit, C/SIC (LKH-10/15)	9611922254	9611922255	9611922256
□ Service kit, C/SIC (LKH-20)	9611922266	9611922267	9611922268
□ Service kit, C/SIC (LKH-25/35/45)	9611922278	9611922279	9611922280
□ Service kit, C/SIC (LKH-40/50/60)	9611922290	9611922291	9611922292
Service kit for single shaft seal SIC/SIC (0-16 bar)			
◆ Service kit, SIC/SIC (LKH-10/15)	9611922139	9611922140	9611922141
◆ Service kit, SIC/SIC (LKH-20)	9611922151	9611922152	9611922153
◆ Service kit, SIC/SIC (LKH-25/35/45)	9611922194	9611922195	9611922196
◆ Service kit, SIC/SIC (LKH-40/50/60)	9611922163	9611922164	9611922165
Service kit for single shaft seal and impeller screw C/SIC (0-10 bar)			
○ Service kit, C/SIC (LKH-10/15)	9611922257	9611922258	9611922259
○ Service kit, C/SIC (LKH-20)	9611922269	9611922270	9611922271
○ Service kit, C/SIC (LKH-25/35/45)	9611922281	9611922282	9611922283
○ Service kit, C/SIC (LKH-40/50/60)	9611922293	9611922294	9611922295
Service kit for single shaft seal and impeller screw SIC/SIC (0-16 bar)			
● Service kit, SIC/SIC (LKH-10/15)	9611922142	9611922143	9611922144
● Service kit, SIC/SIC (LKH-20)	9611922154	9611922155	9611922156
● Service kit, SIC/SIC (LKH-25/35/45)	9611922197	9611922198	9611922199
● Service kit, SIC/SIC (LKH-40/50/60)	9611922166	9611922167	9611922168
Service kit for flushed shaft seal C/SIC (0-10 bar)			
◆ Service kit, C/SIC (LKH-10/15)	9611922260	9611922261	9611922262
◆ Service kit, C/SIC (LKH-20)	9611922272	9611922273	9611922274
◆ Service kit, C/SIC (LKH-25/35/45)	9611922284	9611922285	9611922286
◆ Service kit, C/SIC (LKH-40/50/60)	9611922296	9611922297	9611922298
Service kit for flushed shaft seal SIC/SIC (0-16 bar)			
◆ Service kit, SIC/SIC (LKH-10/15)	9611922145	9611922146	9611922147
◆ Service kit, SIC/SIC (LKH-20)	9611922157	9611922158	9611922159
◆ Service kit, SIC/SIC (LKH-25/35/45)	9611922200	9611922201	9611922202

7 Parts list and service kits

The drawing shows LKHI pump, sanitary version.

Denomination	EPDM	NBR	FPM
◇ Service kit, SIC/SIC (LKH-40/50/60)	9611922169	9611922170	9611922171
Service kit for flushed shaft seal and impeller screw C/SIC (0-10 bar)			
■ Service kit, C/SIC (LKH-10/15)	9611922263	9611922264	9611922265
■ Service kit, C/SIC (LKH-20)	9611922275	9611922276	9611922277
■ Service kit, C/SIC (LKH-25/35/45)	9611922287	9611922288	9611922289
■ Service kit, C/SIC (LKH-40/50/60)	9611922299	9611922300	9611922301
Service kit for flushed shaft seal and impeller screw SIC/SIC (0-16 bar)			
⊙ Service kit, SIC/SIC (LKH-10/15)	9611922148	9611922149	9611922150
⊙ Service kit, SIC/SIC (LKH-20)	9611922160	9611922161	9611922162
⊙ Service kit, SIC/SIC (LKH-25/35/45)	9611922203	9611922204	9611922205
⊙ Service kit, SIC/SIC (LKH-40/50/60)	9611922172	9611922173	9611922174

Parts marked with □◆◇◆■●⊙ are included in the service kits. Recommended spare parts: Service kits,^(900601/5)

Conversion kit single to flushed shaft seal : Please order Flushed service kit + pos. 40 + 41 + 42

How to contact Alfa Laval

Contact details for all countries are continually updated on our website.

Please visit www.alfalaval.com to access the information directly.

© Alfa Laval Corporate AB

This document and its contents is owned by Alfa Laval Corporate AB and protected by laws governing intellectual property and thereto related rights. It is the responsibility of the user of this document to comply with all applicable intellectual property laws. Without limiting any rights related to this document, no part of this document may be copied, reproduced or transmitted in any form or by any means (electronic, mechanical, photocopying, recording, or otherwise), or for any purpose, without the expressed permission of Alfa Laval Corporate AB. Alfa Laval Corporate AB will enforce its rights related to this document to the fullest extent of the law, including the seeking of criminal prosecution.