

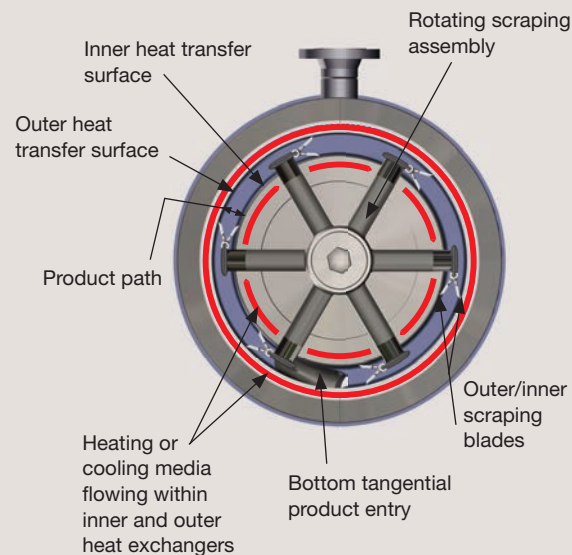

Contherm Max scraped-surface heat exchanger

Double-wall design offers high capacity and small footprint



Design

The Contherm Max double-wall scraped-surface heat exchanger (SSHE) features 4.5 times more surface area than the largest traditional-size Contherm. The Contherm Max utilizes both an inner and outer heat transfer surface, ensuring a low-shear 2-inch (51 mm) product path.

The highly engineered scraping cage assembly and blades minimize the power required to achieve effective scraping.

The Contherm Max is a stand-alone unit that only takes up a small amount of space, because it is installed vertically, and does not need to be fixed to adjacent structures such as a wall or ceiling.

Features and benefits compared with other scraped-surface heat exchangers

- Large surface area with capacity equivalent to three traditional-size scraped surface heat exchangers
- Low pressure drop and low shear environment that ensure gentle treatment for shear-sensitive or particulate products
- One single mechanical seal per unit, resulting in significant savings on maintenance costs
- Small footprint, with no need for significant rigging – thus reducing installation costs

Applications

The Contherm Max is ideal for applications that require high throughput as well as the uniform heat transfer of viscous, sticky and heat sensitive products that would tend to foul other types of non-scraped heat exchangers.

The unique design of the Contherm Max and the product path created by the two heat transfer walls make it particularly suitable for high-quality products that require low shear or contain large particulate pieces.

This makes these heat exchangers well-suited for use in the manufacture of a wide variety of prepared foods such as soups, sauces, starch-based condiments, baby food, desserts, fruit, vegetable purées and concentrates with or without particles, confectionery creams, cream cheese and spreadable cheese products.

Examples of non-food uses can include pet food and personal care products such as skin creams, lotions, gels, petroleum jelly and shampoo.

Application	Contherm [®] Max	Contherm [®] Traditional-size SSHE
Throughput capacity per units	■ ■ ■ ■ ■	■ ■
Particulate processing	■ ■ ■ ■ ■	■ ■ ■ ■ ■
Low shear, gentle treatment	■ ■ ■ ■ ■	■ ■ ■ ■ ■
Thermal efficiency per area	■ ■ ■	■ ■ ■ ■ ■
Viscosity	■ ■	■ ■ ■ ■ ■
Rapid, flexible product transitions	■ ■	■ ■ ■ ■ ■

How it works

Product enters at the bottom tangential entry port, and exits at the top of the Contherm Max. Steam or liquid heating or cooling media flow from top to bottom in a counter-current path at high velocity, in order to optimize heat transfer to the product.

A highly engineered rotating scraping assembly, fitted with blades that continuously remove fouling material from both inner and outer walls, is mounted within the product path. The rotating scraping assembly can vary in speed to ensure the most effective scraping and best product quality.

At the end of production, the product can be drained or removed by water, resulting in minimal product loss. The Contherm Max can then be Cleaned in Place (CIP) using recommended guidelines for cleaning.



Equipment specifications

Mechanical design	Surface area	Maximum product pressure	Maximum media pressure	Maximum temperature rating	Number of seals/blades per unit	Hold-up volume	Mounting
Contherm [®] Max	4.5 m ² 48 sq ft ²	15 Bar/ 220 psi	8 Bar/ 115 psi	150°C/ 302°F	1/48	130 liter/ 34.5 gal	Vertical
Contherm [®] Traditional size SSHE	0.56-1 m ² / 6-11 sq ft ²	27 Bar/ 397 psi	17 Bar/ 250 psi	170°C/ 338°F	2/up to 16	29 liter/ up to 8 gal	Vertical or horizontal

- Heat transfer surfaces made of 316L stainless steel
- Scraping blades made of ALFA-LON III FDA- and EU-compliant material.
- Single or flushed (aseptic) mechanical seal assembly
- Connections:
Product – 4" (102 mm)
Outer Media – 3" (76 mm) Flange
Inner Media – 1½" (38 mm) Flange
- 20 HP (15 kW), 3-phase, 50/60 Hz, 400/460 volt motor
Frequency inverters are recommended to optimize thermal efficiency and product quality

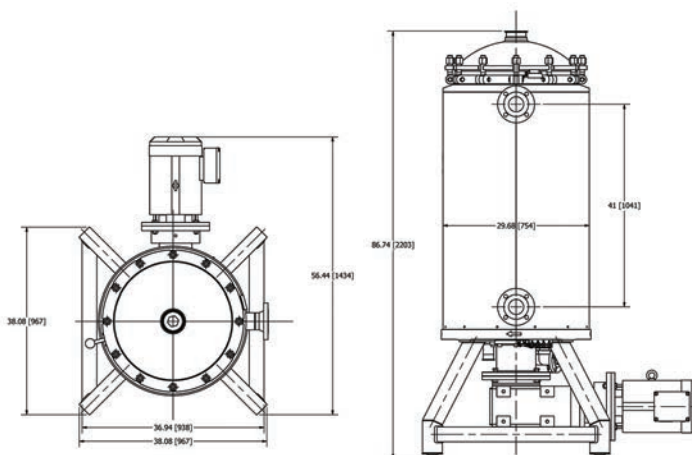

Alfa Laval reserves the right to change specifications without prior notification.

How to contact Alfa Laval

Up-to-date Alfa Laval contact details for all countries are always available on our website at www.alfalaval.com