



Avoid Particles in your Liquid

LKVF Coarse Strainer

PD 65145 GB3 2002-02

Application

LKVF has a wide range of applications where removal of particles from a flow is required, eg. for protection of a pump or other sensible equipment.

Working principle

It is recommended to use the end connection (A) as inlet and the side connection (B) as outlet, see fig. 1. This means that the particles strained off will gather inside the filter element which facilitates cleaning, especially if the handle points downwards or if the strainer is horizontally installed. However, both flow directions may be used as the perforated tube is designed for withstanding the pressure drop for both flow directions. If side connection (B) is used as inlet max. product pressure is 7 bar.

Standard design

The strainer consists of a casing with inlet and outlet. Inside the casing the filter element is fixed so that the flow is forced through it. This element consists of a perforated tube which is welded to a flange with a handle. This flange fits a ferrule on the casing to which it is clamped.

Materials

Product wetted steel parts:	Acid-resistant steel AISI 316.
Other steel parts:	Stainless steel AISI 304.
Seals:	EPDM rubber.
Surface finish:	Semi bright.

Sizes

25mm (1"), 38mm (1½"), 51 (2"), 63.5mm (2½") and 76.1mm (3").

Technical data

Max. product pressure (A=inlet):	1000 kPa (10 bar).
Max. product pressure (B=inlet):	700kPa (7 bar).
Min. product pressure:	Full vacuum.
Temperature range:	-10°C to 140°C (EPDM)
Strainer area:	
25-38-51 mm:	430 cm ² .
63.5-76.1 mm:	840 cm ² .

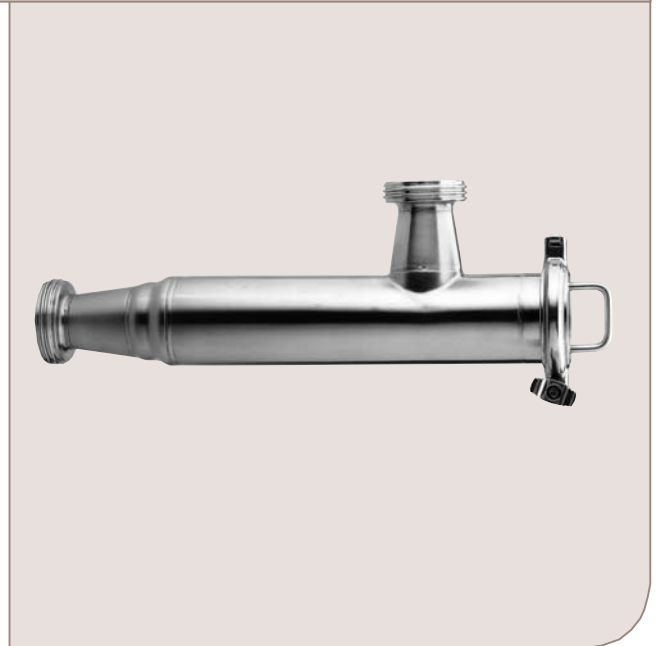

Fig. 1. LKVF, coarse strainer.

Pressure drop / capacity diagram

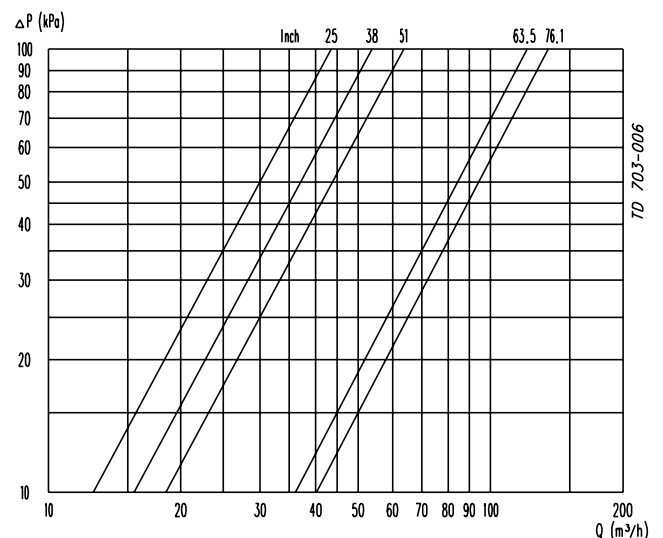

Fig. 2. LKVF with ø2 mm holes in filter element.
Medium: Water (20°C).

Strainer element perforation (mm)

d	C	Perforation
1	2	23%
2	3.5	30%
3	5	33%

Dimensions (mm)

Size	25 mm	38 mm	51 mm	63.5 mm	76.1 mm
A	419	375	333	460	421
B	288	244	202	352	313
OD	25	38	51	63.5	76.1
ID	22.6	35.6	48.8	60.3	72.1
t	1.2	1.2	1.1	1.6	2
E	121	77	77	94	94
M/DS male	18.5	20	20	24	24
M/SMS male	15	20	20	24	24
M/ISO male	21.5	21.5	21.5	21.5	21.5
M/BS male	22	22	22	22	22
M/DIN male	22	22	22	25	30
M/ISO clamp	21.5	21.5	21.5	21.5	
Weight (kg)	1.5	1.5	1.5	3.7	3.7

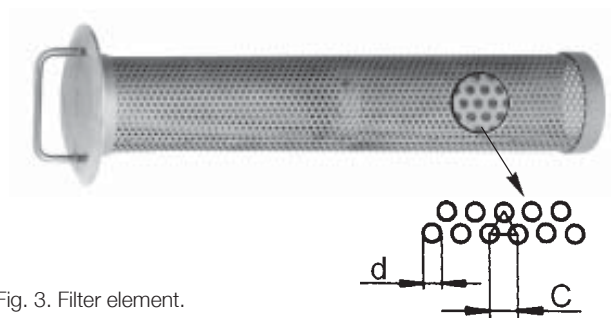

Fig. 3. Filter element.

Options

Material grades

A) Seal of Nitrile (NBR) or PTFE.

Ordering

Please state the following when ordering:

- Size.
- Connections if not welding ends.
- Size of holes in straining element, 1, 2 or 3 mm.
- Options.

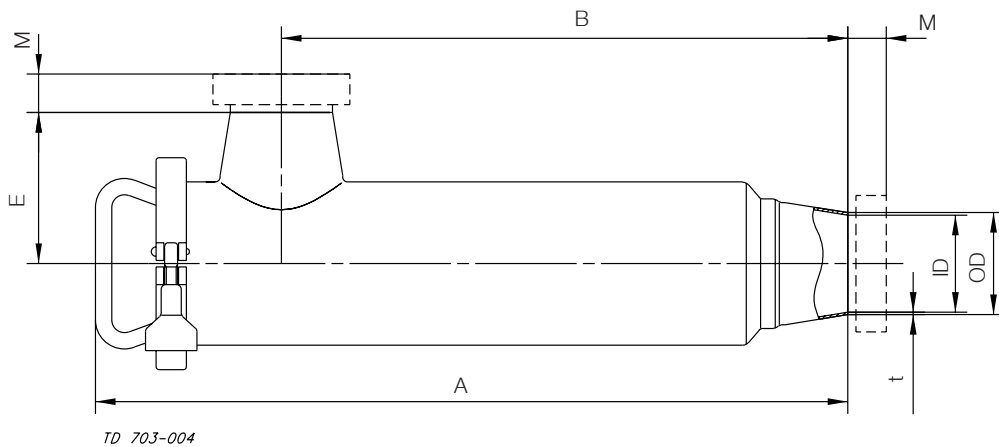

TD 703-004

Fig. 4. Dimensions.

How to contact Alfa Laval

Contact details for all countries are continually updated on our website. Please visit www.alfalaval.com to access the information direct.