

Control the Pressure of your System

CPM Constant-Pressure Modulating Valve

Application

CPMI-2, CPMI-D60 and CPMO-2 are sanitary constant-pressure valves for use in stainless steel pipe systems.

CPMI-2 and CPMI-D60 (Constant-Pressure Modulating Inlet) maintain a constant pressure in the process line at the inlet side of the valve. Typical applications of CPMI-2 and CPMI-D60 are after separators, heat exchangers etc. and as overflow valves.

CPMO-2 (Constant-Pressure Modulating Outlet) maintains a constant pressure in the process line at the outlet side of the valve. Typical applications of CPMO-2 are before filling/bottling machines etc.

Working principle

CPMI-2, CPM-I-D60 and CPMO-2 are remote-controlled by means of compressed air. The valves operate without a transmitter in the product line and require only a pressure regulating valve for the compressed air and a pressure gauge in the product line (see fig. 5).

A diaphragm/valve plug system reacts immediately to any alteration of the product pressure and changes position so that the preset pressure is maintained.

CPMI-2 and CPM-I-D60 open at increasing product pressure and vice versa. CPMO-2 closes at increasing product pressure and vice versa (see fig. 3).

Standard design

The CPMI-2 and CPMO-2 consist of a valve body with valve seat, cover, a valve plug with a diaphragm unit and a clamp.

The diaphragm unit consists of a stainless steel disc which is divided into sectors and of flexible diaphragms which are placed on each side of the sectors.

The cover and the valve body are clamped together. The valve body and the seat are welded together.

The CPMI-D60 consists of upper and lower valve bodies, an inlet tube, a cover, a valve plug with diaphragm unit and clamps.

The diaphragm unit consists of two flexible diaphragms supported by 12 stainless steel sectors in between them.

The cover and the valve bodies are clamped together.



Fig. 1. CPMI-2 valve.

Fig. 2. CPMI-D60 valve.

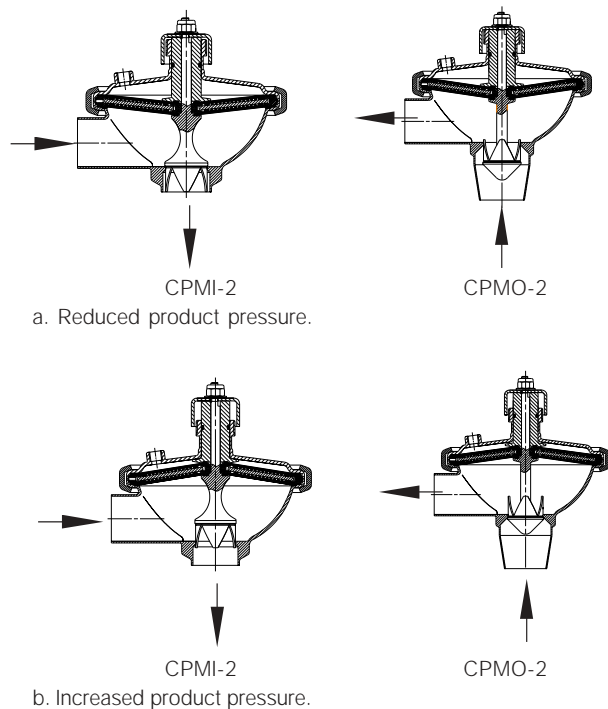
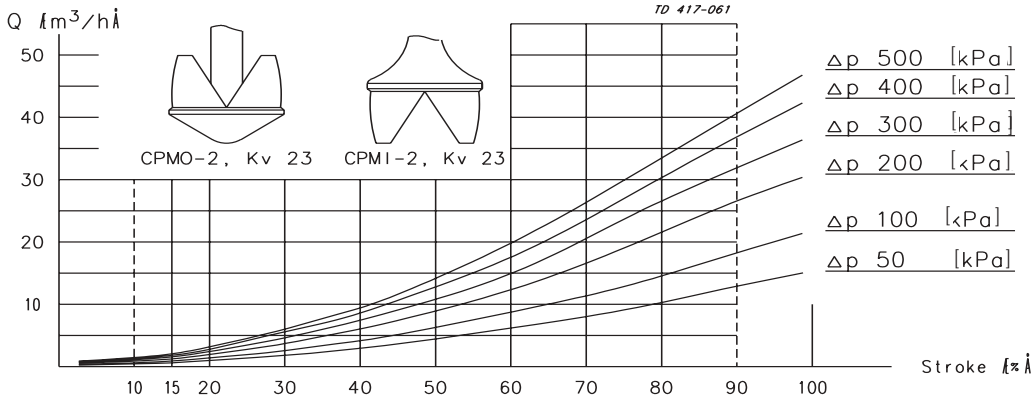

Fig. 3. Principle.

Pressure drop/capacity diagrams

CPM-2, Kv 23



NOTE!
For all diagrams the following applies:
Medium: Water (20°C).
Measurement: In accordance with VDI 2173.

CPMI-2, Kv 7

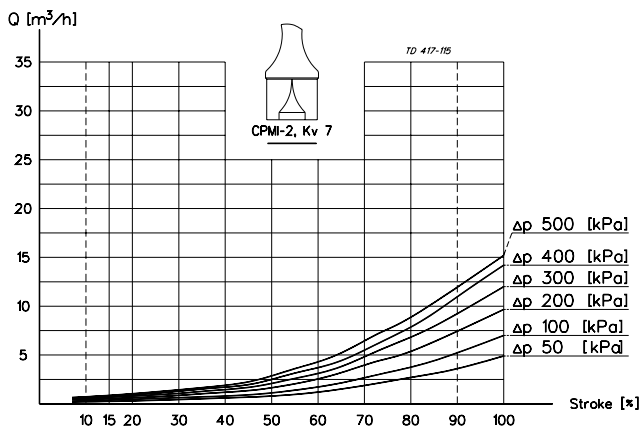

CPMO-2, Kv 9

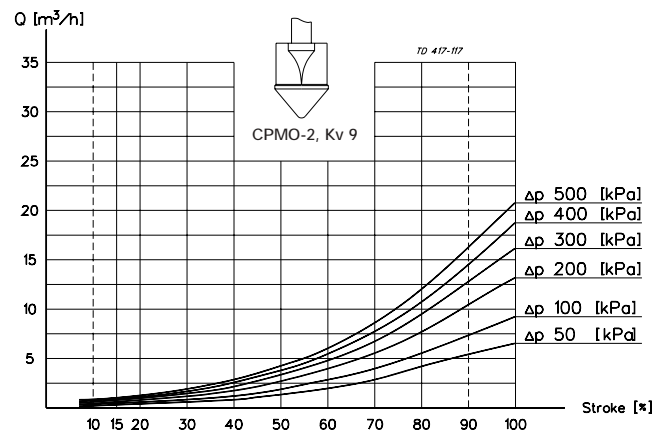

CPM-2, Kv 2/15

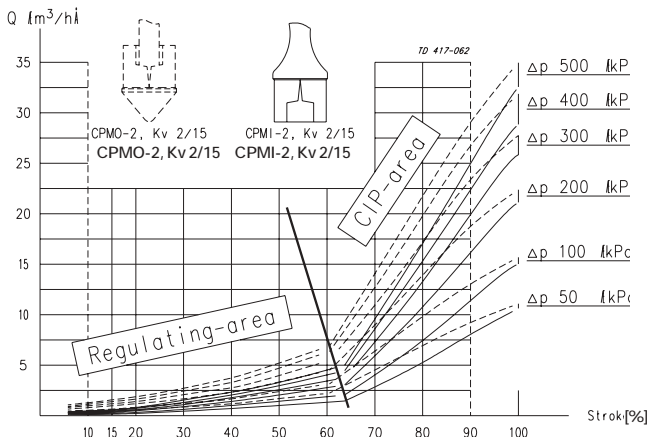

CPM-I-D, Kv 60

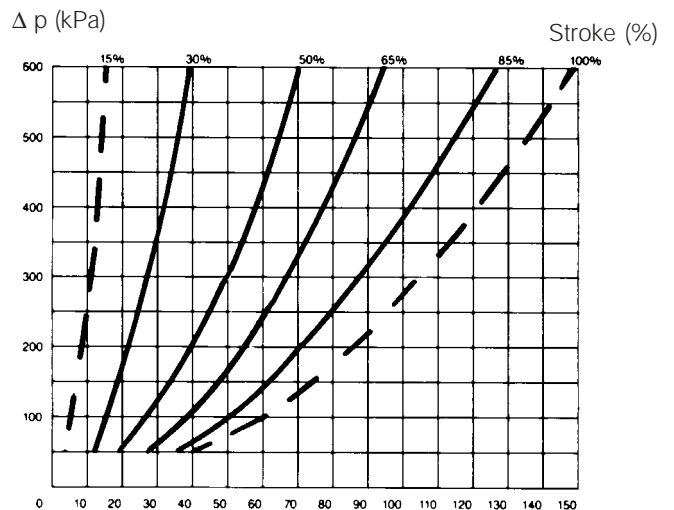

Example 1:

Pressure drop $\Delta p = 200 \text{ kPa}$.
Flow $Q = 8 \text{ m}^3/\text{h}$.
Select: CPM-2, Kv 23 which at working point will be 48% open.

Example 2:

CPMI-2:
Pressure drop $\Delta p = 300 \text{ kPa}$.
Flow $Q = 1 \text{ m}^3/\text{h}$.
Select: CPMI-2, Kv 2/15 which at working point will be approx. 35% open equal to about 50% of the regulating area.

Example of using the diagram:

1. Pressure drop $\Delta p = 300 \text{ kPa}$.
2. Flow = $50 \text{ m}^3/\text{h}$.
The intersection is on the 50% curve.

NOTE! Always try to get as near as possible to the 50% open curve. If the CPM-I-D60 is too big select from the CPMI-2 curves.

3.3

Technical data

Max. product pressure: 1000 kPa (10 bar).
 Min. product pressure: 0 kPa (0 bar).
 Temperature range: -10°C to + 95°C.
 Temperature range with upper diaphragm in PTFE/EPDM: -10°C to +140°C. (Higher on request).

Air pressure (CPMI-2/CPMO-2): 0 to 800 kPa (0 to 8 bar).
 Air pressure (CPM-I-D60): 0 to 600 kPa (0 to 6 bar).
 Flow Kv 23, fully open (Dp = 1 bar): Approx 23 m³/h.
 Flow Kv 7 (Dp = 1 bar): Approx 7 m³/h.
 Flow Kv 9 (Dp = 1 bar): Approx 9 m³/h.
 Flow Kv2/15, low capacity (Dp = 1 bar): Approx 2 m³/h.
 (Alternative size) (regulating area). Approx. 15 m³/h. (CIP area).
 Flow range Kv60, fully open (Dp = 1 bar) (CPM-I-D60) Approx 60 m³/h.

Materials

Product wetted steel parts: Acid-resistant steel 1.4404 (316L).
 Other steel parts: Stainless steel 1.4301 (304).
 Finish: Semi-bright.
 Lower diaphragm: PTFE covered EPDM rubber.
 Upper diaphragm: Nitrile (NBR).

Air Connections

R 1/4" (BSP), internal thread.

Dimensions (mm)

Size	CPMI-2			CPMO-2			CPM-I-D60 76 mm
	Kv 23	Kv 7	Kv 2/15	Kv 23	Kv 9	Kv 2/15	
A1	175.1	175.1	175.1	211	175.1	175.1	413.2
A2	193.4	193.4	193.4	229.3	229.3	193.4	430
C							155
OD (Inch/DIN)	50.8/53	50.8/53	50.8/53	50.8/53	50.8/53	50.8/53	76
ID (Inch/DIN)	47.6/50	47.6/50	47.6/50	47.6/50	47.6/50	47.6/50	72
t (Inch/DIN)	1.6/1.5	1.6/1.5	1.6/1.5	1.6/1.5	1.6/1.5	1.6/1.5	2
E (Inch/DIN)	49/50	49/50	49/50	89/86	49/50	49/50	
F	18.3	18.3	18.3	18.3	18.3	18.3	16.8
G	110	110	110	110	110	110	
G1							53
G2							240
H	203	203	203	203	203	203	200
M/ISO clamp	21	21	21	21	21	21	21
M/ISO male	21	21	21	21	21	21	21
M/DIN male	22	22	22	22	22	22	30
M/SMS male	20	20	20	20	20	20	24
M/BS male	22	22	22	22	22	22	22
Seat diameter	42	31	31	42	31	31	
Weight (kg)	5.5	5.5	5.5	5.5	5.5	5.5	10

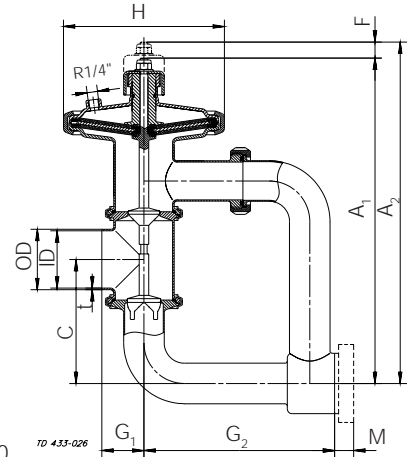
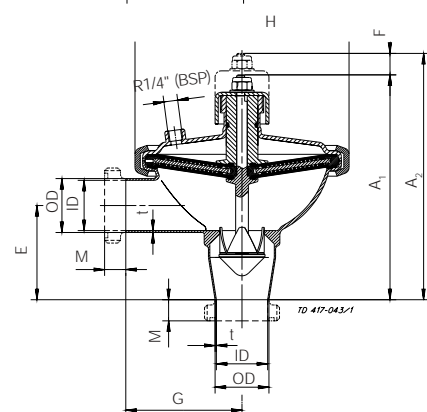
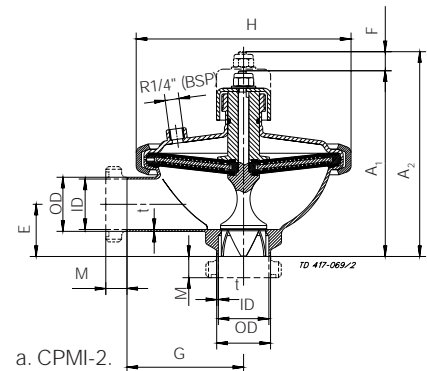

Fig. 4. Dimensions.

Options

- A) Male parts or clamp liners in accordance with required standard.
- B) Air pressure regulating valve kit, 0-8 bar.
- C) Air throttling valve for adjustment of regulating speed for the CPM-2 valve.
- D) Booster for product pressure exceeding the available air pressure. (Product pressure = 1.8 x air pressure).
- E) 3A (Sanitary Standard) labelling on request for CPM-2 Valves.

Material grades CPM-2

- F) Upper diaphragm of PTFE covered EPDM and O-ring of Fluorinated rubber (FPM) covered EPDM rubber, (for temperature 95-140°C).
- G) Both diaphragms of solid PTFE and O-ring of Fluorinated rubber (FPM) (for temperatures above 140°C).

Material grades CPM-I-D60

- H) Upper diaphragm of PTFE covered EPDM rubber.
- I) Valve body seal rings of Nitrile (NBR) or Fluorinated rubber (FPM).
- J) Guide O-ring of Fluorinated rubber (FPM), (for temperatures above 95°C).

Ordering CPM-2

Please state the following when ordering:

- Valve type. (CPMI-2 or CPMO-2).
- Plug size (Kv 23, Kv 7, Kv 9 or Kv 2/15).
- Diaphragm type if not standard.
- Connections if not welding ends.
- Options.

Ordering CPM-I-D60

Please state the following when ordering:

- Valve type CPM-I-D60.
- Diaphragm type if not standard.
- Connections if not welding ends.
- Air pressure regulating valve if required.
- Other options.

Note! For further details, see also instructions IM 70775 and IM70779.

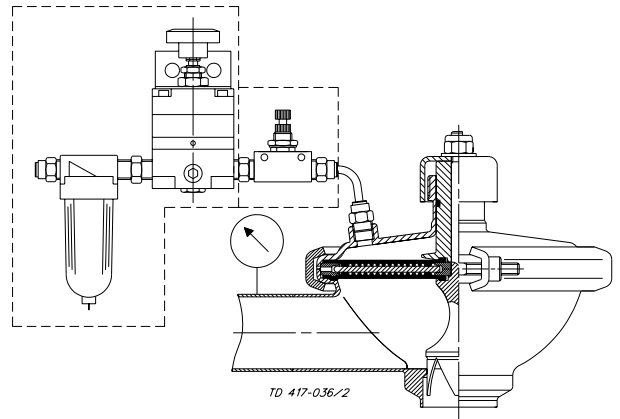

Fig. 5. CPM-2 with pressure regulating valve and pressure gauge.