

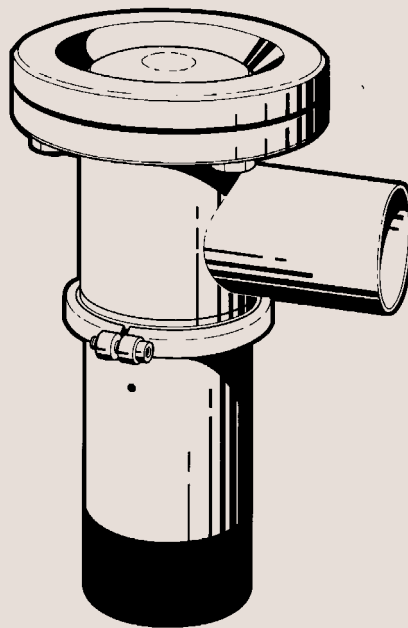

Instruction Manual

LKAB Tank Outlet Valve



Declaration of Conformity

The designating company

Alfa Laval

Company Name

6000 Kolding

Address

+45 79 32 22 00

Phone No.

hereby declare that

TANK OUTLET VALVE

Denomination

LKAB

Type

Year

Was manufactured in conformity with the provisions in the COUNCIL DIRECTIVE of 14 June 1989 on mutual approximation of the laws of the Member States on the safety of machines (89/392/EEC as amended by directives 91/368/EEC and 93/44/EEC) with special reference to Annex 1 of the directive on essential safety and health requirements in relation to the construction and manufacture of machines.

Bjarne Søndergaard

Name

Vice President, R & D

Title

Alfa Laval

Company



Signature

Designation



Table of contents

This manual is divided into main sections. - See below.

Safety

1. Important information	2
2. Warning signs	2
3. Safety precautions	3

Installation

1. Unpacking/Delivery	4
2. General installation	5
3. Welding	6

Operation

1. Operation	7
2. Fault finding	7
3. Recommended cleaning	8

Maintenance

1. General maintenance	9
2. Dismantling	10
3. Assembly	11

Technical data

1. Technical data	12
-------------------------	----

Drawings/Parts list

1. Parts list	14+16
2. Exploded drawing	15
3. Drawing/Parts list	17

Safety

Unsafe practices and other important information are emphasized in this manual.

Warnings are emphasized by means of special signs.

1. Important information

Always read the manual before using the valve!

2

- WARNING!** : Indicates that special procedures **must** be followed to avoid severe personal injury.
- CAUTION!** : Indicates that special procedures **must** be followed to avoid damage to the valve.
- NOTE!** : Indicates important information to simplify practices or to make them clearer.

2. Warning signs



: General warning.



: Caustic agents.

All warnings in the manual are summarized on this page.

Pay special attention to the instructions below so that severe personal injury or damage to the valve are avoided.

3. Safety precautions

Installation:



- : - **Always** observe the technical data (see page 12).
- **Always** release compressed air after use.



- : **Never** stick your fingers through the valve ports if the actuator is supplied with compressed air.

Operation:



- : **Always** observe the technical data (see page 12).



- : **Never** touch the valve or the pipelines when processing hot liquids or when sterilizing.



- : **Always** handle lye and acid with great care.

Maintenance:



- : - **Always** observe the technical data (see page 12).
- **Always** release compressed air after use.
- The actuator spring (11) is **not** caged.
- **Always** press against piston (12) when the actuator spring is released.



- : - The valve must **never** be hot when serviced.
- The valve and the pipelines must **never** be pressurised, and the tank **must** be empty when the valve is serviced.

Installation

4

*The instruction manual is part of the delivery.
Study the instructions carefully.*

*The items refer to the drawings and parts list on
pages 14-17.*

1. Unpacking/Delivery

1

NOTE!

We cannot be held responsible for incorrect un-
packing.

Check the delivery:

1. Complete valve (see 2).
2. Delivery note.
3. Instruction manual.

2

Standard delivery:

1. Complete valve.
2. Welding flange (4), (*).
3. Seal (5), (*).
4. Screws (6), (*).

(*): Fitted on the valve.

3

Clean the valve ports from possible packing
materials.

5

Avoid damaging the air connection and the valve
ports.

4

Inspect the valve for visible transport damage.

Study the instructions carefully and pay special attention to the warnings!

The valve has welding ends as standard but can also be supplied with fittings.

2. General installation

1



- **Always** observe the technical data (see page 12).
- **Always** release compressed air after use.

NOTE!

We cannot be held responsible for incorrect installation.

2

Always install the valve vertically.

3

4

Avoid stressing the valve.

Pay special attention to:

- Vibrations.
- Thermal expansion of the tubes.
- Excessive welding.
- Overloading of the pipelines.

Fittings:

Ensure that the connections are tight (remember seal rings).

5

Air connection: R 1/8" (BSP).

Installation

6

Study the instructions carefully and pay special attention to the warnings!

The valve has welding ends as standard.
The items refer to the drawings and the parts list on pages 14-17.

3. Welding

1

Cutting danger!

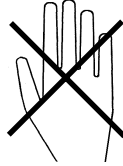

Never stick your fingers through the valve ports if the actuator is supplied with compressed air.

2

Dismantle the valve in accordance with the instructions on page 10.

Pay special attention to the warnings!

3

1. Weld the flange into the tank.
2. Maintain the minimum clearance A_1 so that the valve can be removed.
3. Note the max. stroke S of the valve plug into the tank.

Valve size	A_1 mm	S (mm)
51 mm	325	19
63.5 mm	350	19
76 mm	350	19
101.6 mm	385	28

Bottom of tank

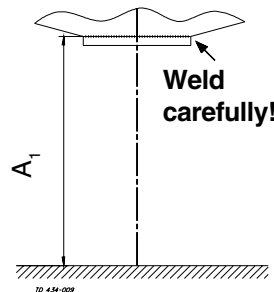

a. Min. clearance A_1 .

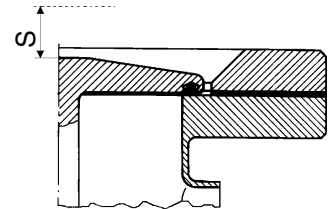

b. Max. stroke S .

4

NOTE!

It is recommended to fit the valve to the pipelines by means of fittings so that the valve can be removed from the tank.

5

Assemble the valve in accordance with the instructions on page 11.

Pre-use check!

1. Supply compressed air to the actuator.
2. Open and close the valve several times to ensure that it operates smoothly.

The valve is adjusted and tested before delivery. Study the instructions carefully and pay special attention to the warnings!

Pay attention to possible faults. The items refer to the drawings and parts list on pages 14-17.

1. Operation

1



Always observe the technical data (see page 12).

NOTE!

We cannot be held responsible for incorrect operation.

2

Burning danger!

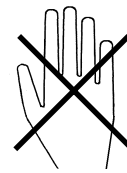

Never touch the valve or the pipelines when processing hot liquids or when sterilizing.

2. Fault finding

NOTE!

Study the maintenance instructions carefully before replacing worn parts. - See page 9!

Problem	Cause/result	Repair
Product leakage at the welding flange	Worn/product affected seal (5)	- Replace the seal - Select a different rubber grade
Product leakage through the drain hole	Worn/product affected lip seal (7)	- Replace the lip seal - Select a different rubber grade
Product leakage through the plug seal	- Worn/product affected O-ring (3) - Pressure/pressure shock from the product	- Replace the O-ring - Select a different rubber grade - Check the pressure data - Supply extra air pressure to spring (11), (weld an air fitting R 1/8" on the drain hole)
Air leakage through the drain hole	Worn seal(s) (14)	Replace the seal(s)

Operation

8

The valve is designed for cleaning in place (CIP).
CIP = Cleaning In Place.

Study the instructions carefully and pay special attention to the warnings!

NaOH = Caustic Soda.

HNO₃ = Nitric acid.

3. Recommended cleaning

1

Caustic danger!



Always use rubber gloves!



Always use protective goggles!



Always handle lye and acid with great care.

3

Examples of cleaning agents:

Use clean water, free from chlorides.

1. 1% by weight NaOH at 70°C.

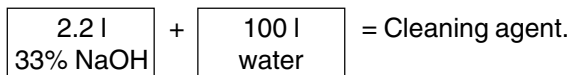
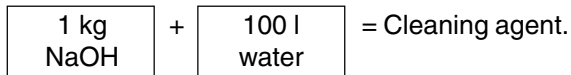

2. 0.5% by weight HNO₃ at 70°C.

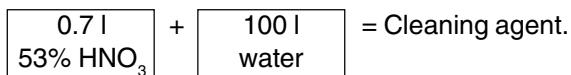

5

Always!

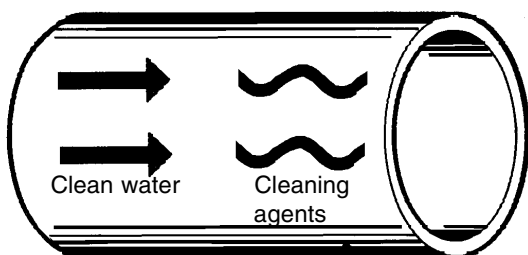

Always rinse well with clean water after the cleaning.

2

Burning danger!

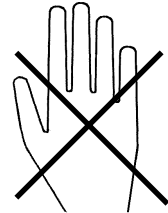

Never touch the valve or the pipelines when sterilizing.

4

1. Avoid excessive concentration of the cleaning agent

⇒ Dose gradually!

2. Adjust the cleaning flow to the process

⇒ Milk sterilization/viscous liquids

⇒ Increase the cleaning flow!

6

NOTE!

The cleaning agents must be stored/discharged in accordance with current rules/directives.

Maintain the valve carefully.
Study the instructions carefully and pay special attention to the warnings!

Always keep spare lip seals and rubber seals in stock.
Check the valve for smooth operation after service.

1. General maintenance

1



- **Always** observe the technical data (see page 12).
- **Always** release compressed air after use.
- The actuator spring (11) is **not** caged.
- **Always** press against piston (12) when the actuator spring is released.

NOTE!

All scrap must be stored/discharged in accordance with current rules/directives.

2

Atmospheric pressure and empty tank required!

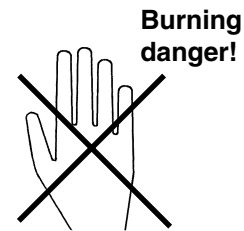

- The valve must **never** be hot when serviced.
- The valve and the pipelines must **never** be pressurised, and the tank **must** be empty when the valve is serviced.

Ordering spare parts

- Contact the Sales Department.
- Order from the Spare Parts List.

Recommended spare parts: Service kits (see Spare Parts List).

	Valve lip seal	Valve rubber seals	Actuator rubber seals
Preventive maintenance	Replace after 12 months	Replace when replacing the lip seal	Replace after 5 years
Maintenance after leakage (leakage normally starts slowly)	Replace at the end of the day	Replace when replacing the lip seal	Replace when necessary
Planned maintenance	<ul style="list-style-type: none"> - Regular inspection for leakage and smooth operation - Keep a record of the valve - Use the statistics for planning of inspections Replace after leakage	Replace when replacing the lip seal	<ul style="list-style-type: none"> - Regular inspection for leakage and smooth operation - Keep a record of the valve - Use the statistics for planning of inspections Replace after air leakage
Lubrication	Before fitting Silicone grease or silicone oil	Before fitting Silicone grease or silicone oil	Before fitting Grease or oil

Maintenance

10

*Study the instructions carefully.
The items refer to the drawings and the parts list on
pages 14-17.*

Handle scrap correctly.

2. Dismantling

1

1. Remove screws (6).
2. Remove the valve from the tank.
3. Remove seal (5) from valve body (1).

3

1. Press against piston (12).
2. Remove connex pin (13).
3. Release the pressure against the piston.

Pay special attention to the warnings!

5

1. Remove valve plug (2) from valve body (1).
2. Remove O-ring (3) from the valve plug.

7

Remove lip seal (7) from valve body (1).

2

1. Remove screws (16) and clamp (15).
2. Remove air cylinder (17).
3. Remove O-ring (8) from the air cylinder.

4

1. Remove piston (12) and spring (11) from valve plug (2).
2. Remove O-ring (8) and seals (14) from the piston (only one seal (14) for valve size 101.6 mm/DN100).

6

1. Remove bottom piece (9) from valve body (1).
2. Remove O-rings (8, 10) from the bottom piece.

Study the instructions carefully.
The items refer to the drawings and the parts list on pages 14-17.

Lubricate the lip seal and the rubber seals before fitting them.

3. Assembly

1

Fit lip seal (7) in valve body (1).

3

1. Fit O-ring (3) on valve plug (2).
2. Release possible air between the O-ring and the O-ring groove.
3. Fit the valve plug through lip seal (7) and bottom piece (9).
4. Push the valve plug until O-ring (3) contacts valve body (1).

5

1. Press against piston (12).
2. Fit connex pin (13) into the piston and valve plug (2).
3. Release the pressure against the piston.

7

1. Fit seal (5) on valve body (1).
2. Fit the valve on the tank.
3. Fit and tighten screws (6).

2

1. Fit O-rings (8, 10) on/in bottom piece (9).
2. Fit the bottom piece in valve body (1).

4

1. Fit O-ring (8) and seals (14) in piston (12), (only one seal (14) for valve size 101.6 mm/ DN100).
2. Fit spring (11) and the piston on valve plug (2).

6

1. Fit O-ring (8) in air cylinder (17).
2. Fit the air cylinder on valve body (1).
3. Fit clamp (15) and screws (16).

8

Pre-use check:

1. Supply compressed air to the actuator.
2. Open and close the valve several times to ensure that it operates smoothly.

Pay special attention to the warnings!

Maintenance

It is important to observe the technical data during installation, operation and maintenance.

Inform the personnel about the technical data.

1. Technical data

12

Data - valve/actuator

Size	51 mm	63.5 mm	76 mm	101.6 mm
Valve capacity kV (m ³ /h)	51	87	115	145
Min. air pressure at 5 bar product pressure above the valve (bar)	2.6	5	5	6
Max. product pressure below valve seat when valve is closed (bar)	2.6	1.1	1.1	0.5
Max. test pressure (bar)	10	10	10	10
Max. temperature (°C)	90	90	90	90

Materials

Product wetted steel parts	AISI 316
Other steel parts	AISI 304
Product wetted seals	Nitrile (NBR), (standard)
Other seals	Nitrile (NBR)
Alternative product wetted seals	EPDM and Viton (FPM)
Finish	Semi bright



Drawing/Parts list

The drawings and the parts list include all items.

The items are identical with the items in the Spare Parts List.
When ordering spare parts, please use the Spare Parts List!

Parts list LKAB

14

Item	Qty.	Denomination
1	1	Valve body
2	1	Valv plug
3Δ	1	O-ring
4	1	Welding flange
5Δ	1	Seal
6	4	Screw
7Δ	1	Lip seal
8◆	3	O-ring
9	1	Bottom piece
10◆	1	O-ring
11	1	Spring
12	1	Piston
13	1	Connex pin
14◆	2	Seal (not valve size 101.6 mm/DN100)
	1	Seal (only valve size 101.6 mm/DN100)
15	2	Clamp half
16	2	Screw
17	1	Air cylinder
18	1	Plate
19	1	Cap
20	1	Rubber plug
21	2	Cap nut
22	1	Screw
23	2	Screw (only valve size 101.6/DN100)
24	2	Nut (only valve size 101.6/DN100)
25	2	Washer (only valve size 101.6/DN100)
26	2	Clamp half (only valve size 101.6/DN100)

Δ : Service kit - NBR

◆ : Service kit - actuator

This page shows an exploded drawing of LKAB.

The drawing includes all items of the valve.
They are identical with the items in the Spare Parts List

Exploded drawing

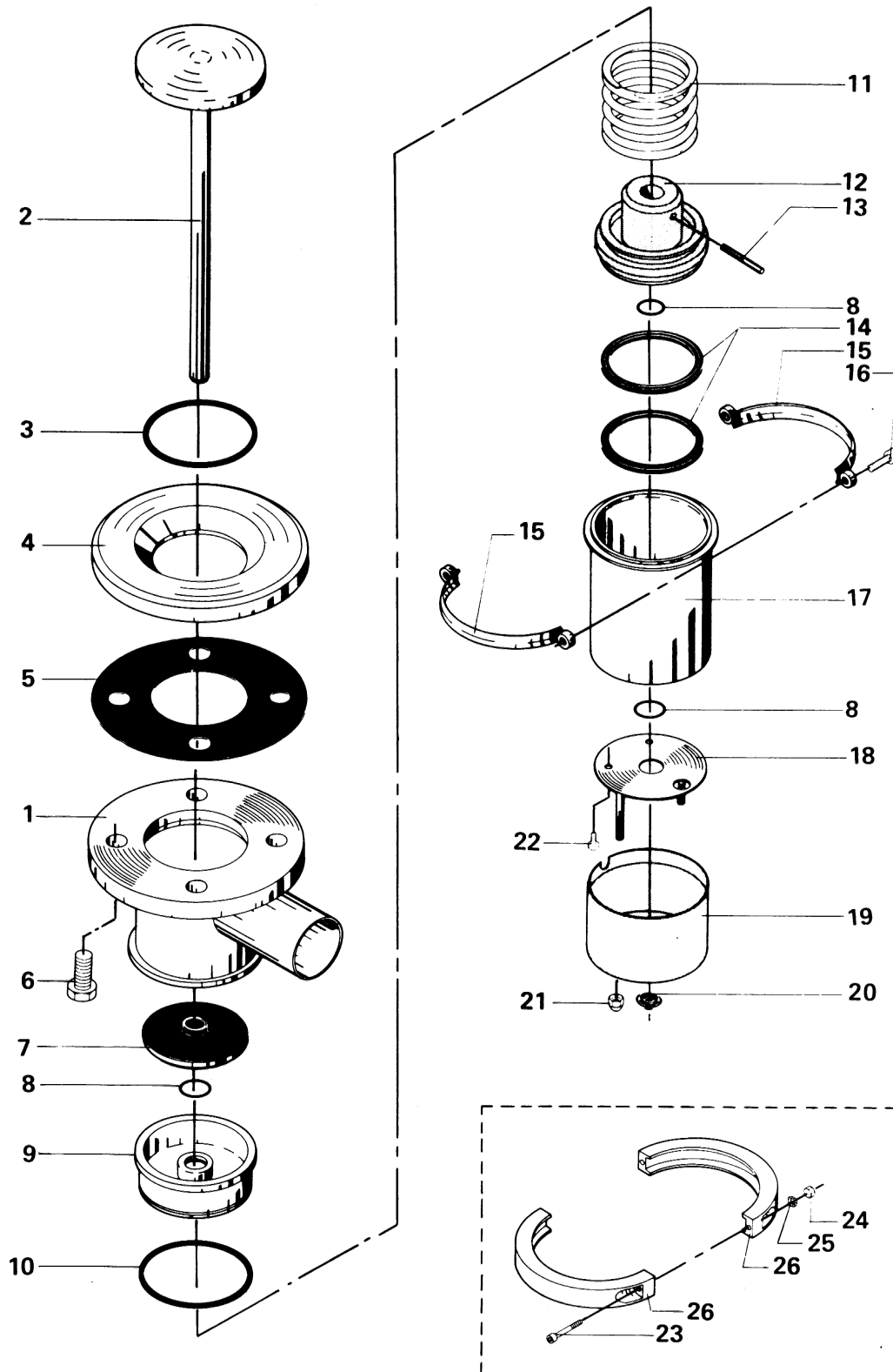

Drawing/Parts list

The drawings and the parts list include all items.

The items are identical with the items in the Spare Parts List.
When ordering spare parts, please use the Spare Parts List!

Parts list LKAB

16

Item	Qty.	Denomination
1	1	Valve body
2	1	Valv plug
3Δ	1	O-ring
4	1	Welding flange
5Δ	1	Seal
6	4	Screw
7Δ	1	Lip seal
8◆	3	O-ring
9	1	Bottom piece
10◆	1	O-ring
11	1	Spring
12	1	Piston
13	1	Connex pin
14◆	2	Seal (not valve size 101.6 mm/DN100)
	1	Seal (only valve size 101.6 mm/DN100)
15	2	Clamp half
16	2	Screw
17	1	Air cylinder
18	1	Plate
19	1	Cap
20	1	Rubber plug
21	2	Cap nut
22	1	Screw
23	2	Screw (only valve size 101.6/DN100)
24	2	Nut (only valve size 101.6/DN100)
25	2	Washer (only valve size 101.6/DN100)
26	2	Clamp half (only valve size 101.6/DN100)

Δ : Service kit - NBR

◆ : Service kit - actuator

The drawings below show LKAB.

The items refer to the parts list on the opposite part of the page.

Drawing

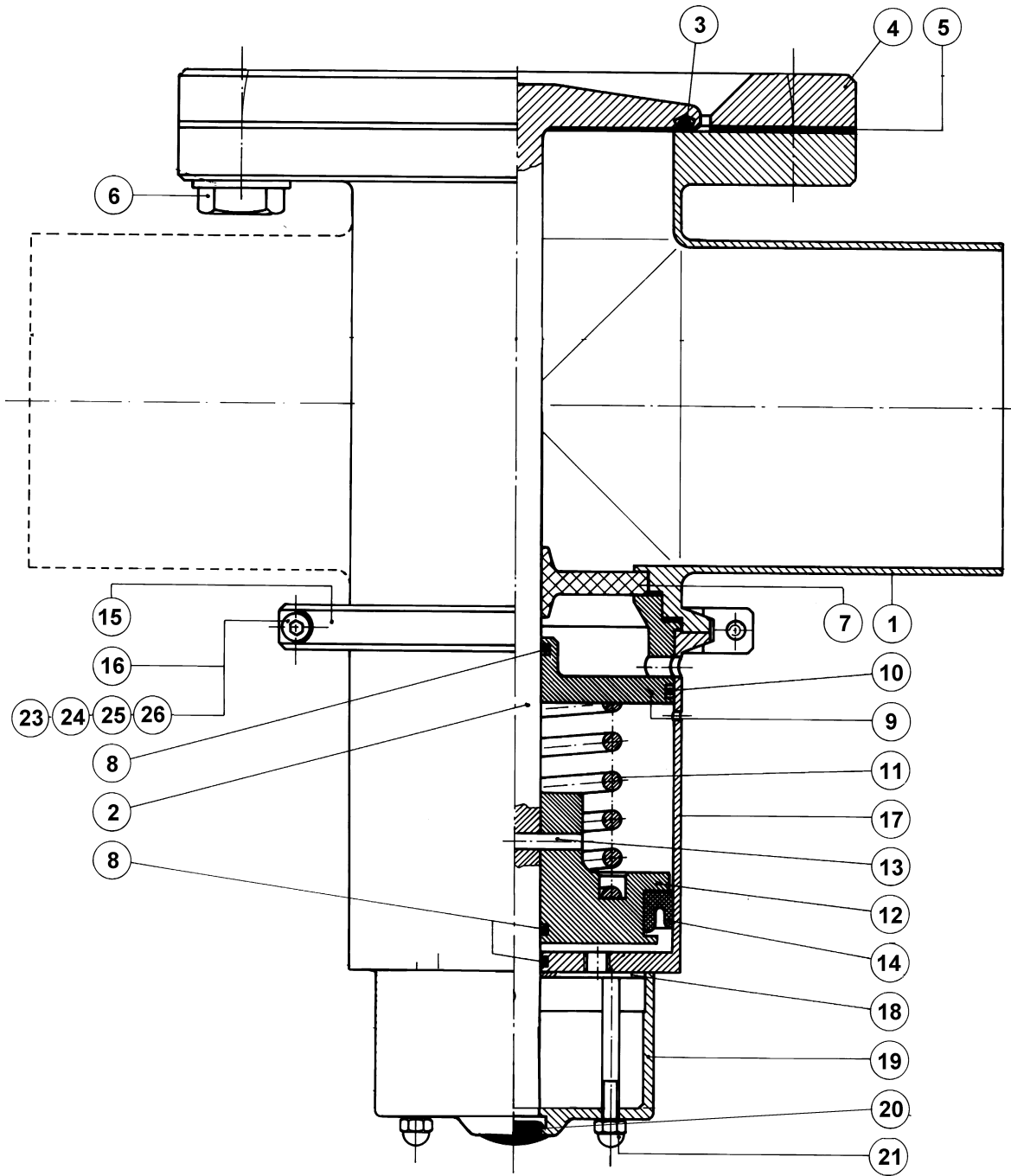

How to contact Alfa Laval

Contact details for all countries are continually updated on our website. Please visit www.alfalaval.com to access the information direct.