



# When you need a High Quality Opening

## Access Tank Cover - Oval Cover Type LKD

### Application

The oval Access Tank Cover LKD manhole covers are used on tanks or containers where a closeable means of access to the interior of the vessel is required.

The particular cover has been designed taking into account today's demands for manhole covers which are suitable for CIP cleaning processes and where access to the tank is only necessary for occasional inspection

### Working principle

Open the cover by loosening the handle. For inspection purposes the cover can then be turned into the tank. If it is necessary to physically enter the tank, the cover can be removed at the double hinge or swung out of the tank, depending on the model. The seal is hygienically positioned and is not affected by positive or negative pressure in the tank.



Upper: LKD 440 x 320, Middle: LKD 535 x 435,  
Lower: LKD 546 x 447

### Materials

Type	LKD 440 x 320	LKD 535 x 435	LKD 546 x 447
Steel parts	1.4301 (304) or 1.4404 (316L) Cover and frame are supplied with inspection certificate 3.1 according to EN10204	1.4301 (304) or 1.4404 (316L) Cover and frame are supplied with inspection certificate 3.1 according to EN10204	1.4301 (304) or 1.4404 (316L) Cover and frame are supplied with inspection certificate 3.1 according to EN10204.
Plastic parts	Nylon	Nylon	Nylon
Seals (FDA)	EPDM, NBR, FPM, Q (silicone)	EPDM, NBR, FPM, Q (silicone)	EPDM, NBR, FPM, Q (silicone)
Standard cover finish	Acid Pickled Internal: Less Ra 0.8 External: Less Ra 0.8	Acid Pickled Internal: Less Ra 0.8 External: Less Ra 0.8	Acid Pickled Internal: Less Ra 0.8 External: Less Ra 0.8
Standard frame finish	Brushed Internal: Less Ra 0.8 External: Less Ra 0.8	Brushed Internal: Less Ra 0.8 External: Less Ra 0.8	Brushed Internal: Less Ra 0.8 External: Less Ra 0.8
Authorized to carry the 3A symbol	Yes	Yes	No
3A finish	Electropolished Internal Less Ra 0.8 (incl. weldings) External Less Ra 0.8	Electropolished Internal Less Ra 0.8 (incl. weldings) External Less Ra 0.8	NA

## Technical data

Type	LKD 440 x 320	LKD 535 x 435	LKD 546 x 447
Max. static pressure	150 kPa (1.5 bar) / 22 psi	250 kPa (2.5 bar) / 36 psi	200 kPa (2 bar) / 29 psi
Max. positive working pressure	0 kPa (0 bar) / 0 psi	0 kPa (0 bar) / 0 psi	0 kPa (0 bar) / 0 psi
Max. negative working pressure	50 kPa (0.5 bar) / 7 psi	50 kPa (0.5 bar) / 7 psi	50 kPa (0.5 bar) / 7 psi
Test pressure	225 kPa (2.25 bar) / 33 psi	375 kPa (3.75 bar) / 54 psi	300 kPa (3 bar) / 44 psi
Temperature range	-20°C to +90°C / -4°F to +194°F (NBR)	-20°C to +90°C / -4°F to +194°F (NBR)	-20°C to +100°C / -4°F to +212°F

### Installation

In order to obtain a perfect seal and a good function of our manhole covers, it is essential that the welding of the casing is carried out carefully and correctly. If the cover is fitted on a vertical tank wall, the hinge of the casing must always be placed on the left hand side. For thin-gauged containers, i.e. sheet thickness less than 2.5 mm, welding is easier, if the hole is marked in such a way that a 10 mm edge can be burred up as sharply as possible.

When the hole is cut and the edge burred up, if applicable, the casing is inserted, and tack-welding is now carried on at points placed opposite each other all the way round, in the sequence shown in fig. 1.

The casing may now be fully welded on both sides. A control should be made by removing the rubber seal, and cover and casing should be assembled loosely to ensure that they fully contact each other over the whole surface.

Any stresses are removed by hammering the sheet around the casing.

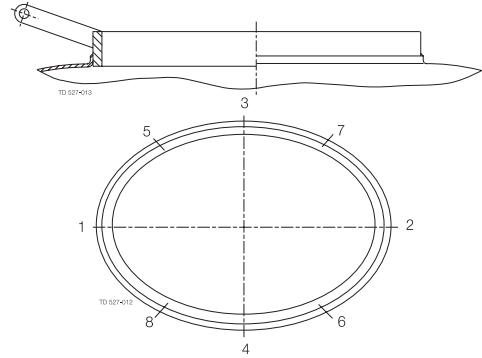

1. Installation of LKD.

### Ordering

Please state the following when ordering:

- Cover size.
- Steel part material: 1.4301 (304) or 1.4404 (316L).
- Seal ring material type: EPDM, NBR, FPM, Q (silicone).
- Frame height

## Dimensions (mm / inch)

Type	LKD 440 x 320	LKD 535 x 435	LKD 546 x 447
A	440 / 17.99	535 / 13.90	461 / 18.15
B	320 / 13.15	435 / 17.13	362 / 14.25
C		663 / 26.10	546 / 21.50
D			447 / 17.60
E	160 / 6.30	257 / 10.12	196 / 7.72
F	60 / 2.36	(100 / 3.94) (60 / 2.36)	76 / 2.99
t	8 / 0.31	12 / 0.47	4 / 0.16
Cover thickness	2 / 0.08	3 / 0.12	3 / 0.12
Weight (kg / lbs)	7.5 / 16.5	(22.5 / 49.6) (18.5 / 40.8)	12 / 26.5

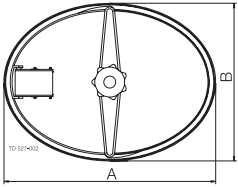

LKD 440 x 320

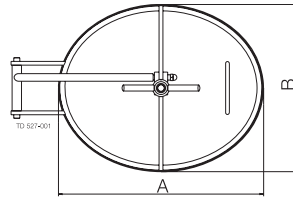
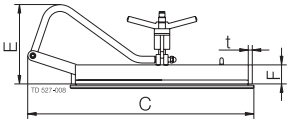

LKD 535 x 435

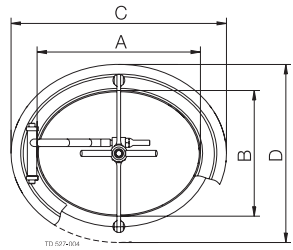
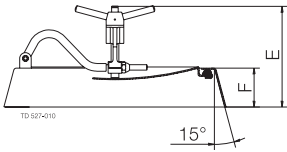

LKD 546 x 447 angle shaped frame

ESE00316EN 0901

The information contained herein is correct at the time of issue,  
but may be subject to change without prior notice.

---

**How to contact Alfa Laval**

Contact details for all countries  
are continually updated on our website.  
Please visit [www.alfalaval.com](http://www.alfalaval.com) to  
access the information direct.