

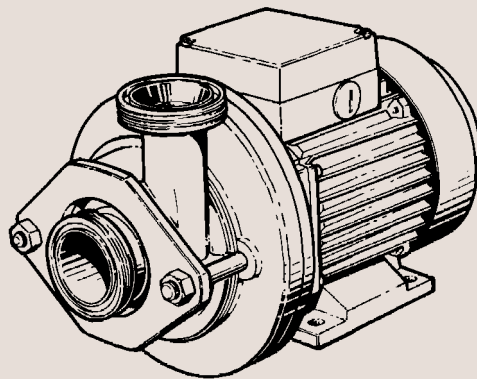

Instruction Manual

FM-OS Centrifugal Pump



Declaration of Conformity

The designating company

Alfa Laval

Company Name

6000 Kolding

Address

+45 79 32 22 00

Phone No.

hereby declare that

Centrifugal Pump

Denomination

FM-OS

Type

Year

is in conformity with the following directives with amendments:

- Low Voltage Directive 73/23/EEC
- EMC Directive 89/336/EEC
- Machinery Directive 89/392/EEC

Bjarne Søndergaard

Name

Vice President, R & D

Title

Alfa Laval

Company

B. Søndergaard

Signature

Designation



Table of contents

This manual is divided into main sections. - See below.

Safety

1. Important information	2
2. Warning signs	2
3. Safety precautions	3

Installation

1. Unpacking/Delivery	4
2. Installation	5
3. Pre-use check	6

Operation

1. Operation/Control	7
2. Fault finding	8
3. Recommended cleaning	9

Maintenance

1. General maintenance	10
2. Dismantling - Single shaft seal	12
3. Dismantling - Flushed shaft seal	13
4. Assembly - Single shaft seal	14
5. Assembly - Flushed shaft seal	15

Technical data

1. Technical data	16
-------------------------	----

Drawings/Parts list

1. Part list	18+20+22
2. Exploded drawing	19+21
3. Drawings	23

Safety

Unsafe practices and other important information are emphasized in this manual.

Warnings are emphasized by means of special signs.

1. Important information

Always read the manual before using the pump!

2

- WARNING!** : Indicates that special procedures **must** be followed to avoid severe personal injury.
- CAUTION!** : Indicates that special procedures **must** be followed to avoid damage to the pump.
- NOTE!** : Indicates important information to simplify practices or to make them clearer.

2. Warning signs



: General warning.



: Dangerous electrical voltage.



: Caustic agents.

All warnings in the manual are summarized on this page.

Pay special attention to the instructions below so that severe personal injury or damage to the pump are avoided.

3. Safety precautions

Installation:



- : **Always** observe the technical data (see page 16).



- : The pump **must** be electrically connected by authorized personnel (see the motor instructions).



- : - **Always** remove the impeller before checking the direction of rotation.
- **Never** start the pump if the impeller is fitted and the pump casing removed.

Operation:



- : **Always** observe the technical data (see page 16).



- : **Never** touch the pump or the pipelines when pumping hot liquids or when sterilizing.



- : **Never** run the pump with both the suction side and the pressure side blocked.



- : **Always** handle lye and acid with great care.

Maintenance:



- : **Always** observe the technical data (see page 16).



- : **Always** disconnect the power supply when the pump is serviced.



- : - The pump must **never** be hot when serviced.
- The pump and the pipelines must **never** be pressurised when the pump is serviced.

Installation

The instruction manual is part of the delivery. Study the instructions carefully.

The standard delivery does not include the test certificate. This can be supplied on request.

1. Unpacking/Delivery

1

NOTE!

We cannot be held responsible for incorrect unpacking.

Check the delivery:

1. Complete pump.
2. Delivery note.
3. Instruction manual.
4. Motor instructions.
5. Test certificate, IF ORDERED!

2

Clean the inlet and the outlet from possible packing materials.

3

4

Inspect the pump for visible transport damage.

Avoid damaging the inlet and the outlet.

5

6

Avoid damaging the connections for flushing liquid, if supplied.

Always remove the shroud, if fitted, before lifting the pump.

Study the instructions carefully and pay special attention to the warnings!

Always check the pump before operation.
- See pre-use check on page 6.

2. Installation

1



Always observe the technical data (see page 16).



The pump **must** be electrically connected by authorized personnel (see the motor instructions).

NOTE!

We cannot be held responsible for incorrect installation.

2

Ensure that there is sufficient clearance around the pump.

3

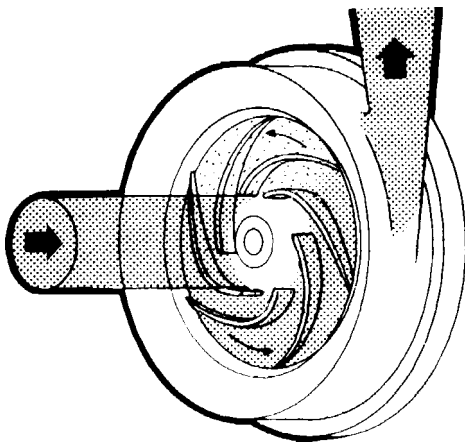

Ensure that the flow direction is correct.

4

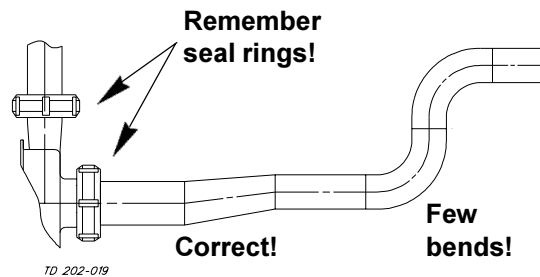

1. Ensure that the pipelines are routed correctly.
2. Ensure that the connections are tight.

5

Risk of damage!

Avoid stressing the pump.

Pay special attention to:

- Vibrations.
- Thermal expansion of the tubes.
- Excessive welding.
- Overloading of the pipelines.

Installation

Study the instructions carefully and pay special attention to the warnings!

Check the direction of rotation of the pump shaft before operation.
- See the indication label on the pump.

3. Pre-use check

1



- **Always** remove the impeller before checking the direction of rotation.
- **Never** start the pump if the impeller is fitted and the pump casing removed.

2

Dismantle the pump in accordance with instructions 1-4 and 7 on page 12 (instruction 1 on page 13 for flushed shaft seal).

3

See the indication label!

1. Start and stop the motor momentarily.
2. Ensure that the direction of rotation of the pump shaft is **anticlockwise** as viewed from the inlet side.

4

Assemble the pump in accordance with instructions 2, 3 and 5-8 on page 14 (instructions 6-8 on page 15 for flushed shaft seal).

Study the instructions carefully and pay special attention to the warnings!

The pump is fitted with a warning label indicating correct throttling.

1. Operation/Control

1

 **Always** observe the technical data (see page 16).

NOTE!

We cannot be held responsible for incorrect operation/control.

2

Burning danger!

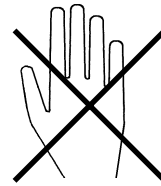

 **Never** touch the pump or the pipelines when pumping hot liquids or when sterilizing.

3

Explosion danger!

⇒ See the warning label!

4



Never run the pump with both the suction side and the pressure side blocked.

CAUTION!

- The shaft seal must not run dry.
- Never throttle the inlet side.

5

Free outlet ←  **Correct!**

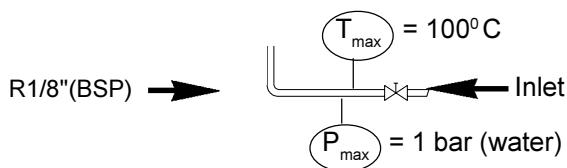

Flushed shaft seal:

1. Connect the inlet of the flushing liquid correctly.
2. Regulate the water and steam supply correctly.
3. Observe the steam data.

6

Control:

- Reduce the capacity and the power consumption by means of:
- Throttling the pressure side of the pump.
 - Reducing the impeller diameter.
 - Speed control of the motor.

Pay attention to possible faults.

Study the instructions carefully.

2. Fault finding

NOTE!

Study the maintenance instructions carefully before replacing worn parts. - See page 10!

8

Problem	Cause/result	Repair
Overloaded motor	<ul style="list-style-type: none">- Pumping of viscous liquids- Pumping of liquids with high density- Low outlet pressure (counter pressure)	<ul style="list-style-type: none">- Smaller impeller- Higher counter pressure (throttling)
Cavitation: <ul style="list-style-type: none">- Damage- Pressure reduction (sometimes to zero)- Increasing of the noise level	<ul style="list-style-type: none">- Low inlet pressure- High liquid temperature	<ul style="list-style-type: none">- Increase of the inlet pressure- Reduce the liquid temperature- Reduce the pressure drop before the pump
Leaking shaft seal	<ul style="list-style-type: none">- Dry run (See page 7)- Incorrect rubber grade- Abrasive particles in the liquid	Replace: All wearing parts (See page 10) <ul style="list-style-type: none">- Select a different rubber grade- Select stationary and rotating seal ring in Silicon Carbide/ Silicon Carbide
Leaking seals	<ul style="list-style-type: none">- Incorrect rubber grade	Select a different rubber grade

The pump is designed for cleaning in place (CIP).
CIP = Cleaning In Place.

Study the instructions carefully and pay special attention to the warnings!
NaOH = Caustic Soda.
HNO₃ = Nitric acid.

3. Recommended cleaning

1

Caustic danger!



Always use rubber gloves!



Always use protective goggles!



Always handle lye and acid with great care.

3

Examples of cleaning agents:

Use clean water, free from chlorides.

- 1% by weight NaOH at 70° C.

1 kg NaOH	+	100 l water	= Cleaning agent.
--------------	---	----------------	-------------------

2.2 l 33%NaOH	+	100 l water	= Cleaning agent.
------------------	---	----------------	-------------------

- 0.5% by weight HNO₃ at 70° C.

0.7 l 53% HNO ₃	+	100 l water	= Cleaning agent.
-------------------------------	---	----------------	-------------------

5

Always!

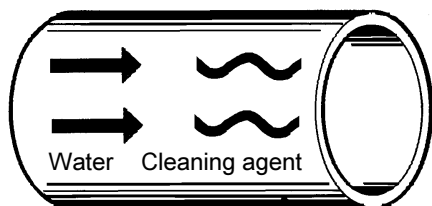

Always rinse well with clean water after the cleaning.

2

Burning danger!

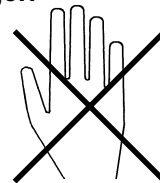

Never touch the pump or the pipelines when sterilizing.

4

1. Avoid excessive concentration of the cleaning agent

⇒ **Dose gradually!**

2. Adjust the cleaning flow to the process

Milk sterilization/viscous liquids

⇒ **Increase the cleaning flow!**

6

NOTE!

The cleaning agents must be stored/discharged in accordance with current rules/directives.

Maintenance

10

Maintain the pump carefully.
Study the instructions carefully and pay special attention to the warnings!

Always keep spare shaft seals and rubber seals in stock.
See separate motor instructions.

1. General maintenance

1

 **Always** observe the technical data (see page 16).

 **Always** disconnect the power supply when the pump is serviced.

NOTE!

All scrap must be stored/discharged in accordance with current rules/directives.

2

Burning danger!

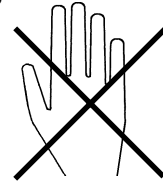

 The pump must **never** be hot when serviced.

3

Atmospheric pressure required!

 The pump and the pipelines must **never** be pressurised when the pump is serviced.

4

CAUTION!

Fit the electrical connections correctly if they have been removed from the motor during service (see pre-use check on page 6).

Pay special attention to the warnings!

Ordering spare parts

- Contact the Sales Department.
- Order from the Spare Parts List.

Recommended spare parts: Service kits (see Spare Parts List).

Maintain the pump carefully.
 Study the instructions carefully.
 Always keep spare shaft seals and rubber seals in stock.

See separate motor instructions.
 Check the pump for smooth operation after service.

1. General maintenance

	Shaft seal	Rubber seals	Motor bearings
Preventive maintenance	Replace after 12 months: (one-shift) Complete shaft seal	Replace when replacing the shaft seal	
Maintenance after leakage (leakage normally starts slowly)	Replace at the end of the day: Complete shaft seal	Replace when replacing the shaft seal	
Planned maintenance	<ul style="list-style-type: none"> - Regular inspection for leakage and smooth operation - Keep a record of the pump - Use the statistics for planning of inspections Replace after leakage: Complete shaft seal	Replace when replacing the shaft seal	Yearly inspection is recommended - Replace complete bearing if worn
Lubrication	Before fitting Lubricate the O-rings with silicone grease or silicone oil (not the sealing surfaces)	Before fitting Silicone grease or silicone oil	None The bearings are permanently lubricated

Maintenance

12

*Study the instructions carefully.
The items refer to the drawings and the parts list on
pages 18-23.*

Handle scrap correctly.

2. Dismantling of pump/Removing the single shaft seal

1

Remove nuts (8) and yoke (5).

3

Turn impeller (6) anticlockwise and remove it from pump shaft (26), (use a plastic hammer, if necessary).

5

Turn nut (24) **clockwise** and remove it from stationary seal ring (23).

7

1. Remove rotating seal ring (27) and O-ring (29) from pump shaft (26).
2. Remove spring (22) from the rotating seal ring.

2

Remove pump casing (7) and O-ring (10) from back plate (9), (use a plastic hammer, if necessary).

4

1. Remove back plate (9).
2. The shaft seal is now accessible.

6

Remove stationary seal ring (23) and seal (25) from back plate (9).

8

1. Remove screws (2) and washers (3).
2. Remove adaptor (4).
3. Remove pin (28) and thrower (21).
4. Remove pump shaft (26) from the motor shaft.

Study the instructions carefully.
The items refer to the drawings and the parts list on pages 18-23.

Handle scrap correctly.

3. Dismantling of pump/Removing the flushed shaft seal

1

1. Remove nuts (8) and yoke (5).
2. Remove pump casing (7) and O-ring (10) from back plate (9), (use a plastic hammer, if necessary).
3. Turn impeller (6) anticlockwise and remove it from pump shaft (42), (use a plastic hammer, if necessary).

3

1. Remove flushing tubes (45).
2. Turn seal housing (35) **clockwise** and remove it together with fastening ring (43).
3. Remove O-ring (41) from the fastening ring.

5

1. Remove screws (39).
2. Remove fastening ring (43) and O-ring (40) from seal housing (35).
3. The shaft seal is now accessible.

7

Remove stationary seal ring (33) and O-ring (32) from seal housing (35).

2

Remove back plate (9) together with the complete shaft seal and intermediate flange (44).

4

Remove stationary seal ring (23) and seal (25) from back plate (9).

6

Remove rotating seal rings (36), O-rings (29), washers (30), spring (37) and spacer (31) from seal housing (35).

8

1. Remove screws (2) and washers (3).
2. Remove adaptor (4).
3. Remove pin (34).
4. Remove pump shaft (42) from the motor shaft.

Maintenance

14

Study the instructions carefully.
The items refer to the drawings and the parts list on pages 18-23.

Lubricate the rubber seals before fitting them.

4. Assembly of pump/Fitting the single shaft seal

1

1. Fit thrower (21) on pump shaft (26).
2. Fit the pump shaft on the motor shaft and lock it with pin (28).
3. Fit adaptor (4), washers (3) and screws (2).
4. Lubricate the external surface of the pump shaft.

2

1. Lubricate O-ring (29).
2. Fit the O-ring on pump shaft (26).

NOTE!

Ensure correct position of the joint if using Teflon O-ring.

3

1. Lubricate the inner surface of rotating seal ring (27).
2. Fit spring (22) on the rotating seal ring.
3. Push the rotating seal ring over O-ring (29) as far as possible against the shoulder.

4

1. Fit seal ring (25) and stationary seal ring (23) in back plate (9).
2. Fit nut (24), turn it **anticlockwise** and tighten.

5

Fit back plate (9) together with the stationary shaft seal parts on adaptor (4).

6

1. Fit impeller (6) with the rounded part of the hub outwards and turn it clockwise.
2. Check the clearance between back plate (9) and the impeller (0.8-1 mm).

7

Fit and tighten correctly!

1. Lubricate O-ring (10) and fit it on back plate (9).
2. Fit pump casing (7).

8

Fit yoke (5) and nuts (8).

Study the instructions carefully.
The items refer to the drawings and the parts list on pages 18-23.

Lubricate the rubber seals before fitting them.
Assembly mandrel: For assembly of flushed shaft seal.

5. Assembly of pump/Fitting the flushed shaft seal

1

1. Fit pump shaft (42) on the motor shaft and lock it with pin (34).
2. Fit adaptor (4), washers (3) and screws (2).
3. Lubricate the external surface of the pump shaft.

2

1. Fit seal (25) and stationary seal ring (23) on back plate (9).
2. Fit O-ring (41) in fastening ring (43).
3. Fit the fastening ring to the back plate, turn it **anticlockwise** and tighten.

3

Assemble the shaft seal in correct order!

1. Push assembly mandrel (46) through the hole in the assembled back plate.
2. Fit rotating seal rings (36), O-rings (29), washers (30), spring (37) and spacer (31).

NOTE!

Ensure correct position of the joint if using Teflon O-rings.

4

1. Fit O-rings (32, 40) and stationary seal ring (33) in seal housing (35).
2. Tighten the seal housing to fastening ring (43) by means of screws (39).
3. Fit intermediate flange (44) on back plate (9).
4. Fit and tighten flushing tubes (45).

5

1. Push mandrel (46) together with the shaft seal parts onto pump shaft (42).
2. Push back plate (9) together with the shaft seal into its correct position.

6

1. Fit impeller (6) with the rounded parts of the hub outwards and turn it clockwise.
2. Check the clearance between back plate (9) and the impeller (0.8-1 mm).

7

Fit and tighten correctly!

1. Lubricate O-ring (10) and fit it on back plate (9).
2. Fit pump casing (7).

8

Fit yoke (5) and nuts (8).

Technical data

It is important to observe the technical data during installation, operation and maintenance.

Inform the personnel about the technical data.

16

1. Technical data

Data

Max. inlet pressure	400 kPa (4 bar)
Temperature range	-10°C to +140°C (EPDM)
Impeller diameter, FM-OS/95	95 mm
FM-OS/115	115 mm

Materials

Product wetted steel parts	AISI 316L
Other steel parts	AISI 304
Product wetted seals	Nitrile (NBR), (standard)
Alternative seals	EPDM, Viton (FPM) and Teflon (PTFE)
Finish	Semi bright

Shaft seal

Seal types	Mechanical single or flushed seal
Max. water pressure (flushed seal)	Normally atmospheric (max. 1bar)
Water consumption (flushed seal)	0.25 - 0.5 l/min.
Material, stationary seal ring	AISI 329 with sealing surface of Silicon Carbide
Material, rotating seal ring	Carbon (standard) or Silicon Carbide
Material, O-rings	Nitrile (NBR), (standard)
Alternative material, O-rings	EPDM, Viton (FPM) and Teflon (PTFE)

Motor

Standard foot-flanged motor acc. to IEC metric standard
2 pol = 3000/3600 rpm. at 50/60 Hz
IP55 (with drain holes with labyrinth plug), insulation class F

Voltage and frequency

(3~, 50 Hz, 220-240V Δ /380-420VY)
(3~, 60 Hz, 250-280V Δ /440-480VY)

Motor size (kW), 50 Hz	1.1
Motor size (kW), 60 Hz	1.3



Drawing/Parts list

The drawing and the parts list include all items of the pump.

The items are identical with the items in the Spare Parts List.
When ordering spare parts, please use the Spare Parts List!

Parts List FM-OS, Single shaft seal

18

Pos.	Qty.	Denomination
1	1	Motor
2	4	Screw
3	4	Spring washer
4	1	Adaptor
5	1	Yoke
6	1	Impeller
7	1	Pump casing
8	2	Nut
9	1	Black plate
10 Δ	1	O-ring
11	2	Stud bolt
21 \circ	1	Thrower
22 $\Delta \circ$	1	Spring
23	1	Stationary seal ring
24 \circ	1	Nut
25	1	Seal
26 \circ	1	Pump shaft
27 \circ	1	Rotating seal ring
28 \circ	1	Tubular spring pin
29 \circ	1	O-ring
29a \square	1	O-ring, front
29b \square	1	O-ring, back
30 \square	3	Washer
31 \square	1	Spacer
32 \square	1	O-ring
33 \square	1	Stationary seal ring
34 \square	1	Tubular spring pin
35 \square	1	Seal housing
36 \square	2	Rotating seal ring
37 \square	1	Spring
39 \square	4	Srew
39a \square	4	Washer
40 \square	1	O-ring
41 \square	1	O-ring
42 \square	1	Pump shaft
43 \square	1	Fastening ring
44 \square	1	Intermediate flange
45 \square	2	Flushing tube
46 \square	1	Assembly mandrel (not shown)

Δ : Service kit - EPDM, NBR, FPM, PTFE
(See Spare Parts List)

\circ : Single shaft seal only

\square : Flushed shaft seal only

This page shows an exploded drawing of FM-O with single shaft seal.

The drawing includes all items of the pump. They are identical with the items in the Spare Parts List.

Exploded drawing

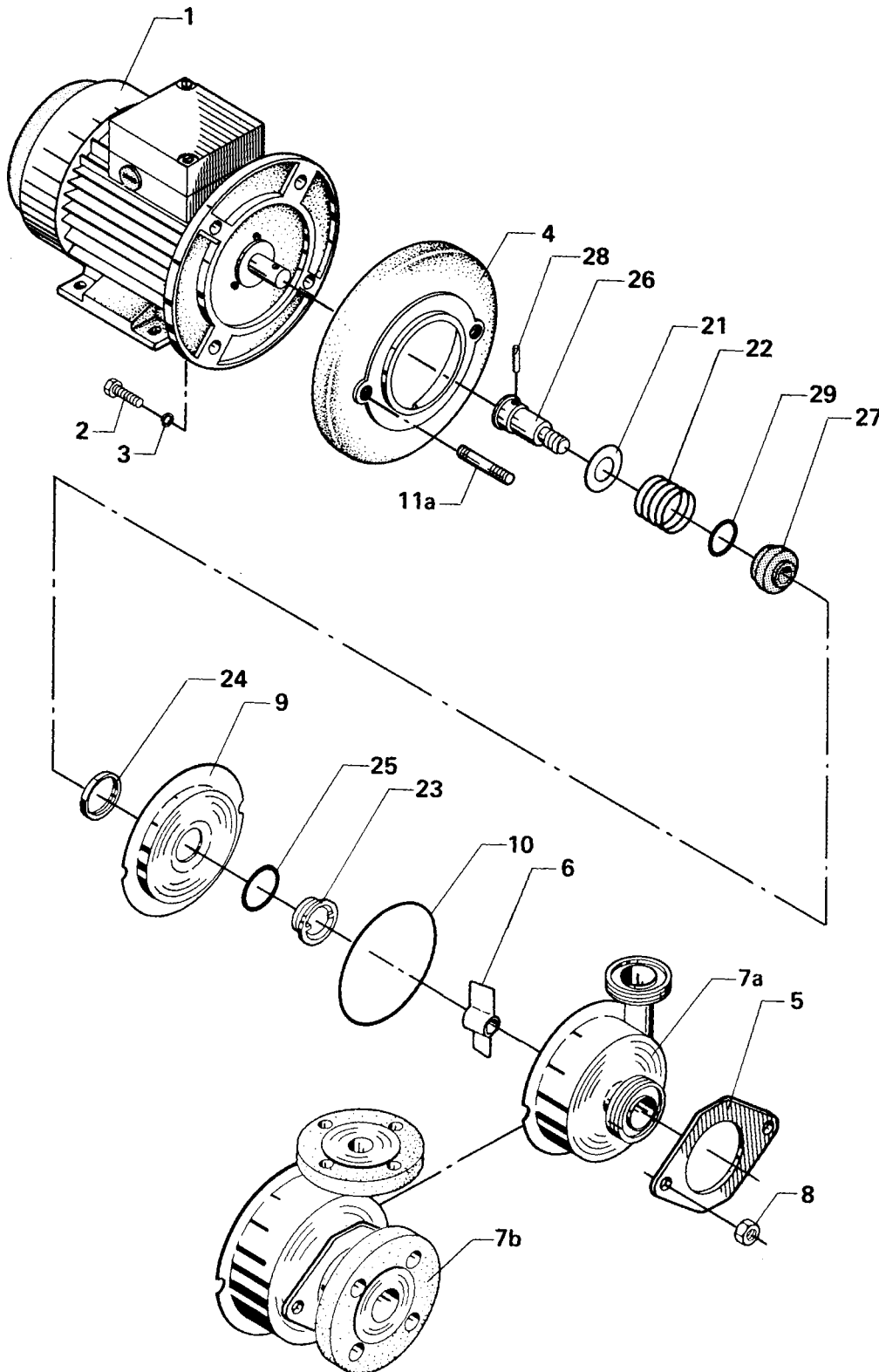

Drawing/Parts list

The drawing and the parts list include all items of the pump.

The items are identical with the items in the Spare Parts List.
When ordering spare parts, please use the Spare Parts List!

Parts List FM-OS, Flushed shaft seal

20

Pos.	Qty.	Denomination
1	1	Motor
2	4	Screw
3	4	Spring washer
4	1	Adaptor
5	1	Yoke
6	1	Impeller
7	1	Pump casing
8	2	Nut
9	1	Black plate
10 Δ	1	O-ring
11	2	Stud bolt
21 \circ	1	Thrower
22 $\Delta \circ$	1	Spring
23	1	Stationary seal ring
24 \circ	1	Nut
25	1	Seal
26 \circ	1	Pump shaft
27 \circ	1	Rotating seal ring
28 \circ	1	Tubular spring pin
29 \circ	1	O-ring
29a \square	1	O-ring, front
29b \square	1	O-ring, back
30 \square	3	Washer
31 \square	1	Spacer
32 \square	1	O-ring
33 \square	1	Stationary seal ring
34 \square	1	Tubular spring pin
35 \square	1	Seal housing
36 \square	2	Rotating seal ring
37 \square	1	Spring
39 \square	4	Srew
39a \square	4	Washer
40 \square	1	O-ring
41 \square	1	O-ring
42 \square	1	Pump shaft
43 \square	1	Fastening ring
44 \square	1	Intermediate flange
45 \square	2	Flushing tube
46 \square	1	Assembly mandrel (not shown)

Δ : Service kit - EPDM, NBR, FPM, PTFE
(See Spare Parts List)

\circ : Single shaft seal only

\square : Flushed shaft seal only

This page shows an exploded drawing of FM-OS with flushed shaft seal.

The drawing includes all items of the pump. They are identical with the items in the Spare Parts List.

Exploded drawing

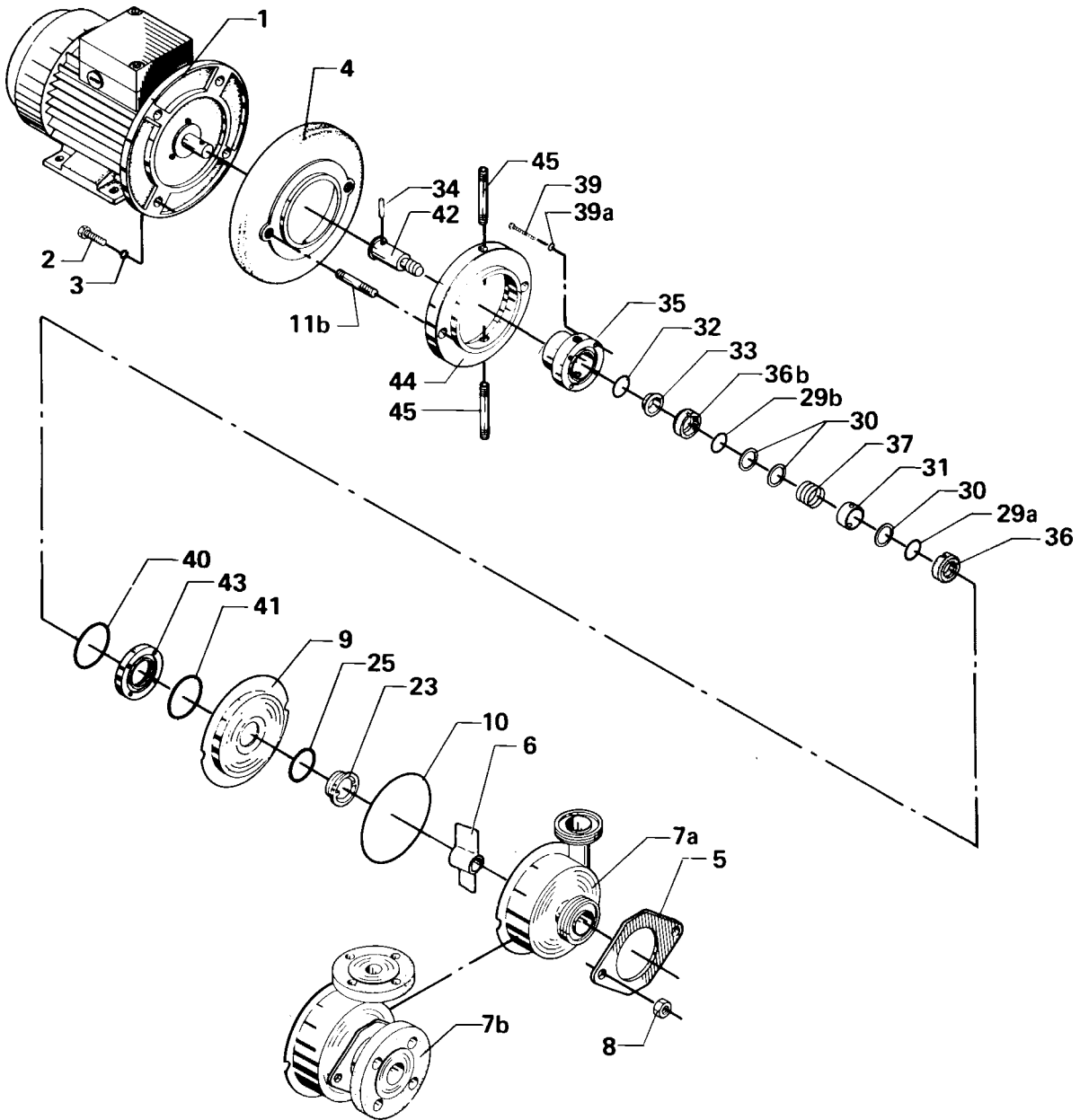

Drawing/Parts list

The drawing and the parts list include all items of the pump.

The items are identical with the items in the Spare Parts List.

When ordering spare parts, please use the Spare Parts List!

Parts List FM-OS

22

Pos.	Qty.	Denomination
1	1	Motor
2	4	Screw
3	4	Spring washer
4	1	Adaptor
5	1	Yoke
6	1	Impeller
7	1	Pump casing
8	2	Nut
9	1	Black plate
10 Δ	1	O-ring
11	2	Stud bolt
21 \circ	1	Thrower
22 Δ \circ	1	Spring
23	1	Stationary seal ring
24 \circ	1	Nut
25	1	Seal
26 \circ	1	Pump shaft
27 \circ	1	Rotating seal ring
28 \circ	1	Tubular spring pin
29 \circ	1	O-ring
29a \square	1	O-ring, front
29b \square	1	O-ring, back
30 \square	3	Washer
31 \square	1	Spacer
32 \square	1	O-ring
33 \square	1	Stationary seal ring
34 \square	1	Tubular spring pin
35 \square	1	Seal housing
36 \square	2	Rotating seal ring
37 \square	1	Spring
39 \square	4	Srew
39a \square	4	Washer
40 \square	1	O-ring
41 \square	1	O-ring
42 \square	1	Pump shaft
43 \square	1	Fastening ring
44 \square	1	Intermediate flange
45 \square	2	Flushing tube
46 \square	1	Assembly mandrel (not shown)

Δ : Service kit - EPDM, NBR, FPM, PTFE
(See Spare Parts List)

\circ : Single shaft seal only

\square : Flushed shaft seal only

The drawing shows FM-OS.

The items refer to the parts list on the part on the page.

Drawings

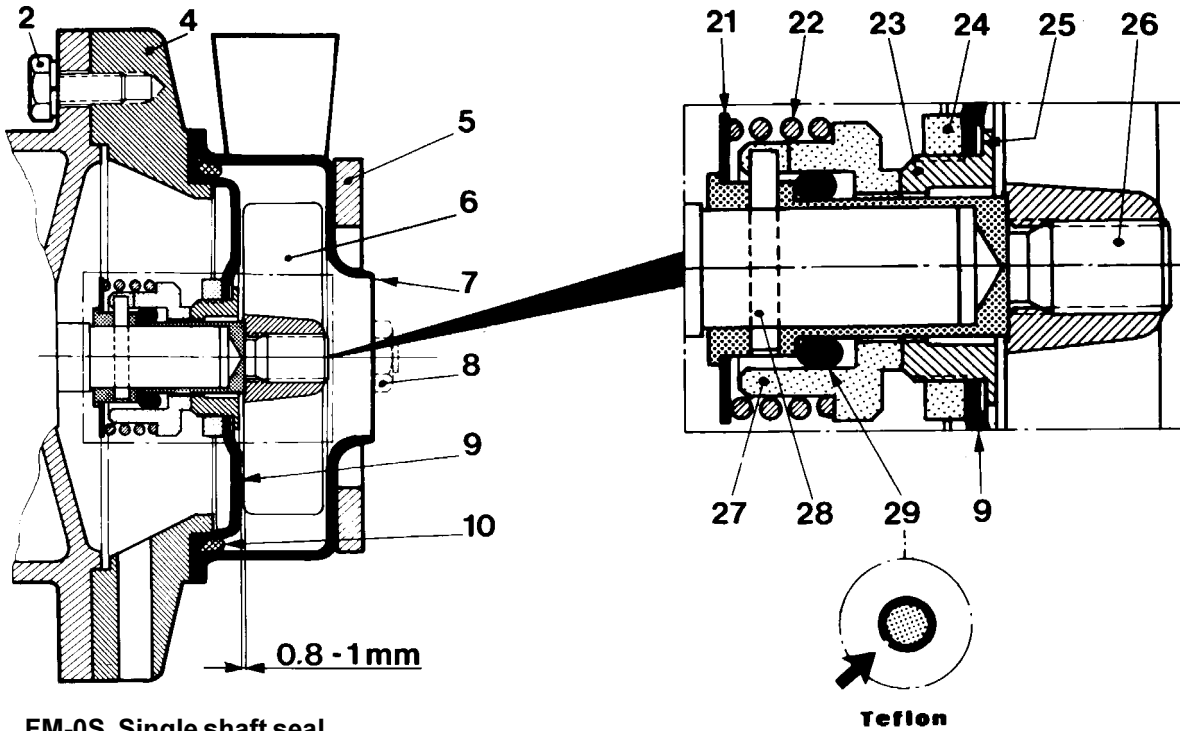

FM-OS, Single shaft seal

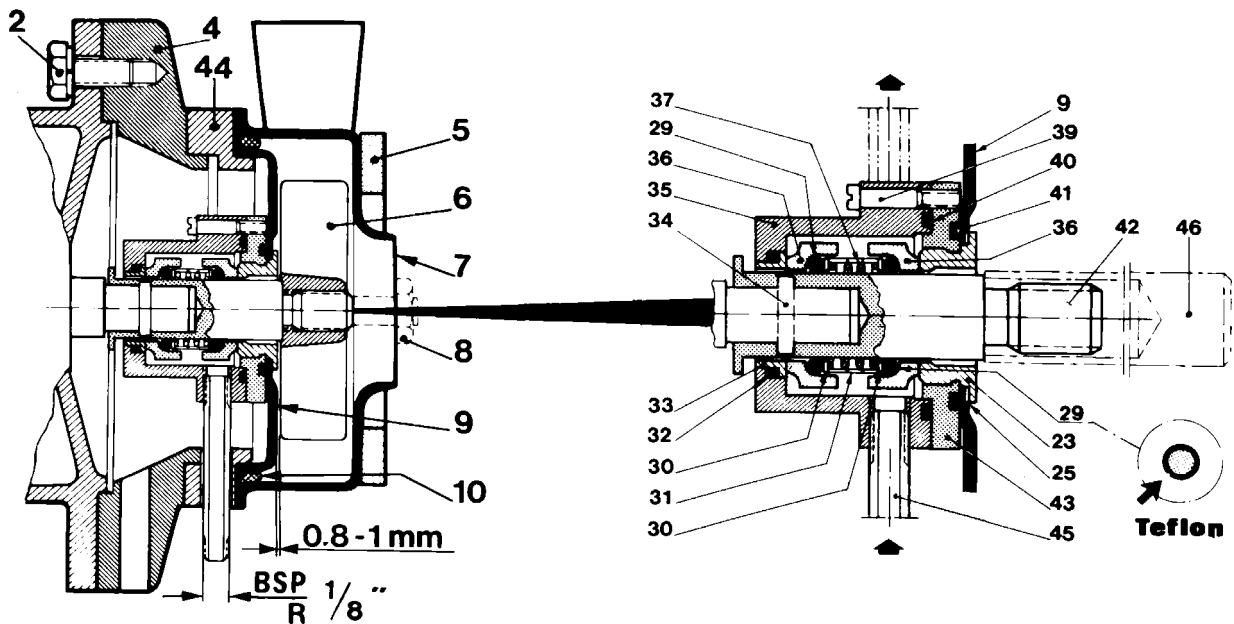

FM-OS, Flushed shaft seal

How to contact Alfa Laval

Contact details for all countries are continually updated on our website. Please visit www.alfalaval.com to access the information direct.