

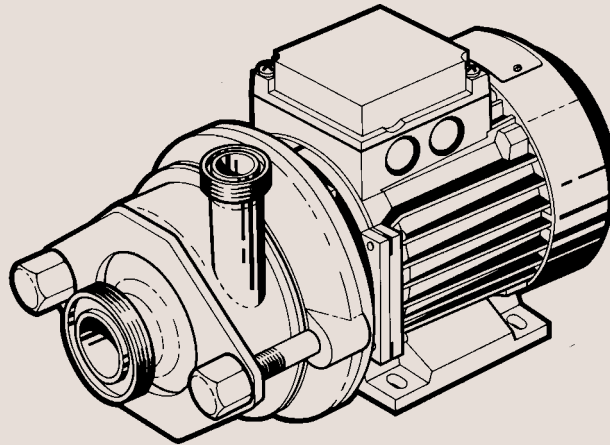

# Instruction Manual

## GM Centrifugal Pump



# Declaration of Conformity

The designating company

**Alfa Laval**

Company Name

**6000 Kolding**

Address

**+45 79 32 22 00**

Phone No.

hereby declare that

**Centrifugal Pump**

Denomination

**GM**

Type

Year

is in conformity with the following directives with amendments:

- Low Voltage Directive 73/23/EEC
- EMC Directive 89/336/EEC
- Machinery Directive 89/392/EEC

**Bjarne Søndergaard**

Name

**Vice President, R & D**

Title

**Alfa Laval**

Company

*B. Søndergaard*

Signature

**Designation**

**CE**

# Table of contents

*This manual is divided into main sections. - See below.*

## **Safety**

1. Important information .....	2
2. Warning signs .....	2
3. Safety precautions .....	3

## **Installation**

1. Unpacking/Delivery .....	4
2. Installation .....	5
3. Pre-use check .....	6

## **Operation**

1. Operation/Control .....	7
2. Fault finding .....	8
3. Recommended cleaning .....	9

## **Maintenance**

1. General maintenance .....	10
2. Dismantling of pump/shaft seal .....	12
3. Assembly of pump/shaft seal .....	14

## **Technical data**

1. Technical data .....	16
-------------------------	----

## **Drawings/Parts list**

1. Parts list .....	18+20+22
2. Exploded drawing .....	19+21
3. Drawing .....	23

# Safety

Unsafe practices and other important information are emphasized in this manual.

Warnings are emphasized by means of special signs.

## 1. Important information

**Always read the manual before using the pump!**

2

- WARNING!** : Indicates that special procedures **must** be followed to avoid severe personal injury.
- CAUTION!** : Indicates that special procedures **must** be followed to avoid damage to the pump.
- NOTE!** : Indicates important information to simplify practices or to make them clearer.

---

## 2. Warning signs



: General warning.



: Dangerous electrical voltage.



: Caustic agents.

All warnings in the manual are summarized on this page.

Pay special attention to the instructions below so that severe personal injury or damage to the pump are avoided.

## 3. Safety precautions

### Installation:



- : **Always** observe the technical data (see page 16).



- : The pump **must** be electrically connected by authorized personnel (see the motor instructions).



- : - **Always** remove the impeller before checking the direction of rotation (GM-A).
- **Never** start the pump if the impeller is fitted and the pump casing removed.

### Operation:



- : **Always** observe the technical data (see page 16).



- : **Never** touch the pump or the pipelines when pumping hot liquids or when sterilizing.



- : **Never** run the pump with both the suction side and the pressure side blocked.



- : **Always** handle lye and acid with great care.

### Maintenance:



- : **Always** observe the technical data (see page 16).



- : **Always** disconnect the power supply when the pump is serviced.



- : - The pump must **never** be hot when serviced.
- The pump and the pipelines must **never** be pressurised when the pump is serviced.

# Installation

4

*The instruction manual is part of the delivery. Study the instructions carefully.*

*GM: Impeller and collets of glassfibre reinforced plastic.*

*GM-A: Impeller and yoke of stainless steel.*

## 1. Unpacking/Delivery

1

### NOTE!

We cannot be held responsible for incorrect unpacking.

### Check the delivery:

1. Complete pump, GM or GM-A.
2. Delivery note.
3. Instruction manual.
4. Motor instructions.
5. Test certificate, IF ORDERED!

3

Inspect the pump for visible transport damage.

5

Always remove the shroud, if fitted, before lifting the pump.

*The standard delivery does not include the test certificate. This can be supplied on request.*

2

Clean the inlet and the outlet from possible packing materials.

4

Avoid damaging the inlet and the outlet.

Study the instructions carefully and pay special attention to the warnings!

Always check the pump before operation.  
- See pre-use check on page 6.

## 2. Installation

1

 **Always** observe the technical data (see page 16).

 The pump **must** be electrically connected by authorized personnel (see the motor instructions).

### NOTE!

We cannot be held responsible for incorrect installation.

2

Ensure that there is sufficient clearance around the pump.

3

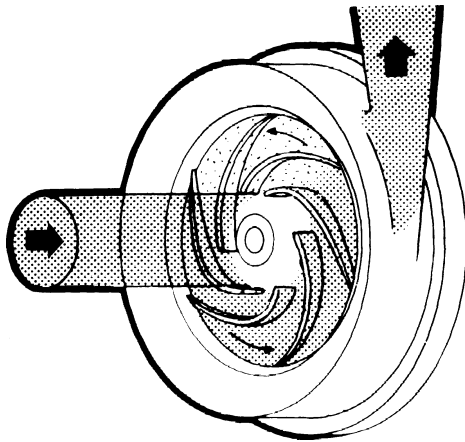

Ensure that the flow direction is correct.

4

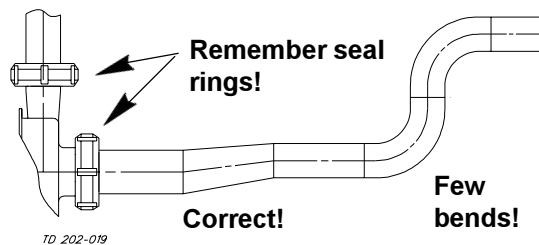

5 Ensure that the pipelines are routed correctly.

2. Ensure that the connections are tight.

### Risk of damage!

Avoid stressing the pump.

Pay special attention to:

- Vibrations.
- Thermal expansion of the tubes.
- Excessive welding.
- Overloading of the pipelines.

# Installation

Study the instructions carefully and pay special attention to the warnings!

GM: Impeller and collets of glassfibre reinforced plastic.

GM-A: Impeller and yoke of stainless steel.

## 3. Pre-use check - GM-A

1



- **Always** remove the impeller before checking the direction of rotation.
- **Never** start the pump if the impeller is fitted and the pump casing removed.

Check the direction of rotation of pump shaft/motor fan before operation.

- See the indication label on the pump.

2

6

Dismantle the pump in accordance with instructions 1-3 and 6 on page 12.

3

**See the indication label!**

4

1. Start and stop the motor momentarily.
2. Ensure that the direction of rotation of pump shaft (7) is **anticlockwise** as viewed from the inlet side.

Assemble the pump in accordance with instructions 5-7 and 9-10 on pages 14-15.

## 3. Pre-use check - GM

**See the indication label!**

1. Start and stop the motor momentarily.
2. Ensure that the direction of rotation of the motor fan is **clockwise** as viewed from the back of the motor.

Study the instructions carefully and pay special attention to the warnings!

The pump is fitted with a warning label indicating correct throttling.

## 1. Operation/Control

1



**Always** observe the technical data (see page 16).

### NOTE!

We cannot be held responsible for incorrect operation/control.

3

**Explosion danger!**

⇒ **See the warning label!**



**Never** run the pump with both the suction side and the pressure side blocked.

5

### Control:

Reduce the capacity and the power consumption by means of:

- Throttling the pressure side of the pump.
- Reducing the impeller diameter.
- Speed control of the motor.

2

**Burning danger!**

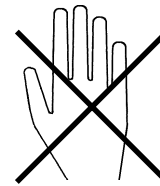

**Never** touch the pump or the pipelines when pumping hot liquids or when sterilizing.

4

### CAUTION!

- The shaft seal must not run dry.
- Never throttle the inlet side.

6

Pay attention to possible faults.

Study the instructions carefully.

## 2. Fault finding

### NOTE!

Study the maintenance instructions carefully before replacing worn parts. - See page 10!

Problem	Cause/result	Repair
Overloaded motor	<ul style="list-style-type: none"> <li>- Pumping of viscous liquids</li> <li>- Pumping of liquids with high density</li> <li>- Low outlet pressure (counter pressure)</li> </ul>	<ul style="list-style-type: none"> <li>- Smaller impeller</li> <li>- Higher counter pressure (throttling)</li> </ul>
Cavitation: <ul style="list-style-type: none"> <li>- Damage</li> <li>- Pressure reduction (sometimes to zero)</li> <li>- Increasing of the noise level</li> </ul>	<ul style="list-style-type: none"> <li>- Low inlet pressure</li> <li>- High liquid temperature</li> </ul>	<ul style="list-style-type: none"> <li>- Increase of the inlet pressure</li> <li>- Reduce the liquid temperature</li> <li>- Reduce the pressure drop before the pump</li> </ul>
Leaking shaft seal	<ul style="list-style-type: none"> <li>- Dry run (See page 7)</li> <li>- Incorrect rubber grade</li> <li>- Abrasive particles in the liquid</li> </ul>	<b>Replace:</b> All wearing parts (See page 10) <ul style="list-style-type: none"> <li>- Select a different rubber grade</li> <li>- Select stationary and rotating seal ring in Silicon Carbide/ Silicon Carbide</li> </ul>
Leaking seals	Incorrect rubber grade	Select a different rubber grade

The pump is designed for cleaning in place (CIP).  
CIP = Cleaning In Place.

Study the instructions carefully and pay special attention to the warnings!  
NaOH = Caustic Soda.  
HNO<sub>3</sub> = Nitric acid.

### 3. Recommended cleaning

1

**Caustic danger!**



**Always** use rubber gloves!



**Always** use protective goggles!



**Always** handle lye and acid with great care.

3

**Examples of cleaning agents:**  
Use clean water, free from chlorides.

1. 1% by weight NaOH at 70°C.

1 kg NaOH	+	100 l water	= Cleaning agent.
--------------	---	----------------	-------------------

2.2 l 33%NaOH	+	100 l water	= Cleaning agent.
------------------	---	----------------	-------------------

2. 0.5% by weight HNO<sub>3</sub> at 70°C.

0.7 l 53% HNO <sub>3</sub>	+	100 l water	= Cleaning agent.
-------------------------------	---	----------------	-------------------

5

**Always!**

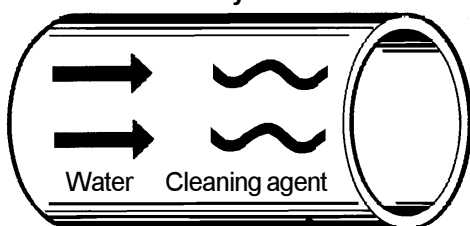

**Always** rinse well with clean water after the cleaning.

2

**Burning danger!**

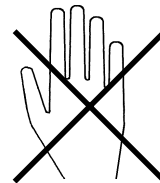

**Never** touch the pump or the pipelines when sterilizing.

4

1. Avoid excessive concentration of the cleaning agent

⇒ **Dose gradually!**

2. Adjust the cleaning flow to the process

**Milk sterilization/viscous liquids**

⇒ **Increase the cleaning flow!**

6

**NOTE!**

The cleaning agents must be stored/discharged in accordance with current rules/directives.

# Maintenance

10

Maintain the pump carefully.  
Study the instructions carefully and pay special attention to the warnings!

Always keep spare shaft seals and rubber seals in stock.  
See separate motor instructions.

## 1. General maintenance

1



**Always** observe the technical data (see page 16).



**Always** disconnect the power supply when the pump is serviced.

### NOTE!

All scrap must be stored/discharged in accordance with current rules/directives.

2

**Burning danger!**

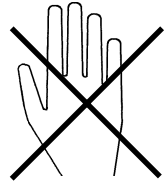

The pump must **never** be hot when serviced.

3



The pump and the pipelines must **never** be pressurised when the pump is serviced.

4

### CAUTION!

Fit the electrical connections correctly if they have been removed from the motor during service (see pre-use check on page 6).

**Pay special attention to the warnings!**

## Ordering spare parts

- Contact the Sales Department.
- Order from the Spare Parts List.

**Recommended spare parts: Service kits (see Spare Parts List).**

Maintain the pump carefully.  
 Study the instructions carefully.  
 Always keep spare shaft seals and rubber seals in stock.

See separate motor instructions.  
 Check the pump for smooth operation after service.

## 1. General maintenance

	Shaft seal	Rubber seals	Motor bearings
Preventive maintenance	<b>Replace after 12 months:</b> (one-shift) Complete shaft seal	Replace when replacing the shaft seal	
Maintenance after leakage (leakage normally starts slowly)	<b>Replace at the end of the day:</b> Complete shaft seal	Replace when replacing the shaft seal	
Planned maintenance	<ul style="list-style-type: none"> <li>- Regular inspection for leakage and smooth operation</li> <li>- Keep a record of the pump</li> <li>- Use the statistics for planning of inspections</li> </ul> <b>Replace after leakage:</b> Complete shaft seal	Replace when replacing the shaft seal	Yearly inspection is recommended - Replace complete bearing if worn
Lubrication	<b>Before fitting</b> Lubricate the O-rings with silicone grease or silicone oil (not the sealing surfaces)	<b>Before fitting</b> Silicone grease or silicone oil	<b>None</b> The bearings are permanently lubricated

# Maintenance

Study the instructions carefully.  
The items refer to the drawings and the parts list on  
pages 18-23.

Handle scrap correctly.

12

## 2. Dismantling of pump/Removing the shaft seal (1-6★)

1



1. Remove cap nuts (13).
2. Remove collets (14a), (only GM), or yoke (14b), (only GM-A)
3. Remove pump casing (11) and O-ring (10), (use a plastic hammer, if necessary).

3



2



1. Remove impeller (9) by pulling it off pump shaft (7), (only GM).
2. Turn impeller (9) anticlockwise and remove it from the pump shaft (only GM-A). Use a plastic hammer if necessary.

4



1. Remove back plate (8).
2. The shaft seal is now accessible.

5



Turn nut (22) **clockwise** and remove it from stationary seal ring (23).

6



Remove stationary seal ring (23) and seal (26) from back plate (8).

Remove the rest of the shaft seal from pump shaft (7).

*Study the instructions carefully.  
The items refer to the drawings and the parts list on  
pages 18-23.*

*Handle scrap correctly.*

## 2. Dismantling of pump/Removing the shaft seal (1-6\*)

---

**7**

---

**8**

If fitted, remove the shroud.

---

**9**

- 
1. Remove nuts (2).
  2. Remove adaptor (4) from the motor.

---

**10**

---

Remove thrower (5) from pump shaft (7).

- 
1. Knock out pin (6).
  2. Pull off pump shaft (7).

# Maintenance

Study the instructions carefully.  
The items refer to the drawings and the parts list on pages 18-23.

Lubricate the rubber seals before fitting them.

## 3. Assembly of pump/Fitting the shaft seal (5-10★)

1

1. Fit pump shaft (7) on the motor shaft.
2. Lock the pump shaft with pin (6).

3

If supplied, fit the shroud.

5

Fit spring (19), spacer (20) and washer (21) on pump shaft (7).

2

1. Fit adaptor (4) on the motor.
2. Fit and tighten nuts (2).

**NOTE!**

Ensure that the adaptor drain hole is turned downwards.

4

1. Fit thrower (5) on pump shaft (7).
2. Lubricate the external surface of the pump shaft.

6

Fit O-ring (24) on pump shaft (7).

**NOTE!**

Ensure correct position of the joint when Teflon O-rings are used.

Study the instructions carefully.  
The items refer to the drawings and the parts list on pages 18-23.

Lubricate the rubber seals before fitting them.

### 3. Assembly of pump/Fitting the shaft seal (5-10★)

7

★

Push seal ring (25) as far as possible over O-ring (24).  
**NOTE!**  
Push and pull until the O-ring is correctly positioned.

9

★

1. Push impeller (9) on pump shaft (7), (only GM).
2. Fit impeller (9) on pump shaft (7), turn it clockwise and tighten (only GM-A).

8

★

1. Fit seal (26) and stationary seal ring (23) in back plate (8).
2. Fit nut (22), turn it **anticlockwise** and tighten.
3. Fit the back plate on adaptor (4).

10

★

1. Fit O-ring (10) and pump casing (11) on back plate (8).
2. Fit collets (14a) (only GM), or yoke (14 b), (only GM-A).
3. Fit and tighten cap nuts (13).



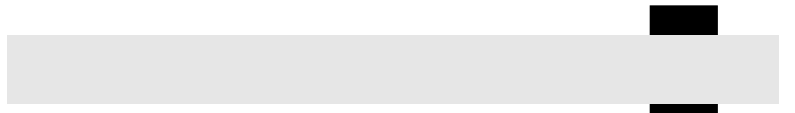

# Drawing/Parts list

The drawing and the parts list include all items of the pump.

The items are identical with the items in the Spare Parts List.

When ordering spare parts, please use the Spare Parts List!

## Parts list

GM

18

Pos.	Qty.	Denomination
1	1	Motor
2	4	Nut
3	4	Stud bolt
4	1	Adaptor
5	1	Thrower
6	1	Tubular spring pin
7	1	Pump shaft
8	1	Black plate
9	1	Impeller
10 Δ	1	O-ring
11	1	Pump casing
12	2	Stud bolt
13	2	Cap nut
14a	2	Collet
14b	1	Yoke
15	1	Legs, complete (optional extra)
16	4	Nut (optional extra)
17	4	Washer (optional extra)
18	4	Screw (optional extra)
19 Δ	1	Spring
20 Δ	1	Spacer
21 Δ	1	Washer
22	1	Nut
23 Δ	1	Stationary seal ring
24 Δ	1	O-ring
25 Δ	1	Rotating seal ring
26 Δ	1	Seal

Δ : Service kit - EPDM, NBR, FPM, PTFE  
(See Spare Parts list)

This page shows an exploded drawing of GM.  
GM: Impeller and collets of glassfibre reinforced plastic.

The drawing includes all items of the pump.  
They are identical with the items in the Spare Parts List.

## Exploded drawing

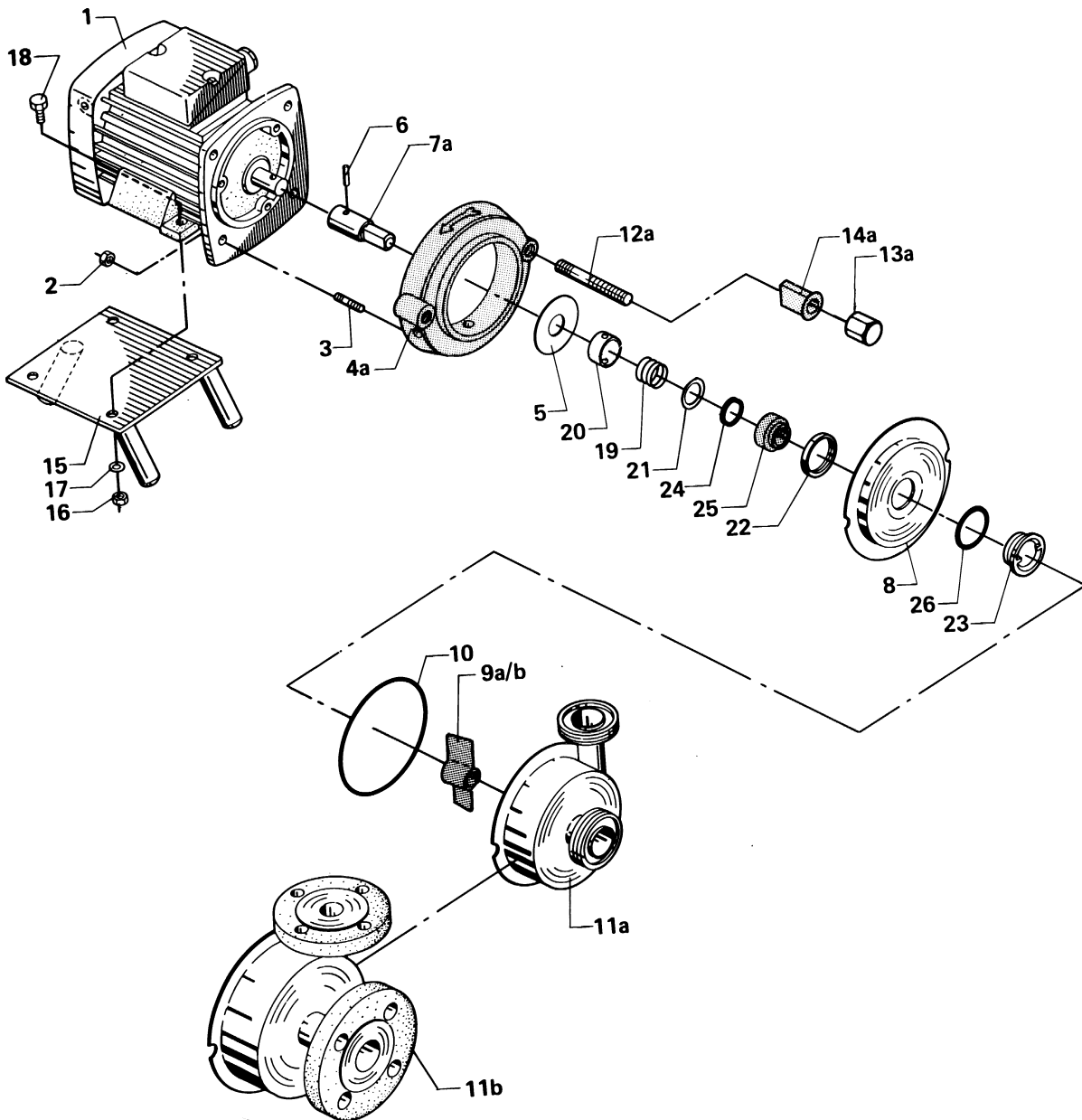

## Drawing/Parts list

The drawing and the parts list include all items of the pump.

The items are identical with the items in the Spare Parts List.

When ordering spare parts, please use the Spare Parts List!

### Parts list GM-A

20

Pos.	Qty.	Denomination
1	1	Motor
2	4	Nut
3	4	Stud bolt
4	1	Adaptor
5	1	Thrower
6	1	Tubular spring pin
7	1	Pump shaft
8	1	Black plate
9	1	Impeller
10 Δ	1	O-ring
11	1	Pump casing
12	2	Stud bolt
13	2	Cap nut
14a	2	Collet
14b	1	Yoke
15	1	Legs, complete (optional extra)
16	4	Nut (optional extra)
17	4	Washer (optional extra)
18	4	Screw (optional extra)
19 Δ	1	Spring
20 Δ	1	Spacer
21 Δ	1	Washer
22	1	Nut
23 Δ	1	Stationary seal ring
24 Δ	1	O-ring
25 Δ	1	Rotating seal ring
26 Δ	1	Seal

Δ : Service kit - EPDM, NBR, FPM, PTFE  
(See Spare Parts list)

This page shows an exploded drawing of GM-A.  
GM-A: Impeller and yoke of stainless steel.

The drawing includes all items of the pump.  
They are identical with the items in the Spare Parts List.

## Exploded drawing

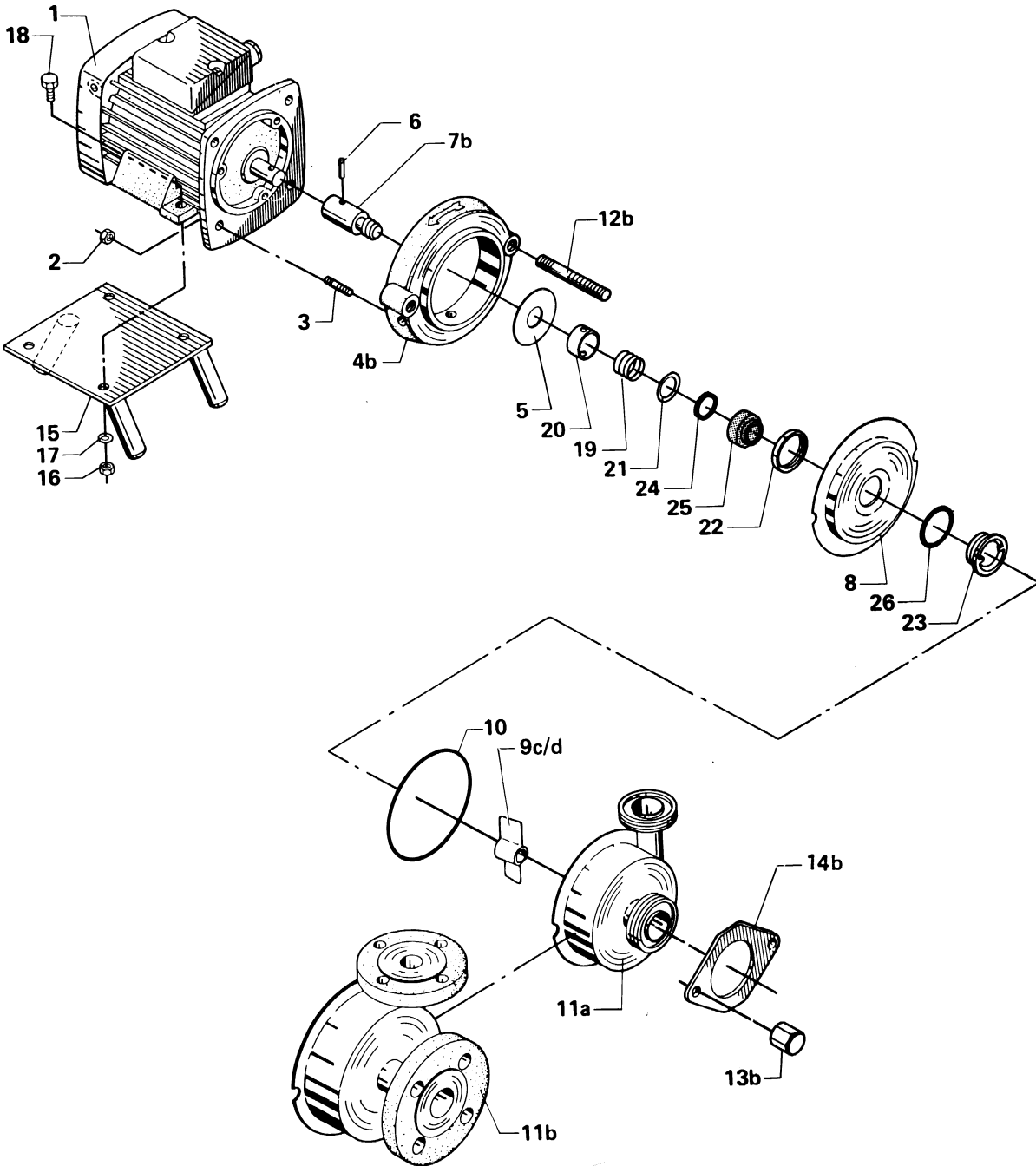

## Drawing/Parts list

The drawing and the parts list include all items of the pump.

The items are identical with the items in the Spare Parts List.

When ordering spare parts, please use the Spare Parts List!

### Parts list

GM

22

Pos.	Qty.	Denomination
1	1	Motor
2	4	Nut
3	4	Stud bolt
4	1	Adaptor
5	1	Thrower
6	1	Tubular spring pin
7	1	Pump shaft
8	1	Black plate
9	1	Impeller
10 Δ	1	O-ring
11	1	Pump casing
12	2	Stud bolt
13	2	Cap nut
14a	2	Collet
14b	1	Yoke
15	1	Legs, complete (optional extra)
16	4	Nut (optional extra)
17	4	Washer (optional extra)
18	4	Screw (optional extra)
19 Δ	1	Spring
20 Δ	1	Spacer
21 Δ	1	Washer
22	1	Nut
23 Δ	1	Stationary seal ring
24 Δ	1	O-ring
25 Δ	1	Rotating seal ring
26 Δ	1	Seal

Δ : Service kit - EPDM, NBR, FPM, PTFE  
(See Spare Parts list)

The drawing shows GM.

The items refer to the parts list on the opposite part of the page.

## Drawing

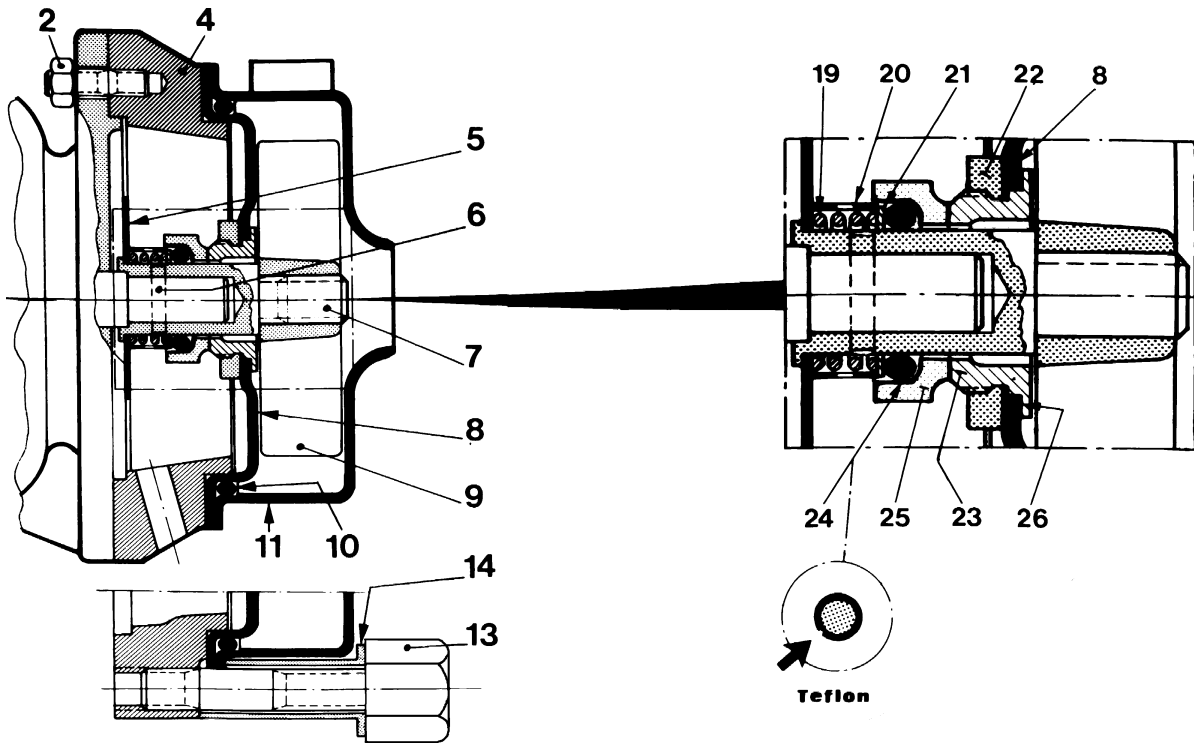

**How to contact Alfa Laval**

Contact details for all countries are continually updated on our website. Please visit [www.alfalaval.com](http://www.alfalaval.com) to access the information direct.