



Leave Surveillance to the Top

ThinkTop® Basic Intrinsically Safe II 2G EEx ia IIC T6

Application

The ThinkTop Basic Intrinsically Safe is designed to ensure optimum valve control in conjunction with Alfa Laval sanitary valves and it is compatible with all major PLC systems (Programmable Logic Controller). It is for use in Breweries, Personal Care, Chemical, Biopharmaceutical installations and in Pharmaceutical applications.

The ThinkTop Basic Intrinsically Safe is a fully equipped control unit that complies with the ATEX Directive 94/9/EC and applies to equipment and protective systems, like all ancillary sanitary processing valves used in areas endangered by potentially explosive atmospheres.

According to the ATEX directive the ThinkTop Basic Intrinsically Safe is approved and classified under Group II, Category 2 (Gas) and Category 3 (Gas) and explosion group II 2G EEx ia IIC T6.

Working Principle

The ThinkTop Basic Intrinsically Safe consists of NC inductive NAMUR sensors and solenoid valves to control processing valves. It is used to control and supervise pneumatic valves and is mounted on top of the valve. It receives signals from a PLC to control the solenoid valve and it returns the valve status signals back to the PLC.

The ATEX addendum EC declaration of conformity is part of the Instruction Manual. It is important that the end user reads this PD sheet prior to start up.

Electrical Signals

To comply with the ATEX protective system all individual electrical signals from the control unit must be connected to an electrical barrier in the safe area to obtain the intrinsic safe circuit. The electrical barrier must comply with the standard EN 60079-14.

The valve positions are detected by the inductive NAMUR sensor 8 VDC working as NC (Normally Closed) and PNP or NPN interface is available as mechanical setup on the electrical barrier.



ThinkTop® Basic Intrinsically Safe

Standard Design

The ThinkTop has a simple, modular and robust design which ensures a quick and easy assembly/disassembly. It consists of a base containing a frame carrying the sensors, an indication pin, terminals for internal electrical connection, solenoid valves and a shell. See also Fig. 1 "Basic Intrinsically Safe Design". The design is hygienic and easy to clean.

Important!

It will be the responsibility of the end user to perform the explosion risk assessment and to classify the group and the corresponding zone (dust or gas) in accordance with the Directive 1999/92/EC.



II 2G EEx ia IIC T6

Micro environment demand specifications

Temperature		
Working:	-10°C to +45°C	EN 50020
Storage:	-40°C to +85°C	IEC 68-2-1/2
Temperature change:	-25°C to +70°C	IEC 68-2-14
Vibration	10-55 Hz, 0.7 mm 55-500 Hz, 10g 3 x 30 min, 1 octave/min	IEC 68-2-6
Drop test		IEC 68-2-32
Humidity		
Constant humidity:	+40°C, 21 days, 93% R.H.	IEC 60068-2-78
Cyclic humidity:	+15°C/+45°C 12 cycles	EN 60068-2-30 IEC 68-2-30
(working)	93% R.H.	
Protection class	IP66 and IP67	EN 60529
Surface resistance	< 1GΩ	EN 60079-0
Type of explosion group	Ex II 2G EEx ia IIC T6	ATEX directive 94/9/EC

The ThinkTop Basic Intrinsically Safe must always be installed in an intrinsic safe circuit.

Sensor
The two inductive NAMUR sensors must be connected to a certified intrinsically safe circuit (e.g. Zener barrier) for apparatus group IIC with the following maximum values:

$U_i = 15V$
 $I_i = 50mA$
 $P_i = 1W$
 $L_i = 100\mu H$
 $C_i = 100nF$

Solenoid valve
The intrinsic safe solenoid valves must also be connected to a certified intrinsically safe circuit (e.g. Zener barrier) for apparatus group IIC with the following maximum values:

$U_i = 28V$
 $I_i = 225mA$
 $P_i = 1W$
 $L_i = 0\mu H$
 $C_i = 0nF$

The electrical installation of ThinkTop Basic Intrinsically Safe must be done according to the standard EN 60079-14.

Safe Area

Hazardous Area - Zone 1

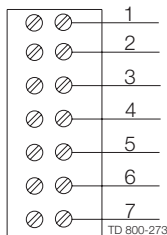

Electrical connections, internal

1. Sensor 1 [De-energized] (blue) 8 VDC
2. Sensor 1 [De-energized] (brown)
3. Sensor 2 [Energized] (blue) 8 VDC
4. Sensor 2 [Energized] (brown)
5. Common; solenoids (black) 12 VDC
6. Input; solenoid #1 (red)
7. Input; solenoid #3 (red)

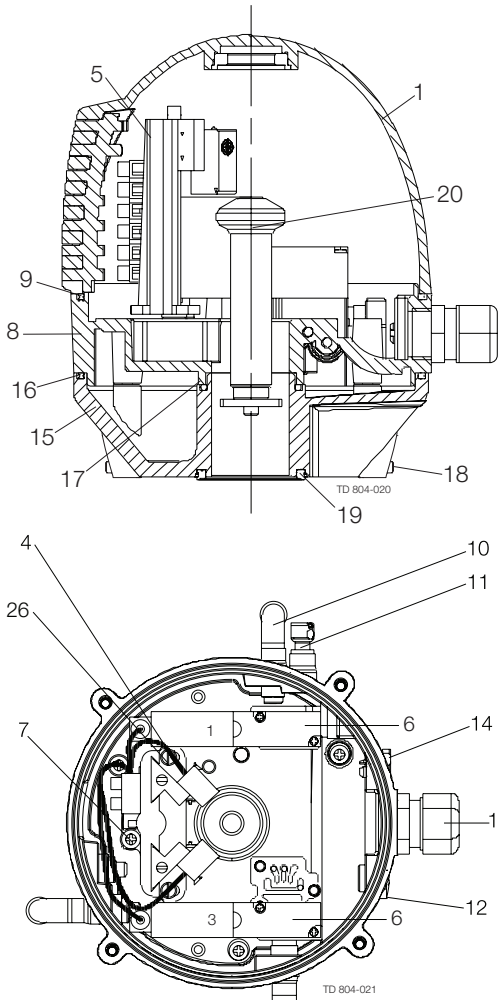

- 1. Shell
- 4. Washer
- 5. Frame cpl. with sensors
- 6. Solenoid valve (3/2)
- 7. PT screw
- 8. Base
- 9. Special X-ring, grey
- 10. Air fittings
- 11. Blow-off valve
- 12. Thread plug, PG7
- 13. Cable gland, PG11
- 14. Gore Vent. membrane
- 15. Adapter
- 16. Special X-ring, black
- 17. O-ring
- 18. Allen screw
- 19. Special X-ring
- 20. Indication pin
- 26. Screw

Fig. 1. Basic Intrinsically Safe design, ThinkTop Basic Intrinsically Safe.

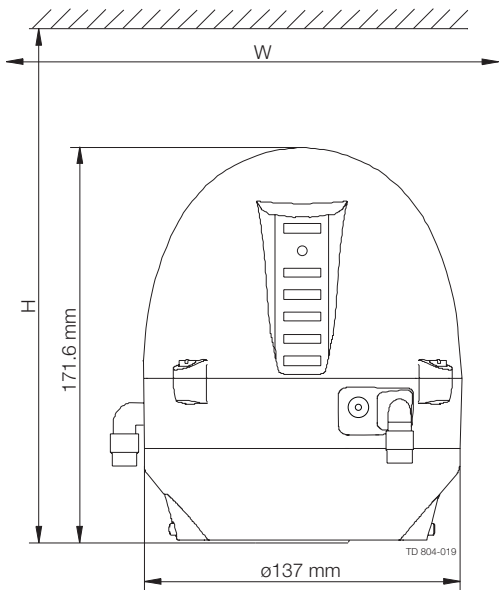

Fig. 2. Dimensions.

Note! This is the basic design.		
Valve Type	H	W
Unique SSV ATEX NC	225	250
SRC NC	225	250
SMP-SC/-BC/-TO	225	250
Unique Mixproof	225	250
Koltek MH	225	250
SBV	225	250
Unique SSV ATEX NO	225	320
SRC NO	225	320
LKLA-T	225	300

Ordering

Please state the following when ordering:

- ThinkTop Basic Intrinsically Safe
- Number of solenoids (0-2)
- Air connection $\varnothing 6$ mm or 1/4"
- ThinkTop Basic Intrinsically Safe does not support Unique SSV-LS and SRC-LS

Note!

For further details, see also instruction manual ESE00810.

ESE00812EN 0904

The information contained herein is correct at the time of issue,
but may be subject to change without prior notice.

How to contact Alfa Laval

Contact details for all countries
are continually updated on our website.
Please visit www.alfalaval.com to
access the information direct.