

Leave Surveillance to the Top

ThinkTop® AS-Interface 29.5 - 31.6 VDC

Application

The *ThinkTop*® is designed to ensure optimum valve control in conjunction with Alfa Laval sanitary valves and it is compatible with all major PLC systems (Programmable Logic Controller with AS-interface). It is for use in food, dairy and brewery installations and in biopharmaceutical applications.

Working Principle

The *ThinkTop*® is a control head including indication units and solenoid valves to control all kinds of processing valves. It is used to control and supervise pneumatic valves and it is mounted on top of the valve. It receives signals from a PLC to control the valve and it sends feedback signals to the PLC to indicate when the valve is in a certain position.

To adapt the sensor unit to the specific valve and to the application, the user sets up the *ThinkTop*® either by the local keys or by using the key pad (which is ordered separately). When using the key pad it is not necessary to dismantle the top unit.

Sensor System

Unique "No Touch" sensor system without any mechanical sensor adjustments. A magnet is mounted on the valve stem and the magnetic field (axial) is detected by sensor chips inside the sensor unit. The measuring angle from each chip is used to locate the current position of the valve stem with an accuracy of $\pm 0.1\text{mm}$. Note that the distance to the magnet can be $5\text{ mm} \pm 3\text{ mm}$.

Feedback Signals

The sensor system can be used for 3 feedback signals + 1 status signal = 4 feedback signals. 2 of the feedback signals can be external sensors if necessary.

The status signal is used for detection of the following:

- Set-up is in progress.
- Internal error.
- Maintenance is required (based on time and/or the self adjustment programme).

The LEDs are constantly indicating the status of the unit: Valve



Fig. 1. *ThinkTop*®

position, solenoid activated, setup and local fault indication, maintenance and seat-lift.

Standard Design

The *ThinkTop*® has a simple, modular and robust design which ensures a quick and easy assembly/disassembly. It consists of a base containing a sensor unit with LEDs, an activator stem, terminals for internal electrical connection, solenoid valves and a shell. See also Fig. 2 "Basic Design". It is prepared for upgrading and is exchangeable. The design is hygienic and easy to clean.

Features

Tolerance Programmes

Individual tolerance programmes for all Alfa Laval sanitary valve types are part of the *ThinkTop*® concept ensuring correct feedback to the PLC for open and closed valve position. If the function is disabled the tolerance band will be ± 5 mm.

Self Adjustment (SRC/ARC valves only)

The self adjustment feature is an exceptional aspect of the *ThinkTop*® design. A programme can be activated to allow an adjustment of the tolerance band if the seals in the valve are being compressed or are worn. When the tolerance band of the unit has been adjusted 0.3 mm, an alert warning will appear in the form of a status signal and a flashing maintenance LED. After 0.5 mm adjustment an alarm warning appears: Loss of feedback signal, status signal and steady maintenance light indicating that a replacement of the seal is necessary.

Built-in Maintenance Monitor

The unit can be preset to indicate when the time for maintenance of the valve has been reached. A status signal and flashing maintenance LED can be programmed to return after 3, 6, 9 or 12 months or more.

Other Features

Another very important fact is that the setup is kept until programmed otherwise even during failure in the power supply.

The accurate sensor system enables indication of seatlift to be integrated in the top unit.

Materials

Plastic parts:	Nylon PA 12.
Steel parts:	Stainless steel AISI 304 and 316.
Seals:	Nitrile (NBR). EPDM rubber for SMP-EC activator stem.

Technical Data

Sensor System:

Sensor accuracy:	$\pm 0,1$ mm
Distance to magnet:	5 ± 3 mm
Stroke length:	0.1 - 80 mm

Electrical connection

Direct cable gland entry (hard wired) PG11 ($\varnothing 4 - \varnothing 10$ mm).

Terminals

The terminal row of the sensor unit is equipped with screw terminals for both internal as well as external cables and wires. The terminals are suitable for wires up to 0.75 mm² (AWG 19).

Power Supply - DC

The power supply to the complete unit is taken from the AS-Interface. The unit is reverse polarity protected.

Supply voltage:	29.5 - 31.6 VDC
Supply current:	Max. 45 mA (for sensor unit alone, excluding current to the solenoids and the external proximity switches).

The fulfilling of the UL requirements in UL508 requires that the unit is supplied by an isolating source complying with the requirements for class 2 power units (UL1310) or class 2 and 3 transformers (UL1585).

Feedback Signals

Signals transmitted over the AS-Interface BUS to the AS-Interface master PLC.

External Sensors

The external sensors are used for seat-lift supervision when seat-lift cannot be internally detected. The sensors get their supply voltage from the terminal row. The output signals from the sensors are connected to two inputs on the terminal row on the internal sensor unit. If the actual setup is set for internal seat-lift, the corresponding external signal is not used, otherwise the external signal logically controls the corresponding feedback to the PLC (Programmable Logic Controller).

Supply voltage:	As specified for the AS-Interface (typical 24 VDC)
Supply current:	Max. 15 mA per sensor.
Type of sensor:	VDC, only 3-wire sensor PNP.
Cable length:	Max. 3 m.

Default slave address: 0

I/O code: 7 (4 bit bi-directional)
I/D code: F (slave without profile)
P = F.7.

No. of nodes:

Max. 31 *ThinkTops*® on a single master/gateway

ASI-bus bit assignment

For the AS-Interface version, the following bit assignment will be used:

Input bit 0	- Feedback #1 Closed position:
Output bit 0	- Not connected
Input bit 1	- Feedback #2 Open position:
Output bit 1	- Solenoid valve 1
Input bit 2	- Feedback #3-4 Seat 1 or 2 position:
Output bit 2	- Solenoid valve 2
Input bit 3	- Feedback #5 Status:
Output bit 3	- Solenoid valve 3

Solenoid valves:

Up to 3 solenoid valves in each unit.

Type	3/2 or 5/2 valve (only possible with one 5/2 valve).
Air supply	300-900 kPa (3-9 bar).
Filtered air, max. particles or dirt	0.01 mm.
Max. flow	180 l/min.
Max. oil content	1.0 ppm.
Max. water content	0.0075 kg/kg air.
Throughput	ø2.5 mm.
Air restriction (throttle function) air inlet/outlet.	
Manual hold override.	
External air tube connection	ø6 mm or 1/4".
Silencer/filter **)	Connection possible via ø6 mm or 1/4".
Nominal voltage	24 VDC.
Nominal power	1.0 W.

**) Filter recommended in tropical regions.

Micro environment demand specifications:

Temperature Working: Storage: Temperature change:	-20°C to +85°C -40°C to +85°C -25°C to +70°C	IEC 68-2-1/2 IEC 68-2-1/2 IEC 68-2-14
Vibration	10-55 Hz, 0.7 mm 55-500 Hz, 10g 3 x 30 min, 1 octave/min	IEC 68-2-6
Drop test		IEC 68-2-32
Humidity Constant humidity: Cyclic humidity: (working)	+40°C, 21 days, 93% R.H. +25°C/+55°C 12 cycles 93% R.H.	IEC68-2-3 IEC 68-2-30
Protection class	IP67	IEC 529
Input treshold Voltage/current:	Type 1 input requirements	EN 61131-2
EMC Directive	89/336/EEC	EN 50081-1, EN 50082-2
AS-Interface	Version 2.11*)	EN50295
UL Approval	8-30 VAC/VDC, class 2 input, 45 mA max. output	UL508 - E203255

*) Max. 31 ThinkTops® on a single master/gateway.

AS-Interface Standard Specification Overview (EN50295)**Medium**

Unshielded two-wire cable for data and energy (30 VDC/typical up to 8A for the bus).

Length of bus cable

100 m max. (300 m with repeaters).

Number of slaves

31 max. (each slave has its own address).

Number of participants

Up to 4 sensors and 4 actuators per slave (max. 124, bidirectional = max. 248 binary participants).

Addresses

Each slave has a unique address. The address is set by the master or by a "handheld" programmer.

Messages

The master transmits to each single address in turn with immediate response from each slave.

Bit-rate

4 bits (net) per slave and message.

Cycle time with 31 slaves

5 ms.

Error detection

Incorrect messages are reliably identified and repeated.

Device-interface

4 configurable data ports (as inputs or bidirectional) plus 4 parameter outputs and 2 control outputs (strobe).

Process data in the master

Cyclic polling of all participants.

Cyclic transmission of data to the host or to the slaves respectively.

Master services

Initiation of the network.

Identification of participants.

A cyclic setting of parameter values to the slaves.

Diagnosis of bus and AS-Interface slaves.

Error messages to the host.

Setting of addresses in replaced slaves.

Signal Coding

AS-Interface uses a master code in which a negative \sin^2 pulse represents a falling edge and a positive \sin^2 pulse represents a rising edge. This neutralizes RFI effects and allows unscreened two-wire cable to carry both power and data reliably.

Electrical connection, internal

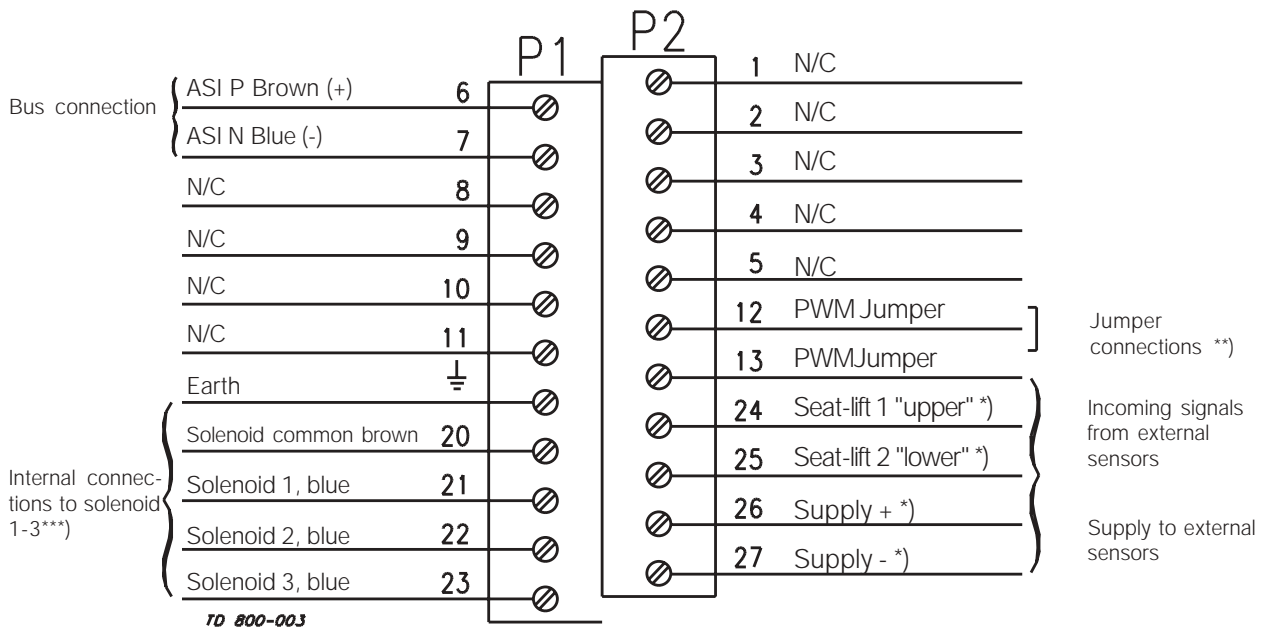

*) **Note!** Terminals 24, 25, 26 and 27 can be used for external seat-lift sensors as well as for any digital input. Always use an external PNP sensor. 2 external signals can be connected, they are associated with feedback signal 3 (seatlift 1) and 4 (seatlift 2). External sensor must always be a 8-30 VDC PNP 3 wire sensor. Connect (-) common on terminal 27, and (+) common on terminal 26. The signals from the external sensors are associated as follows: sensor signal on terminal 24 (seatlift 1) associated with feedback 3 (seatlift 1), and sensor signal on terminal 25 (seatlift 2) associated with feedback 4 (seatlift 2).

***) **Note!** Jumper present = PWM mode (pulse width modulated "on" solenoid valve).

) **Note! Internal connections: Terminals for connection for the solenoids mounted internally in the control head. The number of solenoids actually mounted in the control head could be 0 - 3. The signals are taken directly from the terminal row.

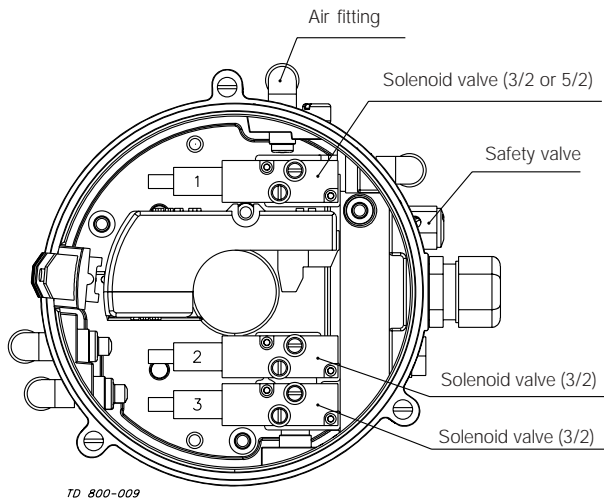
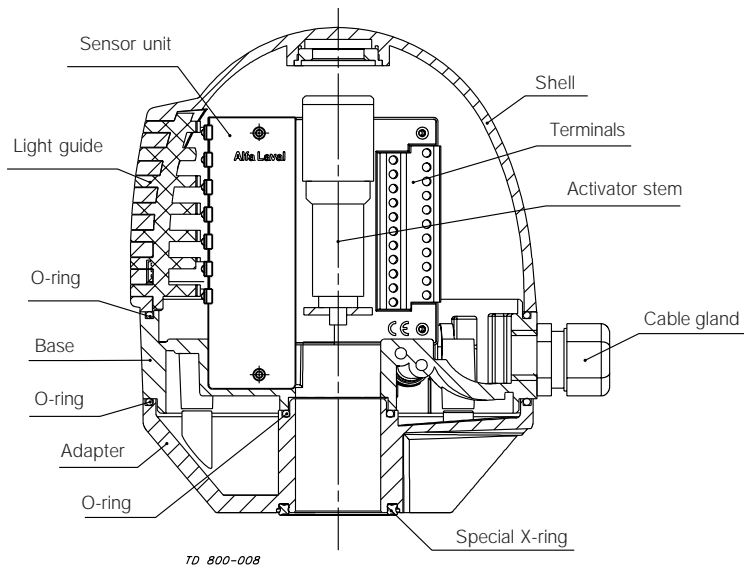

Fig. 2. Basic design, ThinkTop®.

Note! The ThinkTop® for the SMP-EC valve has a longer activator stem which is going through the shell (see Ordering Leaflet).

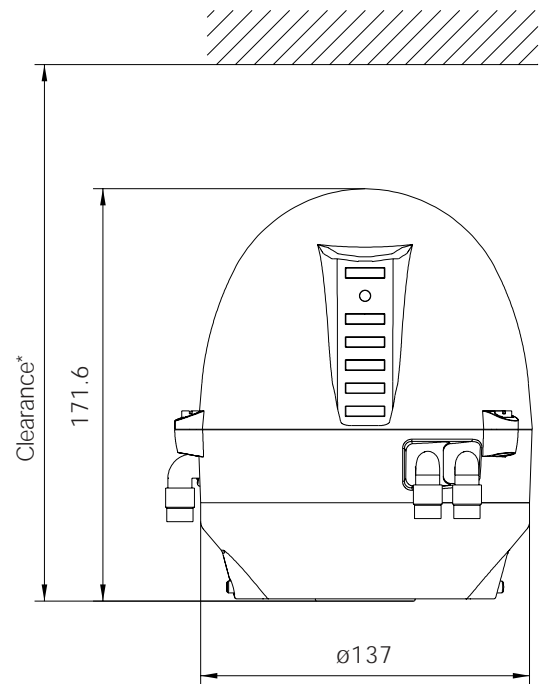

Fig. 3. Dimensions.

***Note!** This is the basic design. The clearance should be approximately:
 ø225 x 250 mm (SRC NC, SMP-SC/-BC/-TO, *Unique*, Koltek MH, SBV, AMP)
 ø225 x 320 (SRC NO)
 ø225 x 300 (LKB/LKLA-T)

Options

- 2m cable (2 x 0.5 mm²) with ASI flat cable connector (Hirschmann).

Accessories

- IR keypad.
- External indication bracket for SMP-SC.
- External indication bracket for *Unique*.

Note! For further information: See also IM 70827.

Note! The *ThinkTop®* has Patented Sensor System, Registered Design and Registered Trademark.

Ordering

Please state the following when ordering:

- AS-Interface 29.5 - 31.6 VDC.
- Number of solenoids (0-3).
- Type of valve (3/2, 5/2).
- Air connection ø6mm or 1/4"
- Please state if SMP-EC or for series 700 valves.