

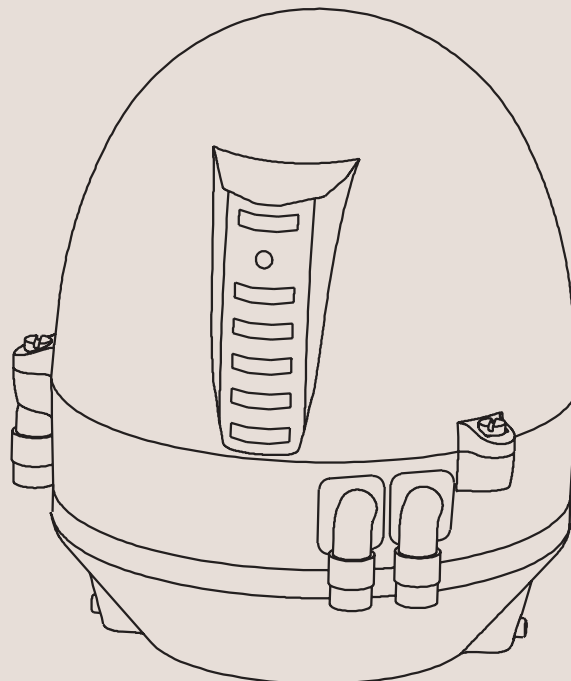

Instruction Manual

ThinkTop® Digital 8 - 30 VDC PNP/NPN



TD 800-006

Declaration of Conformity

The designating company

Alfa Laval

Company Name

Albuen 31, DK-6000 Kolding, Denmark

Address

+45 79 32 22 00

Phone No.

hereby declare that

Top Unit for Valve Control & Indication

Denomination

ThinkTop® Digital VDC

Type

Year

is in conformity with the following directives with amendments:

- Low Voltage Directive 73/23/EEC
- EMC Directive 89/336/EEC

Vice President, R & D

Title

Bjarne Søndergaard

Name

Alfa Laval

Company

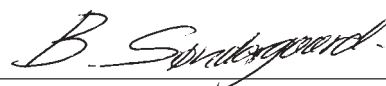

Signature

Designation



The information contained herein is correct at the time of issue but may be subject to change without prior notice.

1. Safety	6
1.1 Important information	6
1.2 Warning signs	6
1.3 Safety precautions	6
2. General information	7
2.1 Digital in general	7
3. Technical specifications	8
3.1 <i>ThinkTop</i> [®] , PLC 8-30 VDC interface	8
4. Installation	12
4.1 Installation on air actuators	12
4.2 Installation on Series 700 valves	15
4.3 Air connections	16
4.4 Electrical connection, internal	17
4.5 Example of connecting power supplies	17
5. Setup diagram	18
5.1 <i>ThinkTop</i> [®] setup utilising IR keypad	18
5.2 <i>ThinkTop</i> [®] setup utilising local 'I' and 'II' keys	20
6. Fault finding	22
6.1 Fault finding and LEDs	22
7. Maintenance	24
7.1 Dismantling of <i>ThinkTop</i> [®]	24
7.2 Assembly of <i>ThinkTop</i> [®]	26
7.3 Dismantling and assembly of Series 700 Valves	28
8. Parts list	30
8.1 <i>ThinkTop</i> [®] Digital 8-30 VDC PNP/NPN	30
8.2 <i>ThinkTop</i> [®] Series 700 valves	32

1.1 Important information

1.2 Warning signs

1.3 Safety precautions

Unsafe practices and other important information are emphasized in this manual.

Warnings are emphasized by means of special signs.

All warnings in the manual are summarized on this page.

Pay special attention to the instructions below so that severe personal injury or damage to the top unit are avoided.

Always read the manual before using the top unit!

WARNING!

Indicates that special procedures **must** be followed to avoid severe personal injury.

CAUTION!

Indicates that special procedures **must** be followed to avoid damage to the *ThinkTop*[®].

NOTE!

Indicates important information to simplify or clarify practices.

General warning:



Dangerous electrical voltage:



Caustic agents:



Installation

- **Always** observe the technical specifications (see chapter 3).
- **Never** install the *ThinkTop*[®] before valve or relay is in a safe position.
- If welding close to the *ThinkTop*[®]: **Always** earth close to the welding area.
- Disconnect the *ThinkTop*[®].
- **Always** have the *ThinkTop*[®] electrically connected by authorized personnel.



Maintenance

- **Always** read the technical specifications thoroughly (see chapter 3).
- **Always** fit the seals between valve and *ThinkTop*[®] correctly.
- **Never** service the *ThinkTop*[®] before valve or relay is in a safe position.
- **Never** service the *ThinkTop*[®] with valve/actuator under pressure.
- **Never** clean the *ThinkTop*[®] with high pressure cleaning equipment.
- **Never** use cleaning agents when cleaning the *ThinkTop*[®]. Check with cleaning agent supplier.



The **ThinkTop**[®] is designed to ensure optimum valve control in conjunction with Alfa Laval valves and it is compatible with most PLC systems (Programmable Logic Controllers maker with PNP/NPN interface).

The **ThinkTop**[®] can be equipped with 0-3 solenoid valves. The solenoids are electrically controlled by the Digital PLC and when activated the compressed air is activating the air actuator. All solenoids have built-in throttle function on both air inlet and outlet which means that it is possible to control the opening and closing time of the air actuator. The solenoids are also equipped with a manual hold override.

Visual LED lights are constantly indicating the status of the unit: Valve positions, solenoid activated, setup and local fault indication etc.

The **ThinkTop**[®] is characterized by a simple and modular design. It is exchangeable and is prepared for upgrading.

3.1.1 “No Touch” sensor system

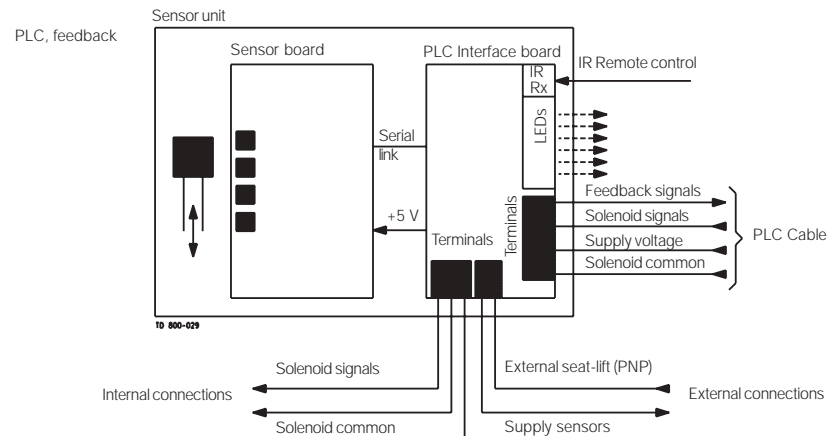

Type: Alfa Laval “No Touch” System

For wire connections: See section 4.4 “Electrical connection, internal”.

Features

- Tolerance programmes.
- Self adjustment programme (SRC/ARC valves only).
- Built-in maintenance monitor.
- Setup by internal pushbuttons or remote control (IR Keypad).
- Setup and local fault supervision.
- Setup saved at power shutdown.
- Visual LED Indicator lights.

Sensor System

Unique “No Touch” sensor system without any mechanical sensor adjustments. A magnet is mounted on the valve stem and the magnetic field (axial) is detected by sensor chips inside the sensor unit. The measuring angle from each chip is used to locate the current position of the valve stem with an accuracy of ± 0.1 mm. Note that the distance to the magnet can be $5 \text{ mm} \pm 3 \text{ mm}$.

Feedback signals

The sensor system can be used for 4 feedback signals + 1 status signal = 5 digital PNP/NPN feedback signals. Selection of PNP or NPN is done by a jumper. Two of the feedback signals can be used for external sensors if necessary.

The status signal is used for detection of the following three conditions:

- A set-up is in progress.
- Internal error.
- Maintenance is required (based on time and/or the self adjustment programme).

Tolerance programme:

Individual according to valve types.

- Type 1: SRC/ARC and Series 700 valves.
- Type 2: LKB (LKLA-T).
- Type 3: *Unique*, SMP-SC Spillage-Free, SRC-PV and AMP.
- Type 4: SMP-SC, SMP-TO, SMP-BC, SMP-BCA and SBV.
- Type 0: (Preset) All Parameters Set To Default (also valid for MH Koltek valve and SMP-EC (seat-lift indication not possible for SMP-EC)).

Preset and reset values: Tolerance programme No. 0 (± 5 mm) and all functions are disabled.

NOTE! Important to select the right tolerance programme.

Self Adjustment (SRC/ARC valves only)

The self adjustment feature is an exceptional aspect of the *ThinkTop*[®] design. A programme can be activated to allow an adjustment of the tolerance band if the seals in the valve are being compressed or are worn. When the tolerance band of the unit has been adjusted 0.3 mm, an alert warning will appear in the form of a status signal and a flashing maintenance LED. After 0.5 mm adjustment an alarm warning appears: Loss of feedback signal, status signal and steady maintenance light indicating a minimum of seal left requiring a replacement of the seal.

Built-in Maintenance Monitor

The unit can be preset to indicate when the time for maintenance of the valve has been reached. A status signal and flashing maintenance LED can be programmed to return after 3, 6, 9 or 12 months or more.

3.1.2 Technical specifications sensor system

Sensor accuracy: $\pm 0,1$ mm.
 Distance to magnet: 5 ± 3 mm.
 Stroke length: 0.1 - 80 mm.
 Electrical connection: Direct cable gland entry (hard wired)
 PG11 ($\varnothing 4 - \varnothing 10$ mm).

Terminals

The terminal row of the sensor unit is equipped with screw terminals for both internal as well as external cables and wires. The terminals are suitable for wires up to 0.75 mm² (AWG 19).

Power Supply, must meet the requirements of EN 61131-2.

The *ThinkTop*[®] is designed to be a part of the PLC's Input/Output (I/O) system. It should be supplied from the same protected power supply as the other I/O devices. The I/O power supply should not be used for other kinds of loads.

The unit is reverse polarity and short circuit protected.

Supply voltage:	8 - 30 VDC.
Supply voltage nominal:	24 VDC (+20%, -15%) - pr. EN 61131-2.
Max ripple:	5% of nominal supply voltage.
Supply voltage absolute max.:	30 VDC.
Supply voltage absolute min.:	8 VDC.
Supply current*):	Max. 45 mA (for sensor unit alone) (excluding current to the solenoids, external proximity switches and the PLC input current).

*) The initial current during power-on is higher. The actual shape of the current pulse depends on the power supply used. Typical values are 150 mA RMS during 13 ms (regulated PS) to 360 mA RMS during 8 ms (unregulated PS).

The fulfilling of the UL requirements in UL508 requires that the unit is supplied by an isolating source complying with the requirements for class 2 power units (UL1310) or class 2 and 3 transformers (UL1585).

Feedback signals

Output signals from the sensor unit to the connected PLC.

Nominal voltage:	Must match the selected type of <i>ThinkTop</i> [®] .
Load current:	Typically 50 mA, max. 100 mA .
Voltage drop:	Typically 3 V at 50 mA.

External sensors

The external sensors are used for seat-lift supervision when seat-lift can not be internally detected. The sensors get their supply voltage from the terminal row. The output signals from the sensors are connected to two inputs on the terminal row on the internal sensor unit. If the actual setup is set for internal seat-lift, the corresponding external signal is not used, otherwise the external signal logically controls the corresponding feedback to the PLC (Programmable Logic Controller).

Supply voltage:	Must match the selected type of <i>ThinkTop</i> [®] .
Supply current:	Max. 15 mA per sensor.
Type of sensor:	DC, Only 3-wire sensor PNP.
Sensor cable length:	Max. 3 m.

Polarity

PNP (sourcing) or NPN (sinking) function is selected with a jumper in term. 12 and 13.

Jumper present = PNP. If changing to NPN remove the jumper and make a power recycle. A power recycle is always required when changing this function.

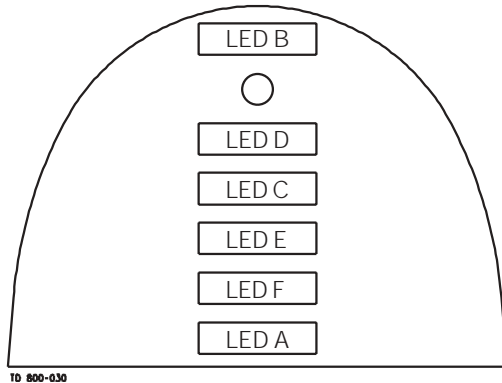
ThinkTop® Visual Indications**LED Indications**

"Open valve"	(Yellow)
IR-Receiver	
"Setup/Internal fault"	(Red)
"Seat-lift 1/2"	(Yellow)
"Solenoid valves"	(Green)
"Maintenance"	(Orange)
"Closed valve"	(Yellow)

Feedback signals:

Signal:	"Closed Valve"	Terminal 1	(Feedback #1)
Signal:	"Open Valve"	Terminal 2	(Feedback #2)
Signal:	"Seat-lift 1"	Terminal 3	(Feedback #3)
Signal:	"Seat-lift 2"	Terminal 4	(Feedback #4)
Signal:	"Status"	Terminal 5	(Feedback #5)

For wire connections: See chapter 4 "Electrical connection, internal".

Note: If the programmer wishes to detect a physical closed valve position in an "Open Valve" sensor position, then there is no longer any consistence between the sensor valve detection position and the visual indications of the *ThinkTop*®.

Status signal:

The status signal (Feedback # 5) is used for four purposes:

- To indicate that setup is in progress + (LED D).
- To indicate an error condition + (LED D). (Flashing LED = software error), (steady LED = hardware error).
- To indicate maintenance due to the self adjustment programme + (LED F).
- To indicate that the time for maintenance has been reached + (LED F).

3.1.3 Technical specifications solenoid valves**Solenoid signals**

Three output signals (with one common) from the terminal row are used for activation of the solenoids. Depending on the PLC used, the common could be either positive or negative for DC voltage. The signals are galvanically isolated from the sensor circuits.

Internal connections

Terminals for connection of the solenoids mounted internally in the control head. The number of solenoids actually mounted in the control head could be 0 - 3. The signals are taken directly from the terminal row.

Technical specifications	
Up to 3 solenoid valves in each unit.	
Type	3/2 or 5/2 valve (only possible with one 5/2 valve).
Air supply	300-900 kPa (3-9 bar).
Filtered air, max. particles or dirt	0.01 mm.
Max. flow	180 l/min.
Max. oil content	1.0 ppm.
Max. water content	0.0075 kg/kg air.
Throughput	ø2.5 mm.
Air restriction (throttle function) air inlet/outlet.	
Manual hold override.	
External air tube connection	ø6 mm or 1/4" (specify when ordering).
Nominal voltage	24 VDC.
Nominal power	1.0 W.
Silencer/filter *)	Connection possible via ø6 mm or 1/4".
Materials	
Plastic parts	Nylon PA12.
Steel parts	Stainless steel AISI 304 and 316.
Seals	Nitrile (NBR), EPDM rubber for SMP-EC activator stem.
*) Note! Filter recommended in tropical regions.	

3.1.4 Micro environment demand specifications

Temperature		
Working:	-20°C to +85°C	IEC 68-2-1/2
Storage:	-40°C to +85°C	IEC 68-2-1/2
Temperature change:	-25°C to +70°C	IEC 68-2-14
Vibration	10-55 Hz, 0.7 mm 55-500 Hz, 10g 3 x 30 min, 1 octave/min	IEC 68-2-6
Drop test		IEC 68-2-32
Humidity		
Constant humidity:	+40°C, 21 days, 93% R.H.	IEC 68-2-3
Cyclic humidity:	+25°C/+55°C 12 cycles	IEC 68-2-30
(working)	93% R.H.	
Protection class	IP67	IEC 529
Input treshold		
Voltage/current:	Type 1 input requirements	EN 61131-2
Solenoid signals		
Isolation voltage	(1000 + 2 x 117) VAC rms/1 min	EN 61131-2
EMC Directive	89/336/EEC	EN 50081-1, EN 50082-2
UL Approval	8-30 VAC/VDC, Class 2 input, 45 mA max. output	UL 508-E203255

Step 1

- **Always** read the technical specifications thoroughly (see chapter 3).
- **Always** have the *ThinkTop*[®] electrically connected by authorized personnel.
- **Always** install the *ThinkTop*[®] before valve or relay is in a safe position.

Step 2

1. Fit the air fittings on actuator if not mounted.
2. Fit the activator stem (magnet) and tighten **carefully** with a spanner.

NOTE!

The *ThinkTop*[®] for the SMP-EC valve has a longer activator stem going through the shell. Remember O-ring.

SRC/ARC only

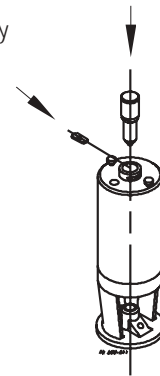
**Step 3**

1. Place the *ThinkTop*[®] on top of the actuator.
2. Make sure X-ring is mounted.

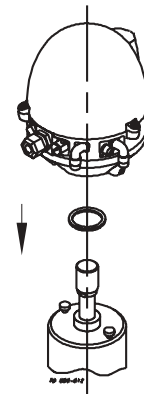
**Step 4**

1. Ensure that the unit is correctly mounted by pressing down on top of the *ThinkTop*[®].
2. Tighten the two Allen screws **carefully**.
3. Turn the actuator to have LEDs in a front view.

NOTE!

After a relevant period of time after installation (e.g. two weeks) it is recommended to check that all connections are properly tightened.

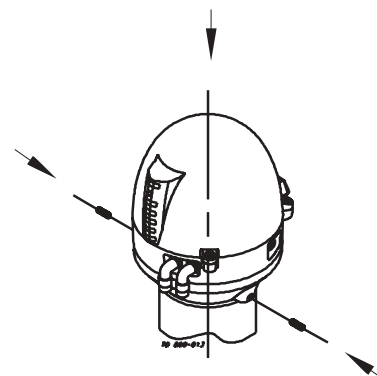

Step 5

Fit the $\varnothing 6$ mm (1/4") air tubes to *ThinkTop*[®] (see drawing "Air connections" later in this chapter).

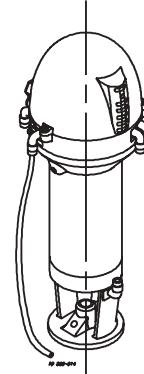
**Step 6**

Fit the air tubes to the actuator (see drawing "Air connections" later in this chapter).

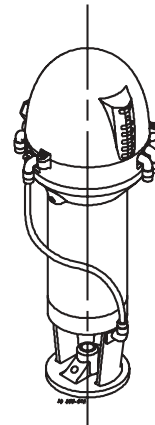
**Step 7**

Untighten the three screws and pull off cover of *ThinkTop*[®].

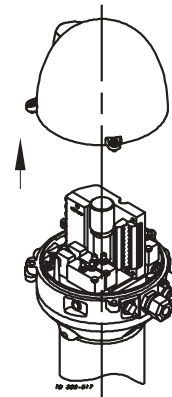
**Step 8**

1. Install cable (if not present) through the cable gland.
2. Connect the *ThinkTop*[®] electrically (see section 4.4 "Electrical connection, internal").

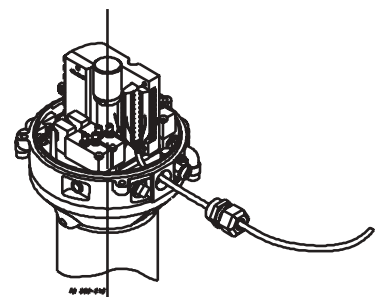

Step 9

Make sure the cable gland is completely tightened.

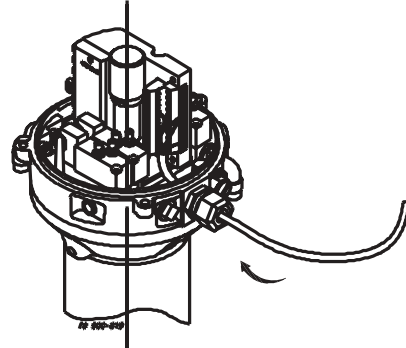
**Step 10**

Set up the *ThinkTop*[®] (see chapter 5).

NOTE!

The unit can be set up with the cover installed by using the IR keypad. To energize the valve, use a separate air tube or be in radio contact with the control room.

Step 1

1. Remove the cover by loosening the three cross recess screws.
2. Separate the adapter from the base by loosening the three recess screws on top of the base.

Installation on air actuators:

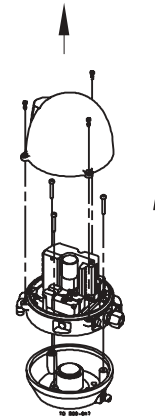

Step 2

1. Fit air fittings on actuator.
2. Position packing retainer in recess on actuator top.
3. Fit counter nut and indicator (magnet) on actuator rod. Engage approx. 1/4" thread. Tighten counter nut and indicator with two wrenches.

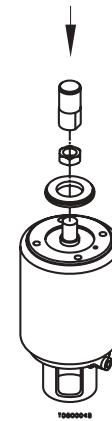

Step 3

1. Place the two O-rings in the grooves in the bottom of the adapter. Then place the adapter on the actuator top. The small O-ring must be positioned over the air hole on the actuator.
2. Fasten the adapter with the four 5/16" Allen screws.



Step 4

Mount the base on the adapter in the position needed (can be rotated 120° in both directions). Note that one of the screw towers on the adapter has a guide recess (see ★ on drawing).

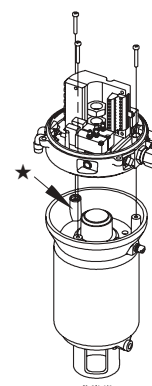

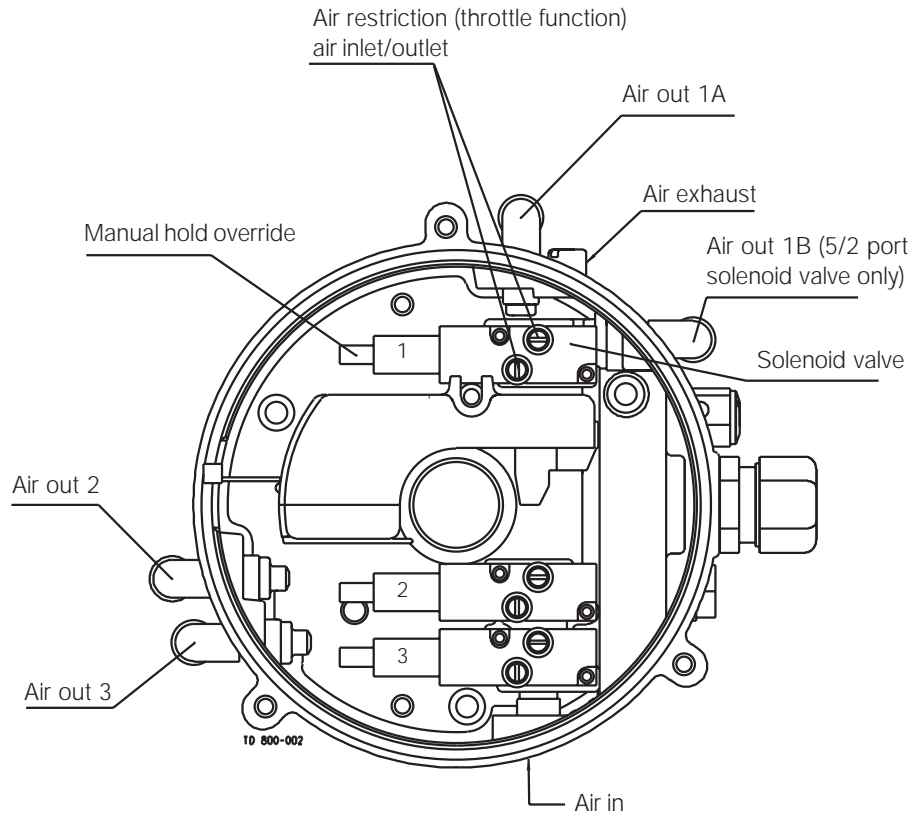

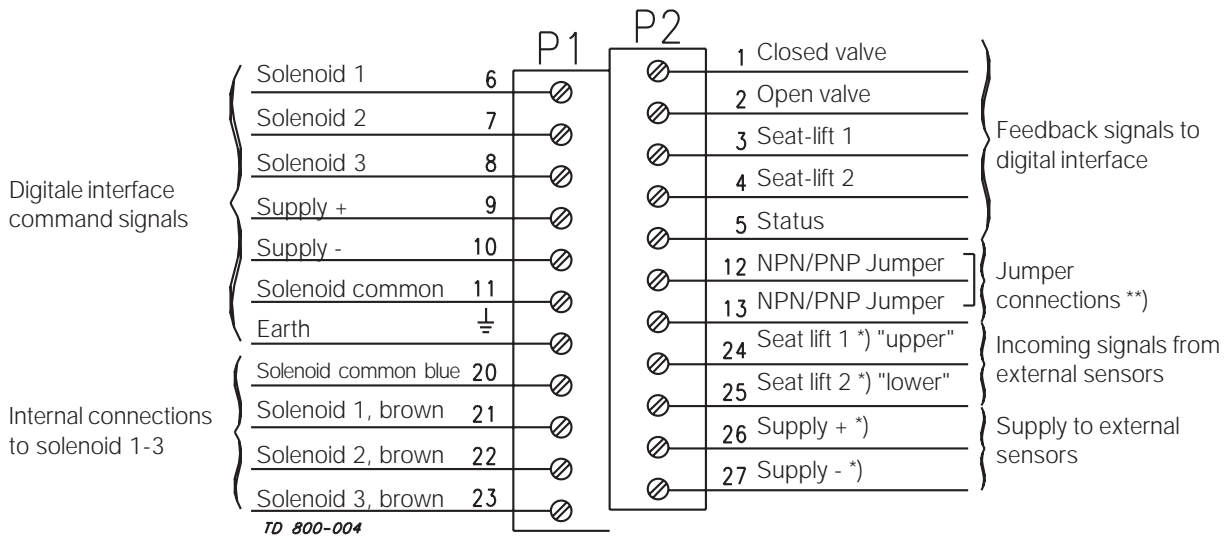

***) Note!**

- Terminals 24, 25, 26 and 27 can be used for external seat-lift sensors as well as for any digital input. Always use an external PNP sensor.
- Two external signals can be connected, they are associated with feedback signal 3 (seat-lift 1) and 4 (seat-lift 2). External sensor must always be a 8-30 VDC PNP 3 wire sensor. Connect (-) common on terminal 27, and (+) common on terminal 26. The signals from the external sensors are associated as follows: sensor signal on terminal 24 (seat-lift 1) associated with feedback 3 (seat-lift 1), and sensor signal on terminal 25 (seat-lift 2) associated with feedback 4 (seat-lift 2).

****) Note!**

Jumper present = PNP. If changing the function a power recycle is necessary. The selection NPN/PNP is done by the jumper.

Note! Remember to isolate wires that are not in use.

One power supply for sensor system and solenoid valves:

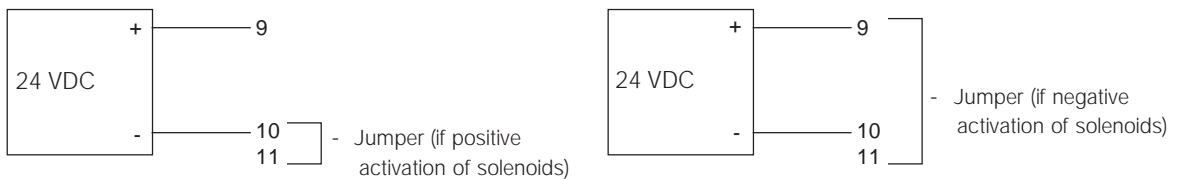

Two power supplies, one for sensor system and one for the solenoid valves:

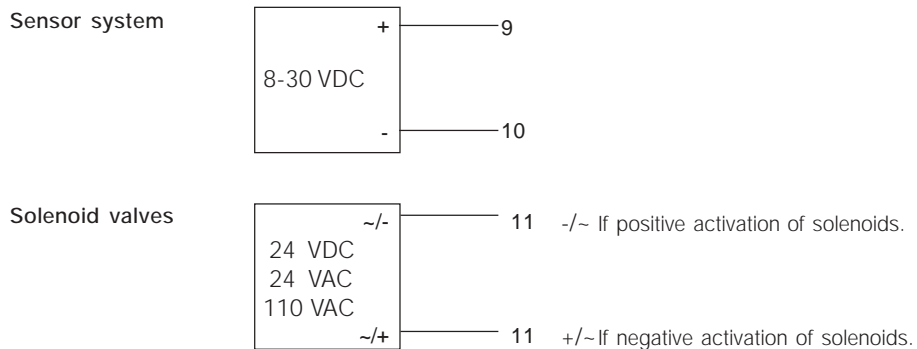

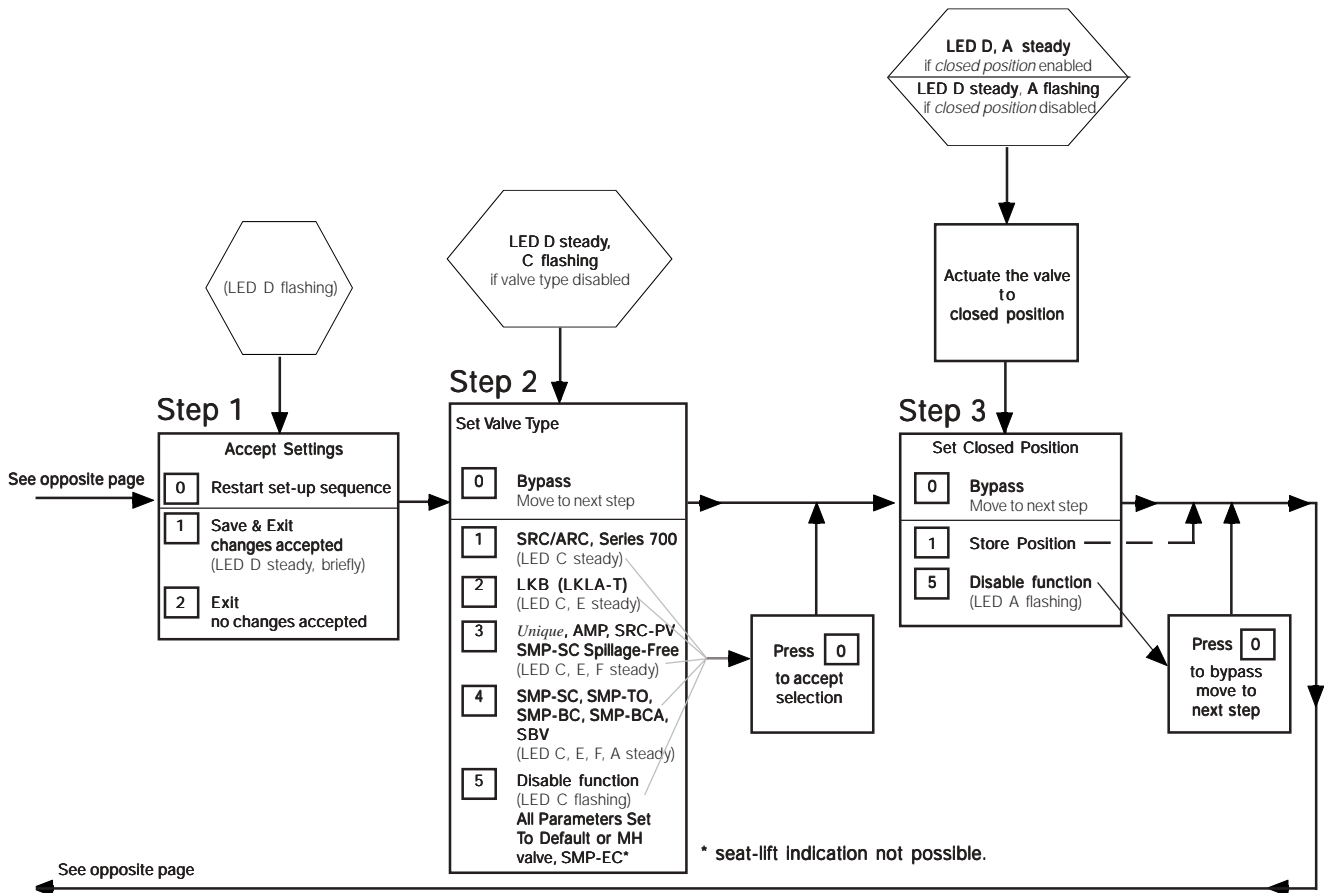

Note! Remote distance keypad = ThinkTop® 0-300 mm.

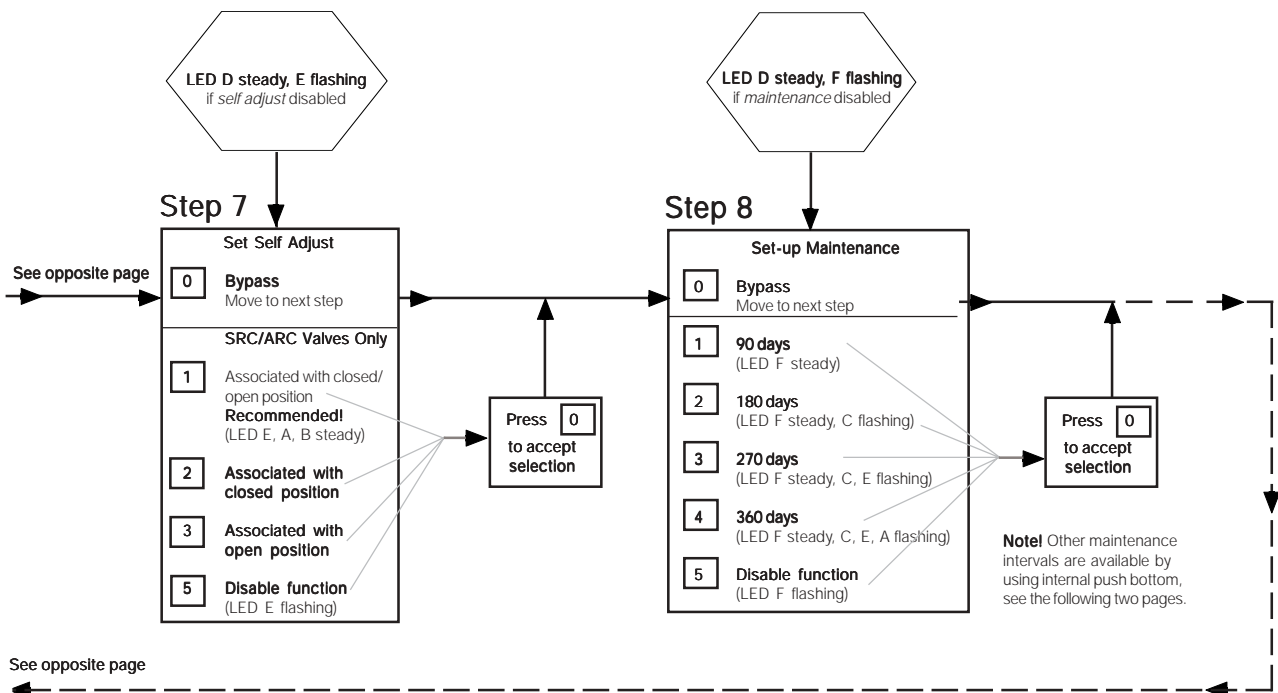

- Notes:**
- I - Scroll across, no change
 - - Notes Requires Key Function
 - - - - Notes Automatic Progress as Indicated

- General:**
1. Flashing IND means no value set. Steady IND means value set as shown.
 2. Default is: Step 2, Type 0 (+/- 5 mm)
Step 3-8 disabled
 3. Lamp Status Shown in []

ThinkTop® Visual Indications

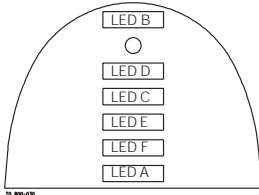

LED Indications

"Open valve"	(Yellow)
IR-Receiver	
"Setup/Internal fault"	(Red)
"Seat-lift 1/2"	(Yellow)
"Solenoid valves"	(Green)
"Maintenance"	(Orange)
"Closed valve"	(Yellow)

4. [D] IND active during set-up.
 - Flashing in step 1,
 - Steady in all other steps.
 or during operations, error condition
 - Steady showing hardware fault
 - Flashing showing software fault
5. Timeout: A 60 second time-out is started as soon as any button(s) are released. If no button is pressed during the time-out time, go to normal condition (cancel & exit).
6. SRC/ARC valves: Self-adjust (step 7) must be activated. If you choose NOT to use the self-adjustment programme, Alfa Laval recommends to use the valve type 4 (step 2), instead of type 1 (bigger tolerances).

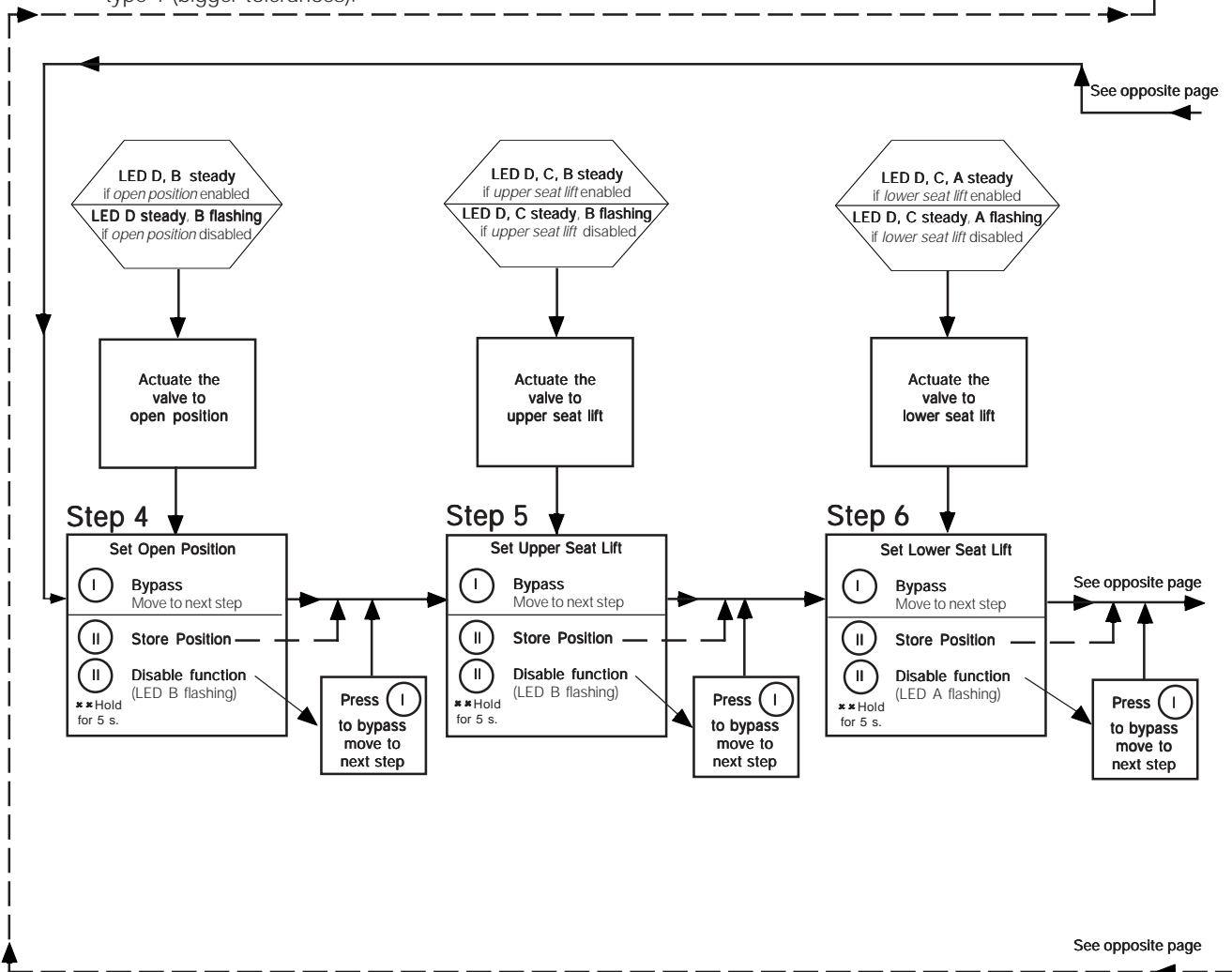
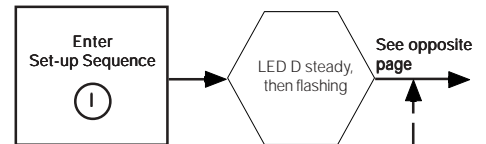

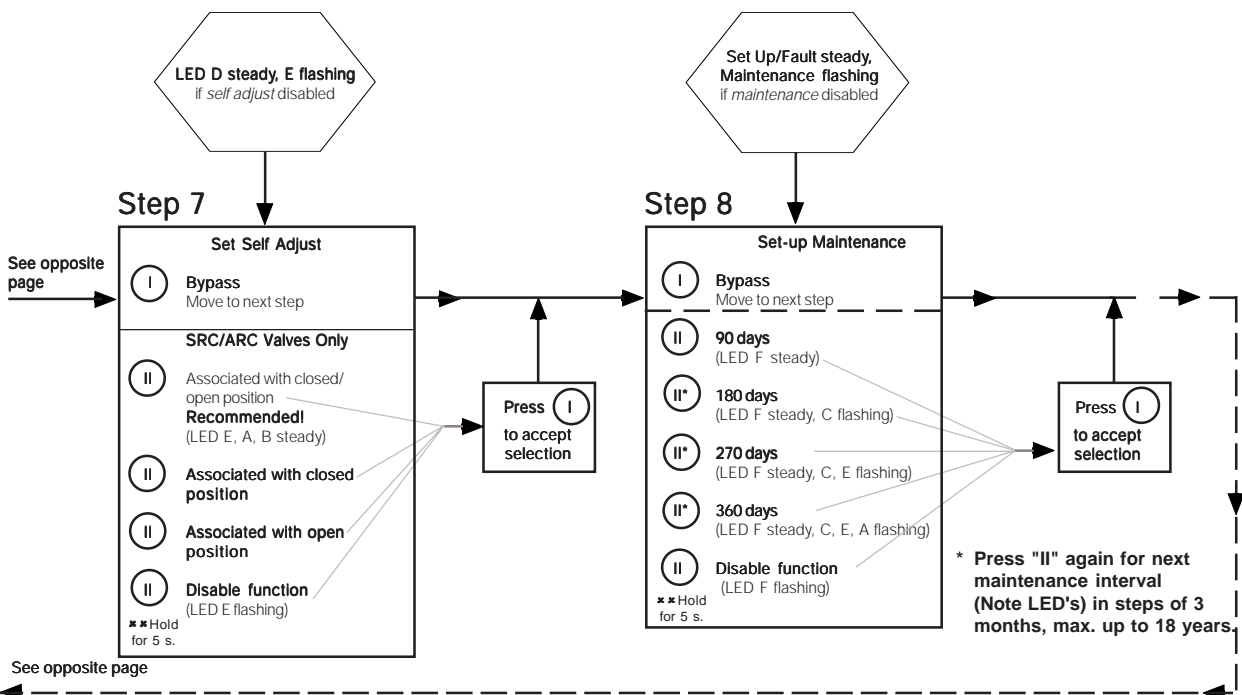
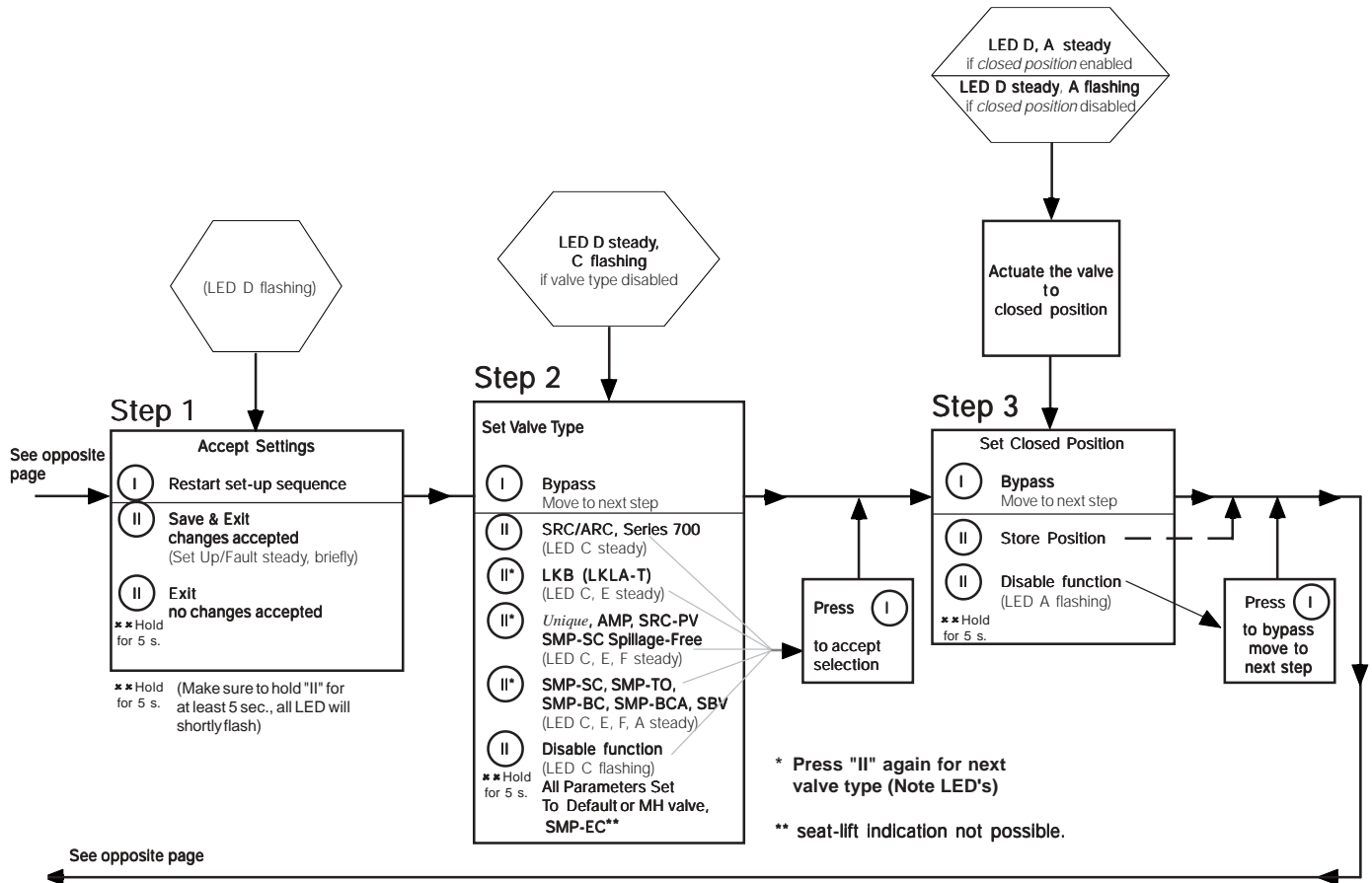

Below is stated the meaning of the LEDs' indications for fault finding in connection with the operation of the *ThinkTop*[®].

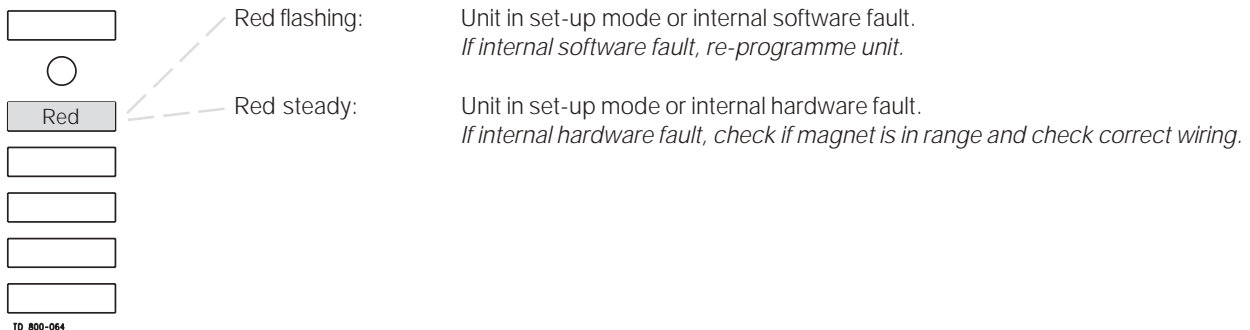

Red flashing: Unit in set-up mode or internal software fault.

If internal software fault, re-programme unit.

Red steady: Unit in set-up mode or internal hardware fault.

If internal hardware fault, check if magnet is in range and check correct wiring.

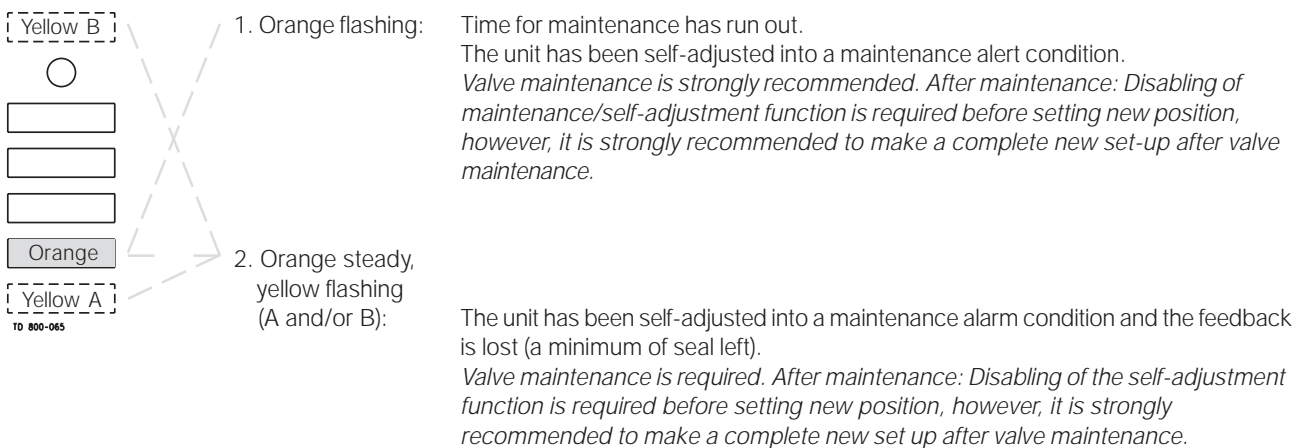

1. Orange flashing: Time for maintenance has run out.

The unit has been self-adjusted into a maintenance alert condition.

Valve maintenance is strongly recommended. After maintenance: Disabling of maintenance/self-adjustment function is required before setting new position, however, it is strongly recommended to make a complete new set-up after valve maintenance.

2. Orange steady, yellow flashing (A and/or B):

The unit has been self-adjusted into a maintenance alarm condition and the feedback is lost (a minimum of seal left).

Valve maintenance is required. After maintenance: Disabling of the self-adjustment function is required before setting new position, however, it is strongly recommended to make a complete new set up after valve maintenance.

NOTE!

The maintenance indicator lighting up, and an open or closed light flashing....

= Note the following:

- Self-adjustment programme is only valid for **SRC/ARC** valves, **do not use the programme for other valve types**.
- Use tolerance/valve type 1.
- In conjunction with valve type change-over; 21, 22, 31 and 32, the open position must be defined as the upper sensor position (when the magnet is in the highest position).
- A loose top, magnet holder or sensor system can also generate the alert/ alarm condition.
- Removing a *ThinkTop*[®] with self-adjust activated, will immediately generate an alarm condition! If the *ThinkTop*[®] has to be removed, not because of a valve maintenance issue, but for some other reasons, and you want to store the already adjusted data - disable the self-adjust function before removing the *ThinkTop*[®] and enable it again once the *ThinkTop*[®] is back on the actuator.
- After valve maintenance a disabling of the self-adjustment function is required before setting a new position, however, it is strongly recommended to make a complete new set-up (disable all functions in step 2 valve type - and make a complete new set-up).

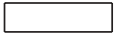

TD 800-064

Yellow steady: Position A (closed valve).

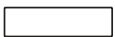
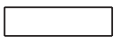
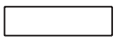
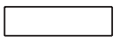

TD 800-064

Yellow steady: Position B (open valve).

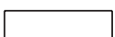
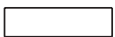

TD 800-064

Yellow steady: Position C (Seat lift 1-2 or external sensors).

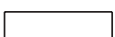
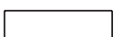
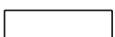

TD 800-064

Green steady: Solenoid valves activated.

Note! During set-up LED lights have different functions.

*Study the instructions carefully.
Handle scrap correctly.
Always keep spare X-rings in stock.*

Step 1

1. Remove the *ThinkTop*® from the actuator.
2. Pull out X-ring and replace it.

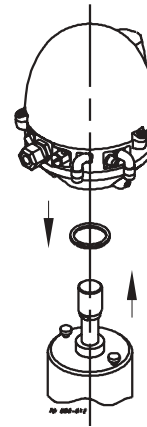
**Step 2**

1. Untighten the three screws.
2. Pull off cover of *ThinkTop*®.

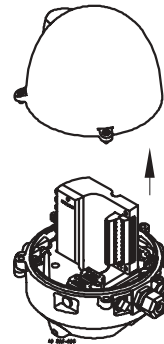
**Step 3**

1. Untighten screws.
2. Remove solenoid valves (up to three) and replace them with new ones.

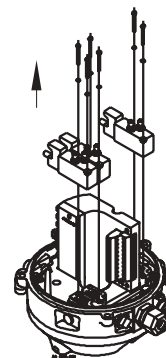
**Step 4**

1. To dismantle the adapter (the lower part of the *ThinkTop*®) from base (the middle part), unscrew the three screws.
2. Turn the lower part a little clockwise and pull.
3. Replace adapter if necessary.

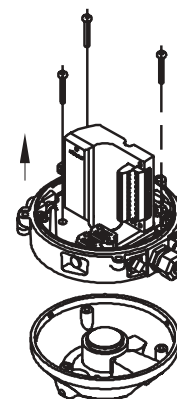

Note:
Turn banjo
connection!

*Study the instructions carefully.
Handle scrap correctly.
Always keep spare X-rings in stock.*

Step 5

To remove the sensor unit untighten screw and pull out the sensor unit.

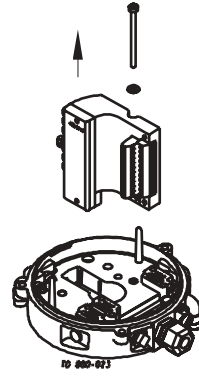

*Study the instructions carefully.
Handle scrap correctly.
Always keep spare X-rings in stock.*

Step 1

Place sensor unit in base and tighten screw (torque: 1 Nm).

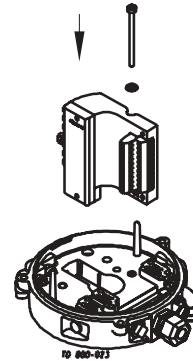

Step 2

Assemble base with adapter by turning adapter slightly anticlockwise and tighten the three screws (1.9 Nm).

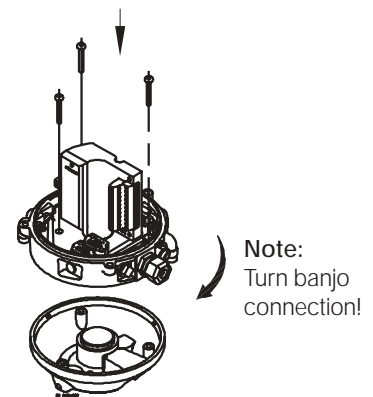

Step 3

1. Replace solenoid valves (up to three) with new ones.
2. Tighten screws (0.2 Nm).

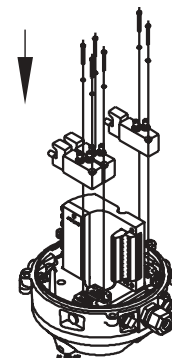

Step 4

Replace cover of *ThinkTop*[®] and tighten the three screws (0.6 Nm).

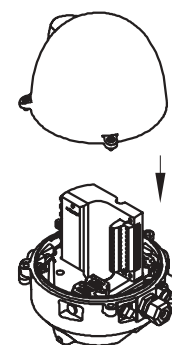

Study the instructions carefully.
Handle scrap correctly.
Always keep spare X-rings in stock.

Step 5

1. Replace X-ring.
2. Mount *ThinkTop*® on actuator.

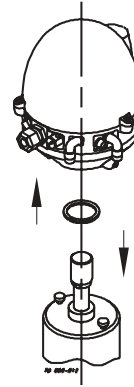

*Study the instructions carefully.
Handle scrap correctly.
Always keep spare X-rings in stock.*

Step 1

1. Remove the cover by loosening the three cross recess screws.
2. Separate the adapter from the base by loosening the three recess screws on top of the base.

Installation on air actuators:

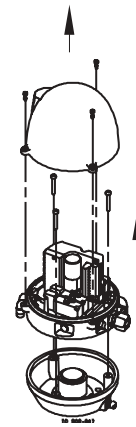
**Step 2**

1. Fit air fittings on actuator.
2. Position packing retainer in recess on actuator top.
3. Fit counter nut and indicator (magnet) on actuator rod. Engage approx. 1/4 " thread. Tighten counter nut and indicator with two wrenches.

**Step 3**

1. Place the two O-rings in the grooves in the bottom of the adapter. Then place the adapter on the actuator top. The small O-ring must be positioned over the air hole on the actuator.
2. Fasten the adapter with the four 5/16" Allen screws.

**Step 4**

Mount the base on the adapter in the position needed (can be rotated 120° in both directions). Note that one of the screw towers on the adapter has a guide recess (see ★ on drawing).

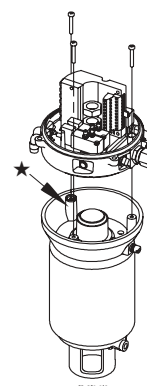

The drawing and the parts list include all items.

Parts List

Pos.	Denomination
1a	Shell
1b	Shell
2	O-ring, NBR
3	Screw
4	Washer
5	Sensor unit
6	Solenoid valve
7	PT screw
8	Base
9	O-ring, NBR
10	Air fittings
11	Blow-off valve
12	Thread plug, PG7
13	Cable gland, PG11 4-10 mm
14	Pressure control valve
15	Adapter
16	O-ring
17	O-ring
18	Allen screw
19	Special X-ring
20a	Indication pin
20b	Indication pin
21	O-ring, EPDM
22	5 m. flying PVC cable (12 x 0.5 mm ²)
24	Air fitting incl. O-ring

Spare Parts

Denomination	Item number
Sensor unit Digital 8-30 VDC PNP/NPN	9612-5627-01
Solenoid valve 3/2, 24 VDC	9611-99-3324
Solenoid valve 5/2, 24 VDC	9611-99-3327
Solenoid valve 3/2, 24 VAC	9611-99-3325
Solenoid valve 3/2, 110 VAC	9611-99-3326
Solenoid valve 5/2, 24 VAC	9611-99-3328
Solenoid valve 5/2, 110 VAC	9611-99-3329
Air fitting incl. O-ring, Ø6 mm	9611-99-3404
Air fitting incl. O-ring, 1/4"	9611-99-3434

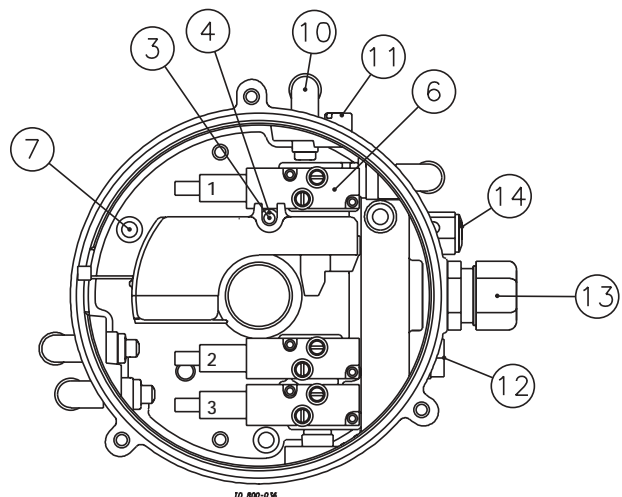
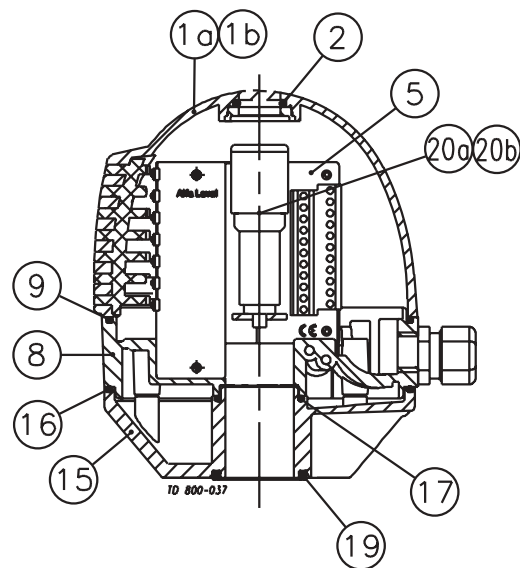
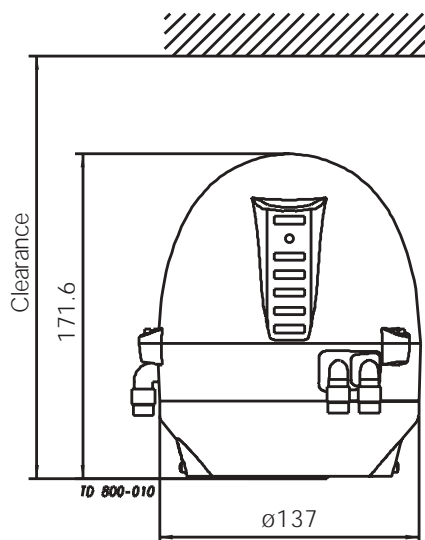

Note! This is the basic design.

The clearance should be approximately:

- ø 225 x 250 (SRC NC, SMP-SC/-BC/-TO, Unique, Koltek MH, SBV, AMP)
- ø 225 x 320 (SRC NO)
- ø 225 x 300 (LKB (LKLA-T))

This page shows an exploded drawing of the ThinkTop®.

The drawing includes all items of the top unit.

Exploded Drawing

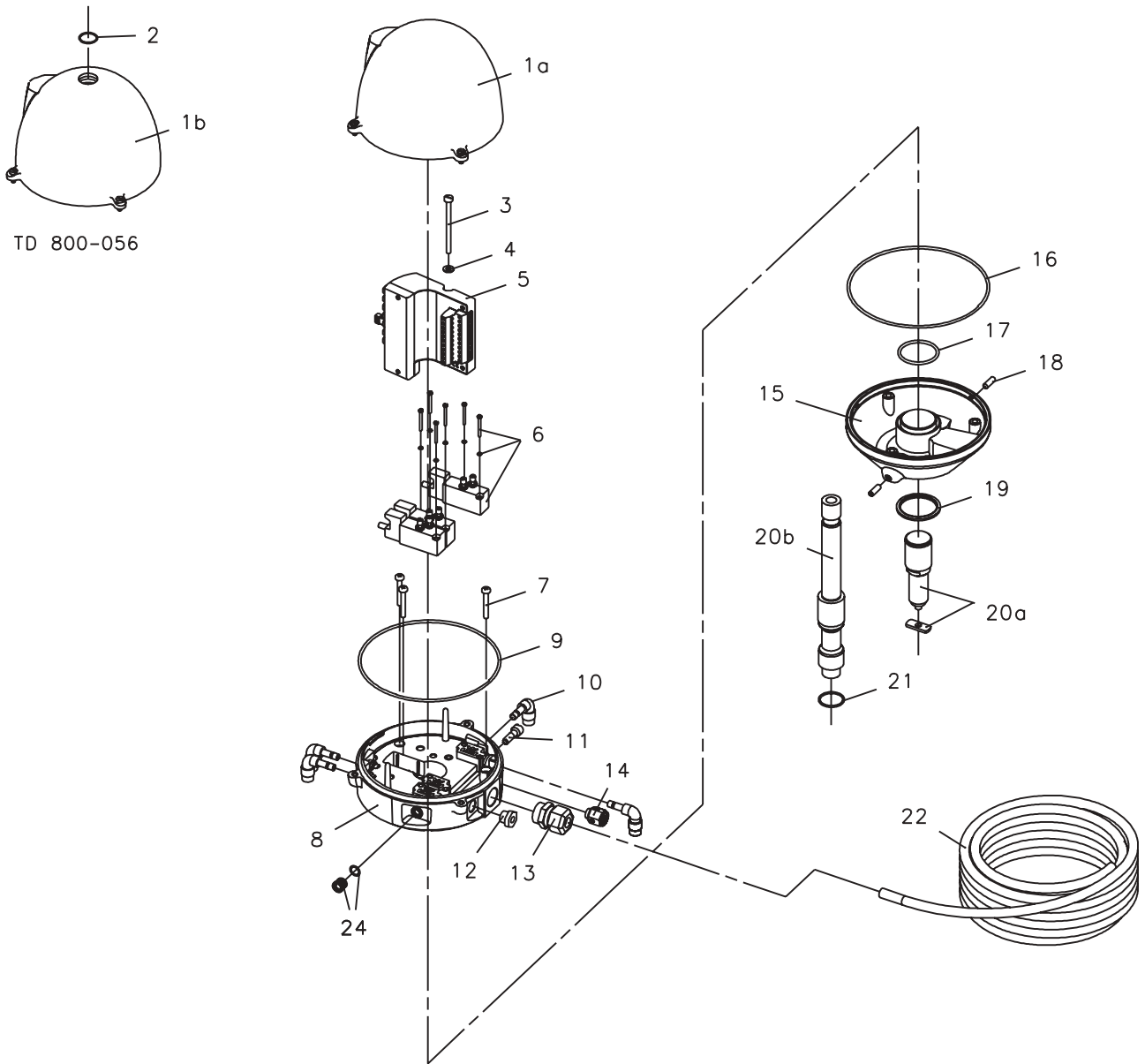

The drawing and the parts list include all items.

Parts List

Pos.	Denomination
1	Shell
3	Screw
4	Washer
5	Sensor unit
6	Solenoid valve
7	PT screw
8	Base
9	O-ring, NBR
10	Air fittings
11	Blow-off valve
12	Thread plug, PG7
13	Cable gland, PG11 4-10 mm
14	Pressure control valve
15	Adapter
16	O-ring
17	O-ring
18	Screw
19	Retainer
20	O-ring
21	O-ring, EPDM
22	Indicator pin
23	Nut
24	5 m. flying PVC cable (12 x 0.5 mm ²)
26	Air fitting incl. O-ring

Spare Parts

Denomination	1/4" Air connec.
Sensor unit Digital 8-30 VDC PNP/NPN	9612-5627-01
Solenoid valve 3/2, 24 VDC	9611-99-3324
Solenoid valve 5/2, 24 VDC	9611-99-3327
Solenoid valve 3/2, 24 VAC	9611-99-3325
Solenoid valve 3/2, 110 VAC	9611-99-3326
Solenoid valve 5/2, 24 VAC	9611-99-3328
Solenoid valve 5/2, 110 VAC	9611-99-3329
Air fitting incl. O-ring, 1/4"	9611-99-3434

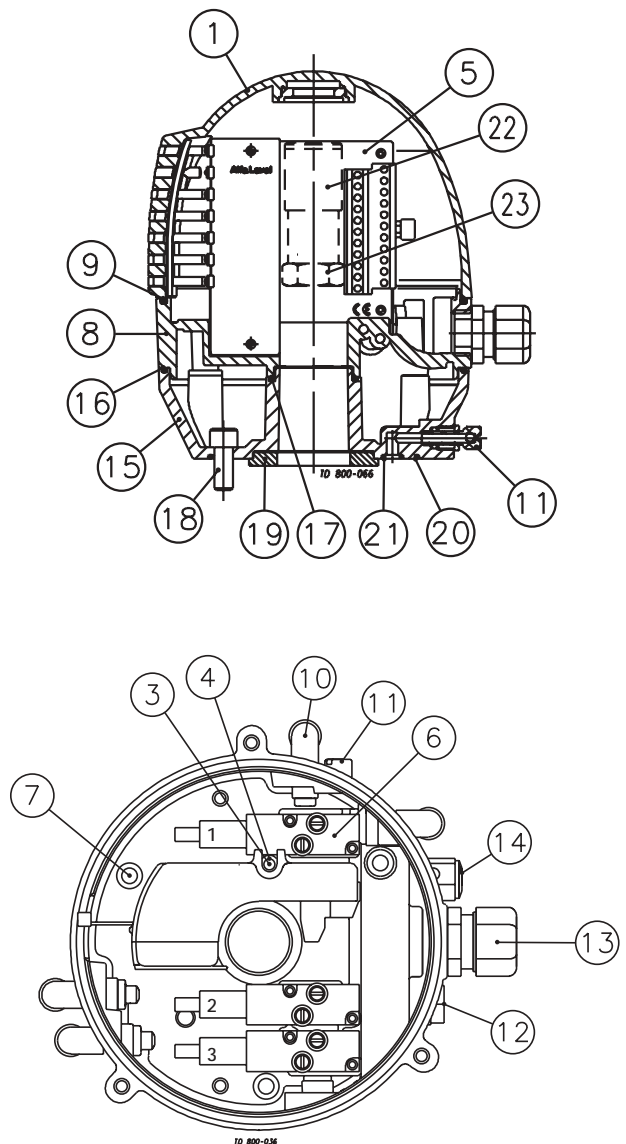
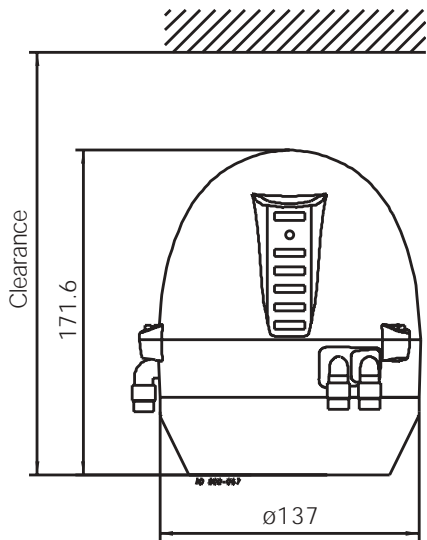

Note! This is the basic design.

The clearance should be approximately:

- ø 225 x 250 (SRC NC, SMP-SC/-BC/-TO, Unique, Koltek MH, SBV, AMP)
- ø 225 x 320 (SRC NO)
- ø 225 x 300 (LKB (LKLA-T))

This page shows an exploded drawing of the ThinkTop®.

The drawing includes all items of the top unit.

Exploded Drawing

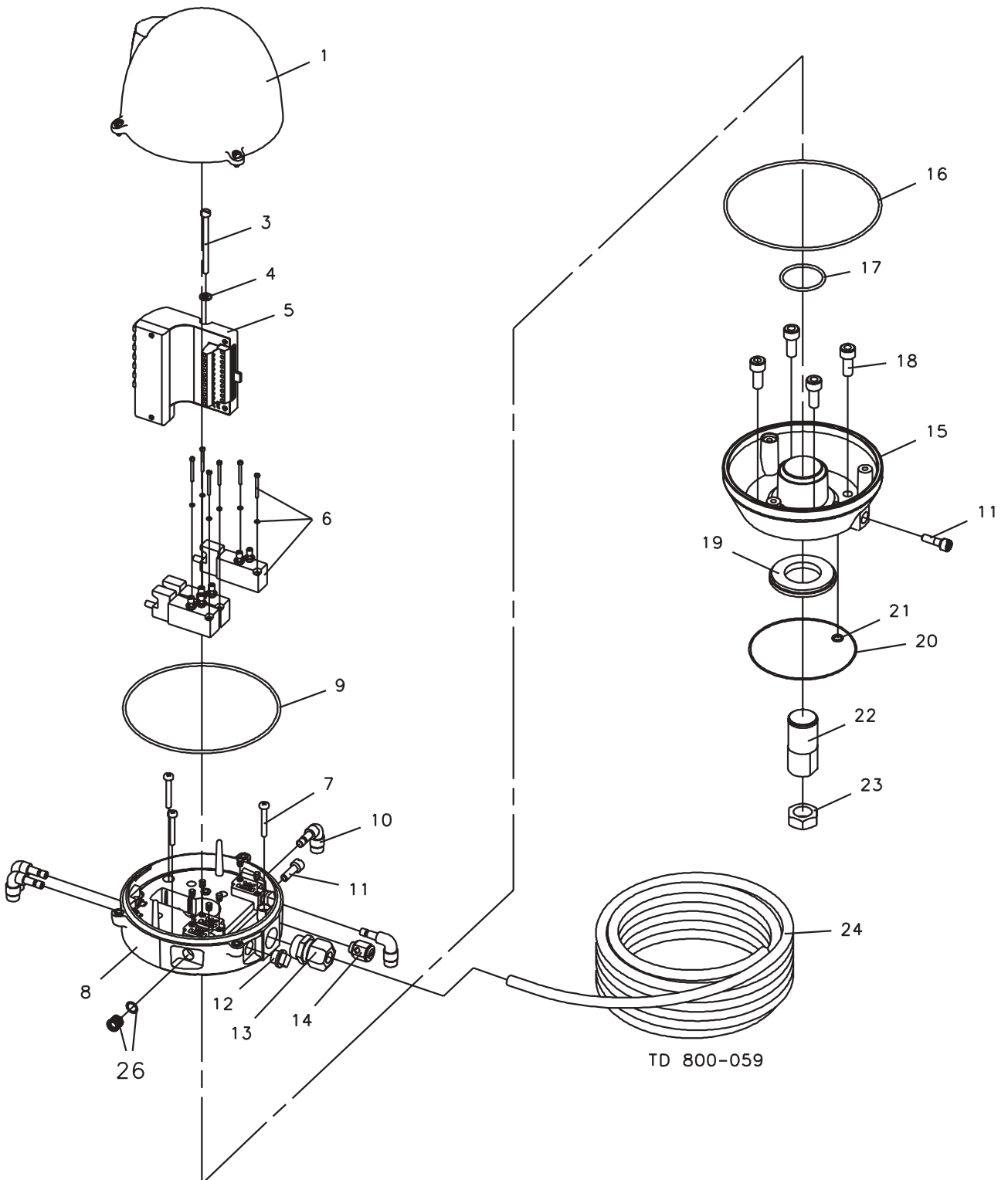

How to contact Alfa Laval

Contact details for all countries are continually updated on our website. Please visit www.alfalaval.com to access the information direct.